

# 2019

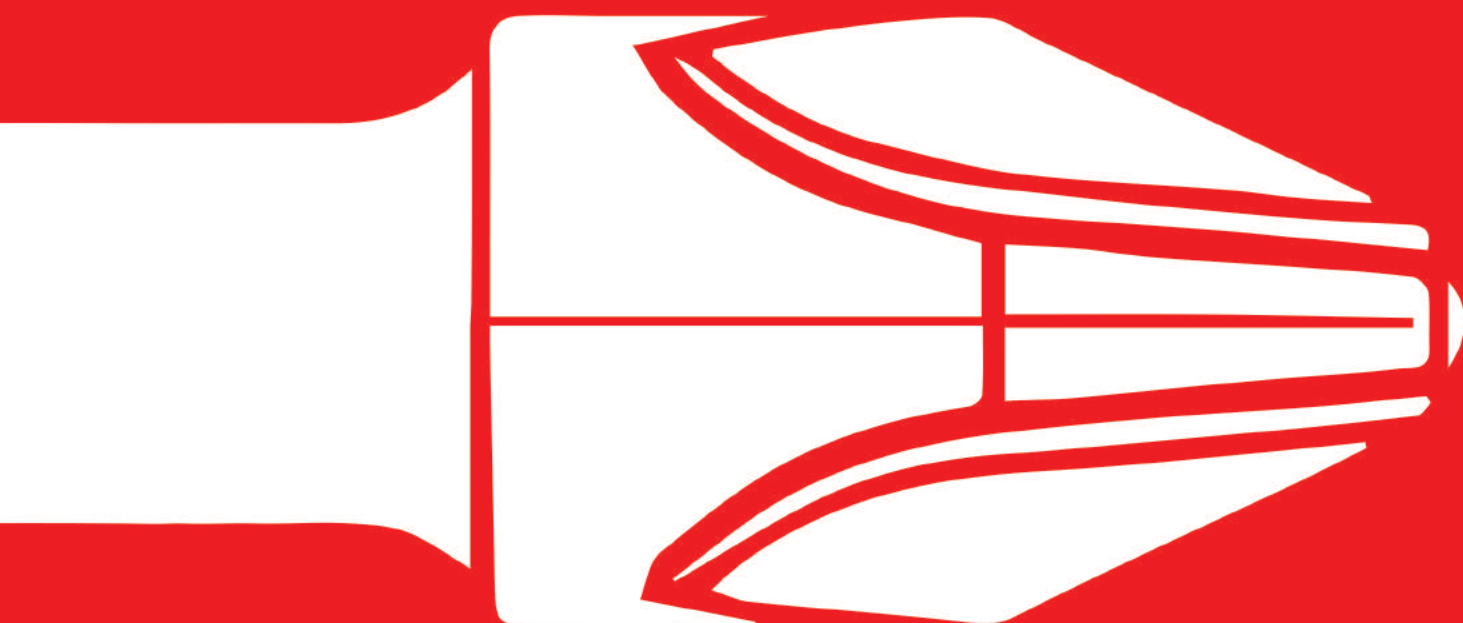

**CATALOGO GENERALE**



**LTI**®

SCREWDRIVING TOOLS





**INSERTI 1/4" E ACCESSORI**  
**1/4" BITS AND ACCESSORIES**  
**EMBOUTS 1/4" ET ACCESSOIRES**  
**PUNTAS DE 1/4" Y ACCESORIOS**

p. 29

1



**LINEE PREMIUM**

**PREMIUM LINES - LIGNES PREMIUM - LÍNEAS PREMIUM**

p. 29

1.1



**LINEE ESSENTIAL**

**ESSENTIAL LINES - LIGNES ESSENTIAL - LÍNEAS ESSENTIAL**

p. 129

1.2

**PORTAINSERTI/ADATTATORI**

**BIT HOLDERS/ADAPTERS - PORTE EMBOUTS/ADAPTATEURS - PORTA PUNTAS/ADAPTADORES**

p. 197

1.3



**INSERTI E CHIAVI SPECIALI**

**SPECIAL BITS AND SETTERS**  
**EMBOUTS ET CLÉS SPÉCIALES**  
**PUNTAS Y LLAVES ESPECIALES**

p. 235

2



**BUSSOLE E ACCESSORI**  
**SOCKETS AND ACCESSORIES**  
**DOUILLES ET ACCESSOIRES**  
**VASOS Y ACCESORIOS**

p. 277

3



**UTENSILI MANUALI**

**HAND TOOLS**  
**OUTILS À MAIN**  
**UTENSILIOS MANUALES**

p. 377

4



**SCHEDE TECNICHE**  
**TECHNICAL DATASHEETS**  
**FICHES TECHNIQUES**  
**FICHAS TÉCNICAS**

p. 451

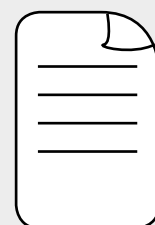

## 1 INSERTI 1/4" E ACCESSORI • 1/4" BITS AND ACCESSORIES • EMBOUTS 1/4" ET ACCESSOIRES • PUNTAS DE 1/4" Y ACCESORIOS

### 1.1 - 1.2 - 1.3

**MAG-Bit+™**



p. 30

**61147**



p. 165

**62036**



p. 204

**COLOUR+**



p. 38

**6606006**



p. 174

**64221030**



p. 212

**MYBIT 7 POWER**



p. 43  
p. 57  
p. 69  
p. 81

**66014004**



p. 179

**62029030**



p. 214

p. 93  
p. 105  
ESS p. 169

**66014006**



p. 180

**65011020**



p. 233

**MYBIT 14**



p. 324

**62015105**



p. 200

**66037010**



p. 233

p. 46  
p. 72  
p. 84  
p. 96  
p. 108  
p. 119  
ESS p. 174

**62016105**



p. 203

## 2 INSERTI E CHIAVI SPECIALI • SPECIAL BITS AND SETTERS • EMBOUTS ET CLÉS SPÉCIALES • PUNTAS Y LLAVES ESPECIALES

**65006200**



p. 246

**65015010**



p. 252

**65015011**



p. 253

## 3 BUSSOLE E ACCESSORI • SOCKETS AND ACCESSORIES • DOUILLES ET ACCESSOIRES • VASOS Y ACCESORIOS

**64230008**

46pcs



p. 358

**64230009**

40pcs



p. 359

**64230013**

26pcs



p. 361

**64230018**

32pcs



p. 363

**64230024**

82pcs



p. 365

**64230030**

108pcs



p. 366

**64230045**

215pcs



p. 367

**64230303**

153pcs



p. 368

**64230304**

179pcs



p. 370

**64230340**

55pcs



p. 372

**64230320**

89pcs



p. 373

**64230322**

82pcs



p. 374

## 4 UTENSILI MANUALI • HAND TOOLS • Outils à main • UTENSILIOS MANUALES

64221001



p. 395

65006047



p. 395

65006050



p. 396

65006055



p. 397

65006042



p. 398

65006041



p. 399

65101



p. 409

65051-52-53



p. 416

65101



p. 418

64230500



p. 430

64230510



p. 431

64230515



p. 432

64230400



p. 433

## GIRAVITI 1000V VDE • 1000V VDE SCREWDRIVERS • TOURNEVIS 1000V VDE • DESTORNILLADORES 1000V VDE

65022



p. 386

65023



p. 386

65024



p. 387

65026



p. 387

65006185



p. 388

65006190



p. 389

65007015

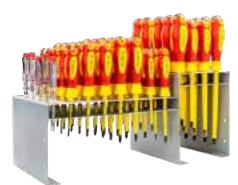

p. 390

## LAMPADE A LED RICARICABILI • RECHARGEABLE LED LAMPS • LAMPES À LED RECHARGEABLES • LÁMPARAS LED RECARGABLES

65981001



p. 435

65981005



p. 436

65981010



p. 437

65981015



p. 438

65981020



p. 439

65981025



p. 440

65981030



p. 441

## CONTENITORI PORTA-UTENSILI • TOOL CONTAINERS • CONTENEURS PORTE-USTENSILES • CONTENEDORES PORTAUTENSILIOS

65991001



p. 443

65991003



p. 443

65991005



p. 444

65991020



p. 444

65991021



p. 445

65991025



p. 445

65991030



p. 446

65991040



p. 446

65991010



p. 447

65991015



p. 447

65991100



p. 448

65991110



p. 449



# INDICE GENERALE

GENERAL INDEX  
TABLE DES MATIÈRES  
ÍNDICE GENERAL

## 1.1

### LINEE PREMIUM PREMIUM LINES LIGNES PREMIUM LÍNEAS PREMIUM

p. 29

**MAG-Bit™**  p. 30

  p. 34

**COLOUR+**  p. 38

  p. 42

 p. 50

**PULSAR®**  p. 55

  p. 56

**TORSION®**  p. 64

  p. 68

**TORSION+**  p. 76

  p. 80

**HDC**  p. 88

  p. 92

**TITANIUM**  p. 100

  p. 104

**INX** 

 p. 112

 p. 116

 p. 117

**ACR®** 

 p. 124

## 1.2

p. 129

### LINEE ESSENTIAL

ESSENTIAL LINES  
LIGNES ESSENTIAL  
LÍNEAS ESSENTIAL

  p. 132

  p. 138

  p. 142

  p. 144

  p. 146

  p. 147

  p. 148

  p. 149

  p. 150

  p. 152

  p. 153

  p. 153

  p. 154

  p. 158

  p. 159

  p. 160

  p. 161

  p. 162

  p. 163

  p. 164

  p. 165

  p. 166

  p. 166

  p. 167

  p. 167

  p. 168

  p. 168

### CHIAVI A BUSSOLA - NUT SETTERS















  p. 188

  p. 193

# 1.3

**p. 197**  
**PORTAINSERI/ADATTATORI**  
 BIT HOLDERS/ADAPTERS  
 PORTE EMBOUTS/ADAPTATEURS  
 PORTA PUNTAS/ADAPTADORES

**PORTAINSERI 1/4" C - BIT HOLDERS**

		p. 199
		 p. 202
		p. 202
		p. 206
		p. 207
		p. 208
		p. 210
		 p. 211
		 p. 211
		 p. 211
		p. 212
		p. 214
		 p. 215
<b>PORTAINSERI 1/4" E - BIT HOLDERS</b>		
		 p. 220

	 p. 220
	p. 221
	 p. 221

**RINVII ANGOLARI - ANGLE DRIVERS**

	  p. 223
---	---

**ADATTATORI - ADAPTERS**

	p. 227
---	--------

**ACCESSORI - ACCESSORIES**



	p. 232
	p. 233

# 2

**p. 235**  
**INSERTI E CHIAVI SPECIALI**  
 SPECIAL BITS AND SETTERS  
 EMBOUTS ET CLÉS SPÉCIALES  
 PUNTAS Y LLAVES ESPECIALES

**INSERTI SPECIALI - SPECIAL BITS**

	p. 238
	p. 241
	p. 242

	p. 244
	p. 247
	p. 249
	p. 251
	p. 254
	p. 256
	p. 257
	p. 258
	p. 259
	p. 260
	p. 261
	p. 262
	p. 263
	p. 264
	p. 264
	p. 265
	p. 265



# INDICE GENERALE

GENERAL INDEX  
TABLE DES MATIÈRES  
ÍNDICE GENERAL

## 3

  p. 266

  p. 267

  p. 268

  p. 268

  p. 269

  p. 269

### CHIAVI SPECIALI - SPECIAL SETTERS

  p. 270

  p. 270

  p. 271

  p. 271

  p. 272

  p. 273

  p. 274

  p. 275

  p. 275

### BUSSOLE E ACCESSORI SOCKETS AND ACCESSORIES DOUILLES ET ACCESSOIRES VASOS Y ACCESORIOS

#### IMPACT

  p. 279

  p. 281

  p. 282

  p. 285

  p. 286

  p. 288

  p. 291

  p. 294

  p. 298

  p. 301

  p. 302

  p. 305

  p. 306

  p. 308

  p. 312

  p. 314

  p. 316

  p. 317

#### CHROME

  p. 321

  p. 322

  p. 323

  p. 325

  p. 326

  p. 329

  p. 330

  p. 331

  p. 332

  p. 333

  p. 336

  p. 339

















	p. 340
	p. 340
	p. 341
	p. 347
	p. 350
	p. 353
	p. 354
	p. 357

# 4

**p. 377**

**UTENSILI MANUALI**  
HAND TOOLS  
OUTILS À MAIN  
UTENSILIOS MANUALES

	p. 378
	p. 384
	p. 386

	p. 387
	p. 392
	p. 393
	p. 394
	p. 398
	p. 400
	p. 401
	p. 402
	p. 420
	p. 424
	p. 426
	p. 428
	p. 429
	p. 429
	p. 430

	p. 434
	p. 442



**p. 451**

**SCHEDE TECNICHE**  
TECHNICAL DATASHEETS  
FICHES TECHNIQUES  
FICHAS TÉCNICAS

**p. 464**

**INDICE PER CODICE**  
**PROGRESSIVO**  
INDEX FOR PROGRESSIVE CODES  
INDEX POUR CODE PROGRESSIF  
ÍNDICE PARA CÓDIGO  
PROGRESIVO



# PROFILO AZIENDALE

COMPANY PROFILE  
PROFIL DE LA SOCIÉTÉ  
PERFIL DE LA COMPANIA



**KRINO**  
GROUP

KRINO è orgogliosa di poter proseguire, con il marchio LTI, una tradizione manifatturiera italiana con oltre 50 anni di esperienza. La storia del marchio ha infatti inizio il 10 Maggio 1961 a Milano, quando Giuseppe Crosa fonda l'azienda. In quel periodo l'industria meccanica italiana conosce un momento di rapida espansione e genera una crescente richiesta di accessori per le operazioni di assemblaggio. L'azienda si specializza nella produzione di inserti per l'avvitatura. LTI si mostra subito capace di fornire prodotti che uniscono, all'elevata precisione, riconosciute caratteristiche di affidabilità e ciò ne permette l'affermazione in ogni settore produttivo: dalle linee di montaggio del settore automobilistico ed elettrodomestico, all'elettronica e fabbricazione di componenti di arredamento. Nel 2011 Krino acquisisce il marchio LTI e trasferisce, nella propria sede di Monticello Brianza, l'officina di produzione con lo stesso personale qualificato, garanzia di qualità del prodotto e del servizio. La crescente richiesta di inserti sempre più performanti, conseguente alla diffusione degli utensili a batteria ad elevate prestazioni in ogni settore del mercato, fino al bricolage, impone la necessità di una continua ricerca di nuovi materiali e soluzioni tecniche in grado di soddisfare al meglio le richieste del mercato. Il nuovo catalogo 2016 LTI è il risultato dei processi innovativi messi in atto da KRINO abbinati alla garanzia di qualità del prodotto che ha da sempre contraddistinto LTI.

*With the LTI brand, KRINO is proud to continue an Italian manufacturing tradition lasting more than 50 years. In fact, Giuseppe Crosa founded LTI on 10 May 1961 in Milan. In those years, the Italian mechanical industry was expanding rapidly, generating a growing demand for equipment and accessories for assembly lines. The company specialised in the production of bits for screwing applications. In no time at all, LTI proved to be capable of supplying products that combined high precision with proven reliability. This allowed it to become successful in every production sector: on the assembly lines of cars and electrical household appliances, in electronics and the manufacturing of decor and furniture items. In 2011, Krino purchased the LTI brand and its experience and moved the production centre to its headquarters in Monticello Brianza, while keeping the LTI qualified personnel as guarantee of the quality of the product and service. The growing demand for more and more efficient bits resulting from the widespread use of high-performance cordless tools in every sector of the market, as well as the increasing popularity of DIY projects, led to the constant search for new materials and technical solutions able to effectively meet the requirements of the market. In this catalogue 2016 LTI, we offer the result of our research and technical innovations.*

*KRINO est fier de poursuivre avec la marque LTI, une tradition de la fabrication italienne avec plus de 50 ans d'expérience. LTI a été créée le 10 mai 1961 à Milan, lorsque Giuseppe Crosa fonda la société. Dans ces années-là, l'industrie mécanique italienne se développe rapidement et génère une demande croissante d'accessoires pour les opérations d'assemblage. L'entreprise se spécialise dans la production d'embouts pour le vissage. LTI se démontre immédiatement en mesure de fournir des produits qui allient la haute précision et les caractéristiques de fiabilité reconnues. Cela lui a permis de s'affirmer dans tous les secteurs de production : sur les chaînes de montage de l'automobile, les petits et grands électroménagers, dans l'électronique et dans la fabrication de composants électroniques. En 2011, Krino rachète la marque LTI et son expérience et transfère dans son propre siège de Monticello Brianza, l'atelier de production, tout en conservant le même personnel qualifié LTI, une garantie de qualité du produit et du service. La demande croissante d'embouts de plus en plus performants, qui dérive de la propagation des outils sans fil à hautes performances, dans tous les secteurs du marché, jusqu'au bricolage, impose la nécessité d'une recherche continue de nouveaux matériaux et de solutions techniques en mesure de satisfaire au mieux les demandes du marché. Dans ce catalogue 2016 LTI, nous offrons le fruit de nos recherches et des innovations techniques de ces dernières années.*

*KRINO esta orgullosa de poder seguir, con la marca LTI, una tradición manufacturera italiana con más de 50 años de experiencia. LTI nace, de hecho, el 10 de mayo del 1961 en Milán, cuando Giuseppe Crosa funda la empresa. En esos años la industria mecánica italiana se expande rápidamente y genera una creciente demanda de accesorios para las operaciones de ensamblaje. La empresa se especializa en la producción de puntas para el atomillado. LTI demuestra enseguida su capacidad de poder suministrar productos que unen a la elevada precisión unas reconocidas características de fiabilidad; esto permite su afirmación en cada sector de la producción: en las cadenas de montaje de automóviles, de los grandes y pequeños electrodomésticos, en la electrónica y en la fabricación de componentes para muebles. En 2011 Krino adquiere la marca LTI y su experiencia, desplazando a su propia sede de Monticello Brianza el taller de producción, manteniendo el mismo personal especializado LTI, garantía de calidad del producto y del servicio. La creciente demanda de puntas con cada vez más un mayor rendimiento (consecuencia de la difusión de los utensilios de batería de grandes rendimientos en cada sector del mercado), hasta el bricolaje, obliga a la empresa a buscar continuamente nuevos materiales y soluciones técnicas capaces de satisfacer lo mejor posible las exigencias del mercado. En el presente catálogo 2016 LTI ofrecemos el fruto de nuestras investigaciones e innovaciones técnicas de estos últimos años.*





# KNOW-HOW

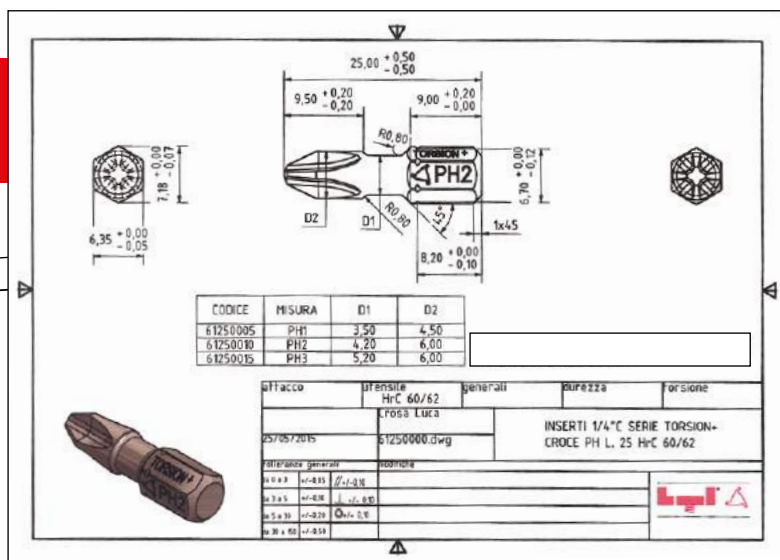

## PROGETTAZIONE E SVILUPPO

DESIGN AND DEVELOP  
LA CONCEPTION ET LE DÉVELOPPEMENT  
DISEÑO Y DESARROLLO

Il nostro ufficio tecnico è in grado progettare l'utensile più indicato alle esigenze dell'utilizzatore industriale e individuare, con l'aiuto del controllo qualità, il materiale ed il trattamento termico più idonei a garantire le migliori performances. Sviluppiamo un nuovo prodotto ogni due giorni.

*Our technical office is able to design the tool best suited to the needs of the industrial user, and to identify, with the help of the quality service, the material and heat treatment best suited to ensure the best performances. We develop a new product every two days.*

*Notre bureau technique est en mesure de concevoir l'outil le plus indiqué aux exigences de l'utilisateur industriel, localiser, avec l'aide du service qualité, le matériau et le traitement thermique les mieux adaptés pour garantir les meilleures performances. Nous développons un nouveau produit tous les deux jours.*

*Nuestra oficina técnica es capaz de diseñar el utensilio más indicado a las exigencias del usuario industrial, detectar, con la ayuda del servicio de calidad, el material y el tratamiento térmico más idóneos para garantizar el mejor rendimiento. Desarrollamos un nuevo producto cada dos días.*

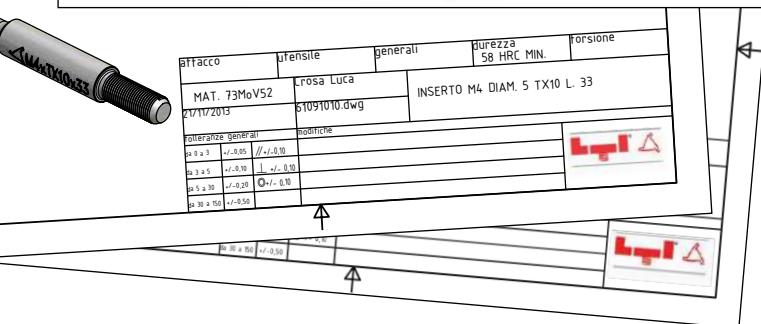

## TORNITURA E PROFILATURA

TURNING AND MILLING  
LE TOURNAGE ET LE PROFILAGE  
TORNEADO Y PERFILADO

Torni a CNC, per operazioni di elevata precisione, con i quali possiamo lavorare barre da diametro 4mm a diametro 20mm. Profilatrici specifiche per inserti. Questo il parco macchine di cui disponiamo per soddisfare le richieste della nostra clientela.

*CNC lathes for high precision machining, which allows machining bars with diameters of 4mm to 20mm. Specific forming machines for bits. We have all the machinery to cater to the needs of our customers.*

*Tours CN pour des usinages à haute précision, avec lesquels nous pouvons travailler des barres de 4mm à 20mm de diamètre. Machines à profiler pour les embouts. C'est le parc machines dont nous disposons pour répondre aux exigences de nos clients.*

*Tornos de CNC para trabajos de gran precisión, con los que podemos trabajar barras de un diámetro que va de 4mm a 20mm. Máquinas para el perfilado específicas para puntas. Este es el parque de máquinas del que disponemos para satisfacer las demandas de nuestros clientes.*

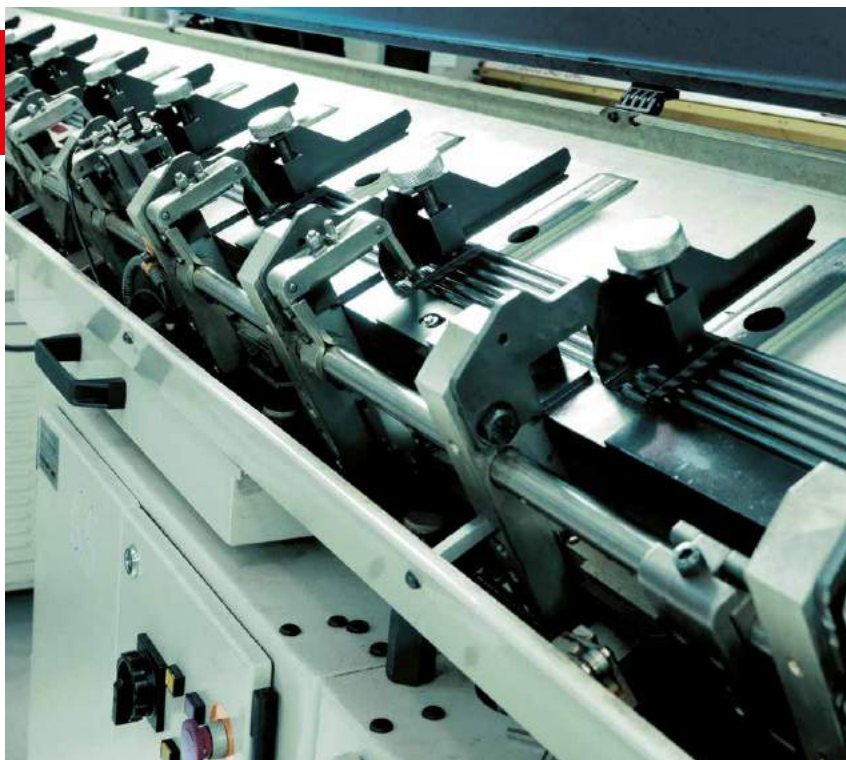

Caricatore automatico di barre per tornio CNC.  
Automatic bar loader for CNC lathe.  
Chargeur automatique de barres pour tour CN.  
Cargador automático de barras para torno CNC.



Controllo microstruttura con microscopio elettronico a 1000X.  
 Structure quality checking by microscope 1000X.  
 Control de qualité sur matériel avec microscope 1000X.  
 Control de calidad de microstruttura con microscopio 1000X.

**TEST DI QUALITÀ**  
 QUALITY TEST  
 TEST DE QUALITÉ  
 PRUEBAS DE CALIDAD

Il modernissimo ed attrezzato laboratorio di controllo qualità garantisce l'intera produzione dei nostri utensili. Specifici ed accurati controlli metallografici sull'acciaio che acquistiamo e sul prodotto che temperiamo assicurano elevate prestazioni dei nostri utensili nella sicurezza più completa.

*The ultra-modern and well-equipped control laboratory guarantees the entire production of our tools. Specific and accurate metallographic controls on the steel that we purchase and on the product that we temper, ensures high performance of our tools in the utmost safety.*

*Notre laboratoire de contrôle de la qualité, très moderne et bien équipé, garantit la totalité de la production de nos outils. Des contrôles métallographiques spécifiques et précis sur l'acier que nous achetons et sur le produit que nous trempions, garantissent des prestations élevées de nos outils dans la sécurité la plus complète.*

*El modernísimo y equipado laboratorio para el control de la calidad garantiza la entera producción de nuestros utensilios. Los específicos y meticulosos controles de metalografía sobre el acero que compramos y sobre el producto que templamos aseguran elevados rendimientos de nuestros utensilios con total seguridad.*

**TRATTAMENTO TERMICO**  
 HEAT TREATMENT  
 LE TRAITEMENT THERMIQUE  
 TRATAMIENTO TÉRMICO

Siamo l'unica azienda in Italia e fra le poche in Europa a trattare internamente i propri inserti con un impianto di tempra sottovuoto. Questo tipo di tecnologia permette con assoluta certezza di evitare problemi di decarburazione ed ossidazione della superficie.

*Internal heat treatment department: the only company in Italy and among the few in Europe to temper bits with a vacuum tempering plant. This type of technology prevents problems associated with oxidation and decarburisation of the surfaces.*

*Le service interne de traitement thermique : unique entreprise en Italie et parmi les rares en Europe à tremper ses propres embouts à l'aide d'une installation de trempe Vacuum. Cette technologie permet, avec une certitude absolue, d'éviter les problèmes de décarburation et d'oxydation de la surface.*

*Departamento interno para el tratamiento térmico: única empresa en Italia y una de las pocas en Europa que temple sus propias puntas con una planta de templado Vacuum. Este tipo de tecnología permite evitar problemas de decarburación y oxidación de la superficie con absoluta certeza.*



Forno di tempra sottovuoto per trattamento termico.  
 Vacuum furnace for heat treatment.  
 Installation de trempe Vacuum pour traitement thermique.  
 Planta de templado Vacuum para tratamiento térmico.



## ARTICOLI SU RICHIESTA

CUSTOME-MADE ITEMS  
ARTICLES SUR DEMAND  
ARTICUOLS À PEDIDO

La nostra azienda produce inserti per avvitatori secondo gli standard internazionali ma realizza anche prodotti su richiesta specifica e disegno del cliente anche per lotti di ridotta quantità. L'esperienza di cui dispongono i nostri tecnici è di supporto per la progettazione e la soluzione di ogni particolare necessità legate ad operazioni di avvitatura su impianti automatici.

Tutte le lavorazioni meccaniche ed il trattamento termico vengono eseguiti al nostro interno; per questo motivo garantiamo al nostro cliente massima flessibilità, un servizio custom fit ai massimi livelli per la realizzazione di prodotti di elevata qualità e specificità. Operiamo con successo nell'industria dei grandi elettrodomestici, delle catene di montaggio meccaniche, nei cantieri navali o aerospaziali; i nostri prodotti ogni giorno incontrano sfide importanti ed i nostri clienti riconoscono il supporto costante e qualificato che offriamo loro.

*Our company manufactures bits for drills and drivers in accordance with the international standards, as well as products to fit the exact specifications and requests of customers, including small quantities. The experience and expertise of our technicians supports the design and solution of each detail of automatic screwing operations.*

*The machining operations and heat treatments are all performed internally; for this reason, we are able to offer customers maximum flexibility, first-rate personalised service to create high quality and specific products. We work successfully in the field of household appliances, mechanical assembly lines, shipbuilding and aircraft production. Our products face important challenges every day and our customers recognise the constant and qualified support we offer them.*

*Notre société fabrique des embouts pour visseuses conformément aux normes internationales, mais elle fabrique également des produits sur demande spécifique et sur dessin du client, même pour de petits lots. L'expérience de nos techniciens apporte une aide à la conception et à la solution de tout besoin particulier lié aux opérations de vissage sur des installations automatiques. Tous les usinages mécaniques et les traitements thermiques sont effectués en interne. C'est pour cette raison que nous garantissons à nos clients une polyvalence maximale, un service personnalisé au plus haut niveau pour la réalisation de produits hautement qualitatifs et spécifiques. Nous travaillons avec succès dans l'industrie des gros appareils électroménagers, des lignes d'assemblage mécaniques, dans la construction navale ou aérospatiale. Nos produits répondent aux défis quotidiens et nos clients sont satisfaits du support constant et qualifié que nous leur offrons.*

*Nuestra empresa produce portapuntas para atornilladores siguiendo los estándares internacionales, pero también realiza productos bajo petición específica y diseño del cliente incluso para lotes pequeños. La experiencia de la que disponen nuestros técnicos sirve como ayuda para proyectar y solucionar cualquier particular necesidad ligada a operaciones de atornillado en sistemas automáticos.*

*Todos los trabajos mecánicos y el tratamiento térmico son realizados por nosotros; por este motivo garantizamos a nuestro cliente la máxima flexibilidad, un servicio excelente a la medida del cliente para realizar productos específicos y de elevada calidad. Operamos con éxito en la industria de los grandes electrodomésticos, de las cadenas de montaje mecánicas, en los astilleros o en los talleres aeroespaciales. Nuestros productos cada día se enfrentan a importantes desafíos y nuestros clientes reconocen el apoyo constante y especializado que les ofrecemos.*



*Esempi di articoli realizzati su richiesta.  
Examples of items made on demand.  
Exemples des articles réalisés sur demand.  
Exemplos de articulos realizados a pedido.*



*Vista di un tornio a controllo numerico di elevata precisione nell'officina LTI.*

*View of a high precision CNC lathe in the LTI workshop.*

*Vue d'un tour à commande numérique haute précision dans l'atelier LTI.*

*Vista de un torno CNC de alta precisión en el taller LTI.*



## ARTICOLI SU RICHIESTA

CUSTOME-MADE ITEMS  
ARTICLES SUR DEMAND  
ARTICUOLS À PEDIDO



Per raggiungere l'eccellenza nel servizio alla clientela offriamo oggi la possibilità di realizzare set e valigette con contenuti specifici: il nostro parco macchine si è infatti ampliato con una fresatrice taglia spugne che consente la realizzazione di sedi dedicate per l'inserimento di utensili e accessori su esigenza del cliente.

*To achieve excellence in customer service we can offer you to create sets and cases with specific contents: our machine fleet has in fact been expanded with a sponge milling machine that allows the creation of dedicated seats for the insertion of tools and accessories on customer's request.*

*Pour atteindre l'excellence du service à la clientèle, nous offrons maintenant la possibilité de créer des ensembles et des boîtiers avec des contenus spécifiques: notre parc de machines a en effet été élargi avec une fraiseuse à éponger qui permet la création de sièges dédiés pour l'insertion d'outils et d'accessoires à la demande du client.*

*Para alcanzar la excelencia en el servicio al cliente, ahora ofrecemos la posibilidad de crear conjuntos y cajas con contenidos específicos: nuestra flota de máquinas se ha ampliado con una fresadora de esponja que permite la creación de asientos dedicados para la inserción de herramientas y accesorios a petición del cliente.*

Il cliente può personalizzare il contenuto del set scegliendo gli utensili desiderati e decidendo il colore della spugna nella quale saranno disposti.

*The customer can customize the contents of the set by choosing the desired tools and deciding the color of the sponge in which they will be arranged.*

*Le client peut personnaliser le contenu de l'ensemble en choisissant les outils souhaités et en choisissant la couleur de l'éponge dans laquelle ils seront disposés.*

*El cliente puede personalizar el contenido del conjunto seleccionando las herramientas deseadas y decidiendo el color de la esponja en la que se colocarán.*







[blog.krino.it](http://blog.krino.it)

Ancora non conosci Mr. K?! Cercalo anche sul blog!

Blog.Krino.It

Mr. K è il nuovo paladino della ferramenta che ogni mese ci regala preziosi video con consigli e informazioni utili sui nostri prodotti!

*You still do not know Mr. K ?! Look for it on the blog too!*

*Blog.Krino.It*

*Mr. K is the new hardware champion who every month gives us precious videos with tips and useful information about our products!*

*Vous ne connaissez toujours pas M. K?! Cherchez aussi sur le blog!*

*Blog.Krino.It*

*M. K est le nouveau champion du matériel informatique qui, chaque mois, nous fournit de précieuses vidéos contenant des conseils et des informations Utiles sur nos produits!*

*¿Aún no conoces al Sr. K? ¡Búscalo en el blog también!*

*Blog.Krino.It*

*¡El Sr. K es el nuevo campeón de hardware que cada mes nos brinda videos valiosos con consejos e información útil sobre nuestros productos!*

LTI è presente anche sui social con tutorial, presentazioni di prodotto e tante altre idee, dimostrazione di un'azienda dinamica e al passo coi tempi che non si accontenta dei soliti standard comunicativi.

*LTI is also present on social media with tutorials, product presentations and many other ideas, demonstration of a dynamic company that isn't satisfied with the usual communication standards.*

*LTI est également présent sur les médias sociaux avec des tutoriels, des présentations de produits et de nombreuses autres idées, la démonstration d'une entreprise dynamique et en phase avec l'époque qui n'est pas satisfaite des standards de communication habituels.*

*LTI también está presente en las redes sociales con tutoriales, presentaciones de productos y muchas otras ideas, demostraciones de una empresa dinámica y en sintonía con los tiempos que no están satisfechos con los estándares de comunicación habituales.*



**TiFaForare**

**@KrinoTools**





# COME LEGGERE IL CATALOGO

HOW TO USE THE CATALOGUE  
COMMENT LIRE LE CATALOGUE  
CÓMO LEER EL CATÁLOGO

Argomento specifico  
Specific topic  
Argument spécifique  
Tema específico

Indicazioni del capitolo  
Chapter indications  
Indications du chapitre  
Indicaciones del capítulo

Specifiche di prodotto  
Product specifications  
Spécificités du produit  
Especificaciones del producto

Indicazioni della famiglia prodotto  
Indications of the product family  
Indications de la famille de produits  
Indicaciones sobre la familia del producto

Confezionamento base  
Basic packaging  
Emballage de base  
Embalaje base

Altri confezionamenti  
Other packaging  
Autres emballages  
Otros tipos de Embalaje



Descrizione del prodotto  
 Product description  
 Description du produit  
 Descripción del producto

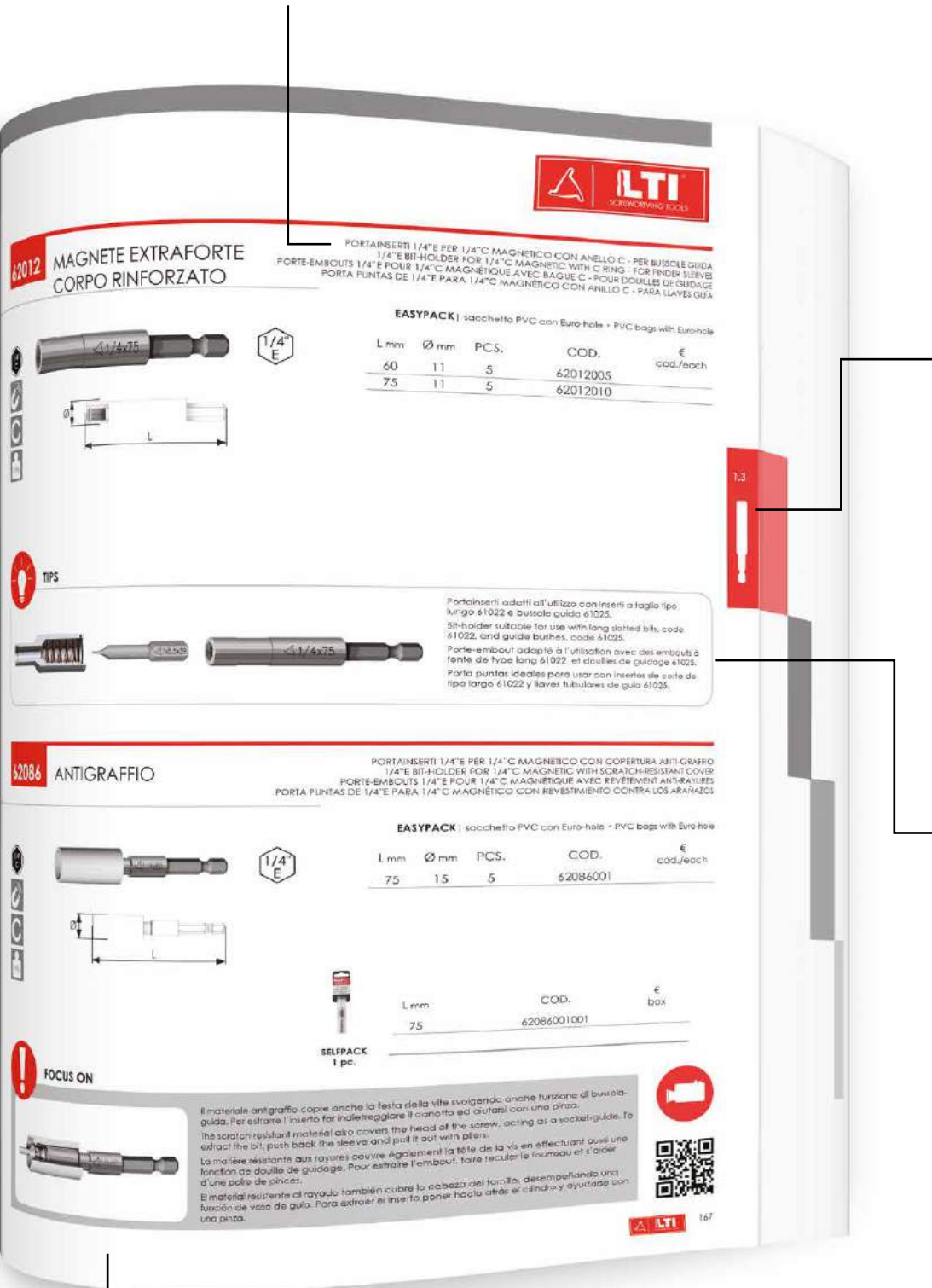

Indicazioni del capitolo  
 Chapter indications  
 Indications du chapitre  
 Indicaciones del capítulo

Approfondimenti  
 In-depth studies  
 Approfondissements  
 Más noticias

Approfondimenti  
 In-depth studies  
 Approfondissements  
 Más noticias



# COME LEGGERE IL CATALOGO

HOW TO USE THE CATALOGUE  
COMMENT LIRE LE CATALOGUE  
CÓMO LEER EL CATÁLOGO

## 1 62013 MAGNETICI SENZA ANELLO 2

3 PORTAINSERTI 1/4"E PER 1/4"C MAGNETICO  
1/4"E BIT-HOLDER FOR 1/4"C MAGNETIC  
PORTE-EMBOUTS 1/4"E POUR 1/4"C MAGNÉTIQUE  
PORTA PUNTAS DE 1/4"E PARA 1/4"C MAGNÉTICO

4 40/44 HRC

10 EASYPACK | sacchetto PVC con Euro-hole • PVC bags with Euro-hole

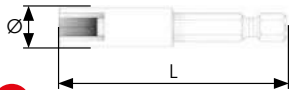

9

11	12	13	14
L mm	Ø mm	PCS.	COD.
50	10	5	62013004
60	10	5	62013005
75	10	5	62013010
100	10	5	62013015
120	10	5	62013020
150	10	5	62013025
200	10	5	62013030
250	10	5	62013035

€  
cad./each



SELFPACK  
1 pc.

11	13	16
L mm	COD.	€ box
50	62013004001	
60	62013005001	
75	62013010001	
100	62013015001	

1 Indicazione della famiglia prodotto  
Indication of the product family  
Indication de la famille de produits  
Indicación sobre la familia del producto

2 Prodotto presentato  
Product presented  
Produit présenté  
Producto presentado

3 Descrizione del prodotto  
Product description  
Description du produit  
Descripción del producto

4 Caratteristiche tecniche  
Technical features  
Spécifications techniques  
Características técnicas

5 Impronta/innesto  
Tip/connection  
Empreinte/queue  
Huella/empalme

6 Immagine del prodotto  
Product image  
Image du produit  
Imagen del producto

7 Attacco  
Attachment  
Queue  
Empalme

8 Specifiche di prodotto  
Product specifications  
Spécificités du produit  
Especificaciones del producto

9 Disegno tecnico  
Technical design  
Dessin technique  
Dibujo técnico

10 Confezionamento base  
Basic packaging  
Emballage de base  
Embalaje base

11 Misure specifiche  
Specific measurements  
Mesures spécifiques  
Medidas específicas

12 Quantità minima d'acquisto  
Minimum amount of purchase  
Quantité minimum d'achat  
Cantidad mínima de compra

13 Codice prodotto  
Product Code  
Code produit  
Código producto

14 Prezzo unitario  
Unit price  
Prix à l'unité  
Precio unitario

15 Altri confezionamenti  
Other packaging  
Autres emballages  
Otros tipos de embalaje

16 Prezzo per confezione  
Price per pack  
Prix par boîte  
Precio por confección

# CONFEZIONAMENTO

PACKAGING  
CONDITIONNEMENT  
EMBALAJE



5 - 10 pcs.



## EASYPACK

- |   |   |
|---|---|
| 1. Sacchetto PVC termosaldato con asola Euro-hole | 1. Sachet PVC thermoscellé avec trou de suspension européen |
| 2. Confezionamento in box di cartone              | 2. Conditionnement en boîtes en carton                      |
| 1. Heat-sealed PVC bag with Euro-hole             | 1. Bolsa de PVC soldado térmicamente con ojal Euro-hole     |
| 2. In cardboard box packaging                     | 2. Embalaje con caja de cartón                              |

1 - 2 pcs.



## SELPACK

- |  |   |
|--|---|
| 1. Tubo PP con tappo con asola Euro-hole   | 1. Tube PP avec bouchon et trou de suspension européen  |
| 2. Clip PP appendibile con asola Euro-hole | 2. Clip PP à suspendre avec trou de suspension européen |
| 1. PP tube with cap with Euro-hole         | 1. Tubo PP con tapón con ojal Euro-hole                 |
| 2. Hangable PP clip with Euro-hole         | 2. Cierre PP que se puede colgar con ojal Euro-hole     |

5 - 10 pcs.



## MINIBOX

- |  |  |
|--|--|
| - Scatoletta PP richiudibile con asola Euro-hole | - Boîte PP refermable avec trou de suspension européen |
| - Resealable PP box with Euro-hole               | - Cajita PP que se puede cerrar con ojal Euro-hole     |

# APPROFONDIMENTI

IN-DEPTH STUDIES  
APPROFONDISSEMENTS  
MÁS NOTICIAS

## LAB TEST



Archivio multimediale creato in collaborazione con il laboratorio di analisi e controllo qualità: progettazione e realizzazione, test comparativi e applicazioni pratiche.

Archives multimédia créées en collaboration avec le laboratoire d'analyse et de contrôle de la qualité : conception et réalisation, essais comparatifs et applications pratiques.



Multimedia archive created in collaboration with the analysis and quality control laboratory: design and creation, comparative tests and practical applications.

Archivo multimedial creado en colaboración con el laboratorio de análisis y control de la calidad: diseño y realización, pruebas de comparación y aplicaciones prácticas.



### FOCUS ON

Approfondimenti specifici per prodotto: caratteristiche, indicazioni tecniche e curiosità.

Approfondissements spécifiques par produit : indications techniques et curiosités.

Specific studies for product characteristics, technical specifications and peculiarities.

Enfoques específicos para el producto: características, indicaciones técnicas y curiosidades.



### TIPS

Consigli di utilizzo e suggerimenti per usufruire al meglio dei nostri prodotti, alle condizioni più vantaggiose.

Conseils d'utilisation et idées pour tirer le meilleur parti de nos produits, aux conditions les plus avantageuses.

Tips and suggestions on how to best use our products, in the most favourable conditions.

Consejos de uso y sugerencias para usar lo mejor posible nuestros productos en las condiciones más ventajosas.



**ATTACCHI FEMMINA**  
FEMALE DRIVES - QUEUE FEMME - HEMBRA EMPALME



	<b>QUADRO</b> SQUARE • CARRÉ • CUADRADO
	<b>4mm C</b>
	<b>1/4" C</b>
	<b>1/4" E</b>
	<b>1/4"</b>
	<b>5/16" C</b>
	<b>5/16"</b>
	<b>7/16" E</b>
	<b>3/8" 10mm</b>
	<b>1/4"</b>
	<b>3/8"</b>
	<b>1/2"</b>
	<b>5/8"</b>
	<b>3/4"</b>
	<b>1"</b>
	<b>1-1/2"</b>



**SIMBOLI**  
SYMBOLS - SYMBOLES - SÍMBOLOS

	<b>MAGNETICO</b> MAGNETIC • À AIMANTS • MAGNÉTICOS
	<b>NON MAGNETICO</b> NON-MAGNETIC • SANS AIMANT • NO MAGNÉTICOS
	<b>TRATTENIMENTO MAGNETICO DELLA VITE</b> SCREW-BLOCKING MAGNET • BLOCAGE MAGNETIQUE DE VIS • BLOQUEO MAGNÉTICO DEL TORNILLO
	<b>TRATTENIMENTO MAGNETICO DELL'INSERTO</b> BIT-BLOCKING MAGNET • BLOCAGE MAGNETIQUE DE EMBOUT • BLOQUEO MAGNÉTICO DE LA PUNTA
	<b>CON MANDRINO DI BLOCCO</b> WITH LOCK CHUCK • AVEC MANDRIN DE BLOCAGE • CON MANDRIL DE BLOQUEO
	<b>SGANCIO RAPIDO</b> QUICK RELEASE • DÉCLENCHEMENT RAPIDE • DESENGANCHE RÁPIDO
	<b>CON SFERA</b> WITH BALL • AVEC BILLE • CON ESFERA
	<b>CON ANELLO C</b> WITH C RING • AVEC BAGUE C • CON ANILLO C
	<b>TRATTENIMENTO</b> HOLDING FORCE • FORCE DE MAINTIEN • FUERZA DE RETENCIÓN
	<b>NUMERO DI DENTI</b> NUMBER OF THEET • NOMBRE DE DENTS • NÚMERO DE DIENTES
	<b>MAGNETE RETRAIBILE</b> RETRACTABLE MAGNET • MAGNET RÉTRACTILE • IMÁN RETRACTIL
	<b>TESTA SFERICA</b> BALL-HEAD • TÊTE SPHÉRIQUE • CABEZA ESFÉRICA
	<b>UTENSILE MANUALE</b> HAND TOOL • OUTIL A MAIN • UTENSILIO MANUAL
	<b>UTENSILE PER MACCHINA</b> POWER TOOL • OUTIL MACHINE • UTENSILIO A MAQUINA

**ATTACCHI MASCHIO**  
MALE DRIVES - QUEUE MALE - MACHO EMPALME

	<b>7mm</b>
	<b>SPINA PASSANTE</b> THROUGH HOLE • TRAVERSANTES • AGUJERO PASANTE
	<b>BSF 3/16x32</b>
	<b>1/4" C</b>
	<b>UNF 10x32</b>
	<b>M3</b>
	<b>M4</b>
	<b>M5</b>
	<b>M6</b>
	<b>FILETTATO</b> THREADED • FILETE • ROSCADO
	<b>ESAGONO</b> HEXAGON • TÊTE HEXAGONALE • HEXÁGONO
	<b>3mm</b>
	<b>5,5mm</b>
	<b>5/16" C</b>
	<b>5/16"</b>
	<b>7/16" E</b>
	<b>3/8" 10mm</b>
	<b>4mm C</b>
	<b>1/4"</b>
	<b>3/8"</b>
	<b>1/2"</b>
	<b>5/8"</b>
	<b>3/4"</b>
	<b>1"</b>
	<b>1-1/2"</b>

	<b>VITE AUTOFILETTANTE PER LEGNO</b> SELF-TAPPING SCREW FOR WOOD • VIS AUTOTARAUEUSES POUR BOIS • TORNILLOS DE ROSCA CHAPA PARA MADERA
	<b>VITE AUTOFILETTANTE PER METALLO</b> SELF-TAPPING SCREWS FOR METAL • VIS AUTOTARAUEUSES POUR MÉTAL • TORNILLOS DE ROSCA CHAPA PARA METAL
	<b>VITE AUTO-FORANTE</b> SELF-DRILLING SCREWS • VIS AUTO-PERÇEUSES • TORNILLOS AUTOTALADRANTES

	<b>A</b> <b>PERNO</b> PIN • GOUPILLE • PERNO
	<b>B</b> <b>SFERA</b> BALL • BILLE • ESFERA
	<b>C</b> <b>FORO</b> HOLE • TROU • ORIFICIO



# GUIDA ALLA SCELTA - INSERTI E CHIAVI













































GUIDE TO CHOOSING THE MOST SUITABLE PRODUCT - BITS AND SETTERS

GUIDE POUR LE CHOIX - EMBOUTS ET CLÉS

GUÍA A LA ELECCIÓN - PUNTAS Y LLAVES

	p. 31	p. 39	p. 51	p. 65	p. 77	p. 89	p. 101	p. 113	p. 125	p. 132			
	p. 32	p. 40	p. 52	p. 66	p. 78	p. 90	p. 102	p. 113	p. 126	p. 138			
	p. 33	p. 41	p. 53	p. 67	p. 79	p. 91	p. 103	p. 114		p. 142			
										p. 144			
										p. 146			
										p. 147			
										p. 149			
										p. 149			
			p. 54					p. 114		p. 150			
										p. 152			
										p. 153			
										p. 153			
						p. 91	p. 103	p. 115		p. 154			
										p. 158			
										p. 159			
										p. 160			
										p. 161			
										p. 162			
										p. 163			
										p. 164			
										p. 165			
												p. 166	
												p. 166	
												p. 167	
												p. 167	
													p. 188



													
		p. 244	p. 249	p. 256	p. 258	p. 260	p. 262	p. 264	p. 268		p. 266		
		p. 244		p. 256	p. 258	p. 260	p. 262	p. 264		p. 268	p. 266		
	p. 239	p. 246	p. 249	p. 256	p. 259	p. 260	p. 262						
	p. 239				p. 258								
													
													
													
													
	p. 238	p. 245	p. 249								p. 266	p. 266	
													
													
													
													
		p. 245	p. 250										
													
													
													
													
													
													
													
	p. 238												
													
	p. 240												
	p. 240												
			p. 250										
													p. 269
													p. 269
													
													
													



**VEDI P. 127**  
**SEE P. 127**  
**VOIR P. 127**  
**VÉASE P. 127**

COME SCEGLIERE L'INSERTO PREMIUM  
 HOW TO CHOOSE THE RIGHT PREMIUM BIT  
 COMMENT CHOISIR L'EMBOUIT PREMIUM  
 CÓMO ESCOGER LA PUNTA PREMIUM



**Durezza**  
 Hardness  
 Dureté  
 Dureza



**Tenacità**  
 Tough  
 Robuste  
 Resistente



**Elasticità**  
 Elasticity  
 Élasticité  
 Elasticidad



**Utilizzo**  
 Use  
 Utilisation  
 Uso



**Acciaio e finitura**  
 Steel and surface finish  
 Acier et finition de surface  
 Acero y acabado superficial



**Speciale per**  
 Special for  
 Spéciale par  
 Especial por



**Utilizzi generali**  
 General uses  
 Utilisations générales  
 Usos generales



**A mano**  
 By hand  
 À la main  
 A mano



**Acciaio S2**  
 S2 steel  
 Acier S2  
 Acero S2



**Acciaio S3**  
 S3 steel  
 Acier S3  
 Acero S3



**Acciaio INOX**  
 Stainless steel  
 Acier inoxydable  
 Acero inoxidable



**Fosfatazione allo zinco**  
 Zinc phosphates  
 Phosphates de zinc  
 Fosfatado de zinc



**Fosfatazione al manganese**  
 Manganese phosphates  
 Phosphates de manganèse  
 Fosfatado de manganese



**Rivestimento ambrato**  
 Amber coated  
 Revêtement ambré  
 Revestimiento de ámbar



**Rivestimento bluettato anti-usura**  
 Anti-wear blued coated  
 Revêtement bleui anti-usure  
 Revestimiento azulado antidesgaste



**Rivestimento al Nitruro di Titanio**  
 Titanium Nitride coated  
 Revêtement de nitrure de titane  
 Revestimiento de nitruro de titanio



**Rivestimento in polvere di diamante**  
 Diamond powder coated  
 Revêtue de poudre de diamant  
 Revestida con polvo de diamante



**Con avvitatori a impuls**  
 Impact and pulse wrenches  
 Visseuses à impulsions  
 Atomilladores de impacto



**Utilizzi intensivi**  
 Intensive use  
 Usages intensifs  
 Usos intensivos



**Maggior vita dell'utensile**  
 Longer tool life  
 Durée de vie plus longue  
 Vida útil más larga



**Riconoscimento visivo**  
 Visual recognition  
 Reconnaissance visuelle  
 Reconocimiento visual



**Trattenimento magnetico**  
 Magnetic retention  
 Rétenion magnétique  
 Retención magnético



**Per viti usurate**  
 Worn screws  
 Vis usées  
 Tornillos desgastados



**Grip**  
 Grip  
 Adhérence  
 Agarre



**Utilizzi in ambienti marini**  
 Use in marine environments  
 Utilisation en milieu marin  
 Uso en ambientes marinos



**Per viti INOX**  
 For stainless steel screws  
 Pur vis en acier inoxydable  
 Para tornillos de acero inoxidable

# GUIDA AGLI INSERTI PREMIUM

GUIDE TO PREMIUM BITS  
GUIDE POUR LE EMBOUTS PREMIUM  
GUÍA A LA PUNTAS PREMIUM

CHOOSE YOUR BIT	HRC						
<b>PULSAR®</b> <b>TOP</b>	★★★☆☆	★★★★★	★★★★★	★★★★★		S3 $Mn + PO_4$ <b>impact</b>	p. 50
<b>TORSION+</b> <b>TOP</b>	★★★★★	★★★★★	★★★★★	★★★★★		S3	p. 76
<b>TORSION®</b> <b>TOP</b>	★★☆☆☆	★★★☆☆	★★★☆☆	★★★☆☆		S2	p. 64
<b>MAG-Bit+™</b> <b>SPECIAL</b>	★★★☆☆	★★★☆☆	★★★☆☆	★★★☆☆		S2 $Zn + PO_4$	p. 30
<b>TITANIUM</b> <b>SPECIAL</b>	★★★★★	★★☆☆☆	★★☆☆☆	★★☆☆☆		S2	p. 100
<b>HDC</b> <b>SPECIAL</b>	★★★☆☆	★★☆☆☆	★★☆☆☆	★★☆☆☆		S2	p. 88
<b>ACR®</b> <b>BASIC</b>	★★★☆☆	★★☆☆☆	★★☆☆☆	★★☆☆☆		S2 $Zn + PO_4$	p. 124
<b>INX</b> <b>BASIC</b>	★★☆☆☆	★★☆☆☆	★★☆☆☆	★★☆☆☆		Inox	INOX p. 112
<b>COLOUR+</b> <b>BASIC</b>	★★★☆☆	★★☆☆☆	★★★☆☆	★★☆☆☆		S2 $Zn + PO_4$	p. 38
<b>ESSENTIAL</b> <b>BASIC</b>	★★★☆☆	★★☆☆☆	★★☆☆☆	★★☆☆☆		S2 $Zn + PO_4$	p. 129



*Nel campo dell'avvitatura, applicazioni sempre più specifiche e avvitatori a batteria sempre più potenti richiedono utensili con caratteristiche adeguate a ciascuna particolare situazione ed in grado di garantire performances sempre più elevate. Le linee PREMIUM che presentiamo in questa prima sezione, sono il frutto dell'evoluzione di questi ultimi anni di lavoro in KRINO, dove l'esperienza e la conoscenza che contraddistinguono il marchio LTI, sono state valorizzate e sviluppate dai nostri ingegneri per offrire una gamma di prodotti all'altezza delle aspettative.*

*Increasingly more specific applications and powerful battery-operated drivers require the use of tools with the appropriate characteristics, able to guarantee the highest performances at all times. The PREMIUM lines featured in this first section come from the evolution over the years and KRINO's constant commitment to research. Our engineers have capitalised and built on the long experience and knowledge characterising the history of LTI to offer new innovative product lines for numerous projects and applications.*

*Les applications toujours plus spécifiques et les visseuses sans fil toujours plus puissantes nécessitent des outils aux caractéristiques appropriées, en mesure de garantir des performances toujours plus élevées. Les lignes PREMIUM que nous présentons dans cette première partie sont le fruit de l'évolution de ces dernières années et de l'engagement continu de KRINO dans la recherche. Pendant ces années, l'expérience et la connaissance qui distinguent l'histoire de LTI, ont été valorisées par nos ingénieurs, en offrant de nouvelles lignes de produits de pointe dans la conception et les applications.*

*Las aplicaciones cada vez más específicas y los atornilladores de batería cada vez más potentes necesitan emplear utensilios con características adecuadas que puedan garantizar rendimientos cada vez más elevados. Las líneas PREMIUM que presentamos en esta primera sección son el resultado de la evolución de estos últimos años y de la constante inversión por parte de KRINO en la investigación técnica. Años en donde la experiencia y el conocimiento que marcan la historia de LTI han sido valorizados por nuestros ingenieros para poder ofrecer nuevas líneas de productos a la vanguardia para el diseño y las aplicaciones.*



# 1.1

## LINEE PREMIUM PREMIUM LINES LIGNES PREMIUM LÍNEAS PREMIUM



### MAG-Bit+™

INSERTI 1/4" CON SISTEMA DI TRATTENIMENTO MAGNETICO  
1/4" BITS WITH MAGNETIC RETENTION SYSTEM • EMBOUTS 1/4" AVEC BAGUE DE RÉTENTION  
MAGNÉTIQUE • PUNTAS DE 1/4" CON SISTEMA DE RETENCIÓN MAGNÉTICO

p. 30



### COLOUR+

INSERTI 1/4" CON ANELLO COLORATO  
1/4" COLORED RING BITS • EMBOUTS 1/4" AVEC BAGUE DE COULEUR • PUNTAS DE 1/4" CON ANILLO  
DE COLOR

p. 38



### PULSAR®

INSERTI 1/4" PER AVVITATORI A MASSA BATTENTE  
1/4" BITS FOR IMPACT WRENCHES • EMBOUTS 1/4" POUR VISSEUSES À MASSE BATTANTE • PUNTAS DE  
1/4" PARA ATORNILLADORES DE IMPACTO

p. 50



### TORSION®

INSERTI 1/4" TENACI RESISTENTI A COPPIE ELEVATE  
1/4" HEAVY DUTY BITS, HIGH TORQUES RESISTANT • EMBOUTS 1/4" TENACES ET RÉSISTANTS AUX  
COUPLES ÉLEVÉS • PUNTAS DE 1/4" TENACES, RESISTENTES A ELEVADAS PAR DE TORSIÓN

p. 64



### TORSION+

INSERTI EXTRA HARD 1/4" RESISTENTI A COPPIE ELEVATE  
1/4" EXTRA-HARD BITS TORQUES RESISTANT • EMBOUTS 1/4" EXTRA HARD RÉSISTANTS AUX COUPLES  
ÉLEVÉS • PUNTAS DE 1/4" EXTRA HARD RESISTENTES A ELEVADAS PAR DE TORSIÓN

p. 76



### HDC

INSERTI 1/4" CON RIVESTIMENTO AL DIAMANTE  
1/4" BITS WITH DIAMOND COATING • EMBOUTS 1/4" AVEC REVÊTEMENT DIAMANT • PUNTAS DE 1/4"  
CON RECUBRIMIENTO DE DIAMANTE

p. 88



### TITANIUM

INSERTI 1/4" CON RIVESTIMENTO AL NITRURO DI TITANIO  
1/4" BITS WITH TITANIUM NITRIDE COATING • EMBOUTS 1/4" AVEC REVÊTEMENT NITRURE DE TITANE •  
PUNTAS DE 1/4" CON RECUBRIMIENTO DE NITRURO DE TITANIO

p. 100



### INX

INSERTI 1/4" REALIZZATI IN ACCIAIO INOX  
1/4" STAINLESS STEEL BITS • EMBOUTS 1/4" RÉALISÉS EN ACIER INOXYDABLE • PUNTAS DE 1/4"  
FABRICADOS CON ACERO INOXIDABLE

p. 112



### ACR®

INSERTI 1/4" CON CRESTE ANTISCIVOLAMENTO  
1/4" BITS WITH NON-SLIP RIDGES • EMBOUTS 1/4" STRIURES ANTI-DÉRAPANTES • PUNTAS 1/4" CON  
CRESTAS ANTIDESLIZAMIENTO

p. 124

## INSERTI CON SISTEMA DI TRATTENIMENTO MAGNETICO

*1/4" bits with magnetic retention system*

*Embouts 1/4" avec bague de rétention magnétique*

*Puntas de 1/4" con sistema de retención magnético*

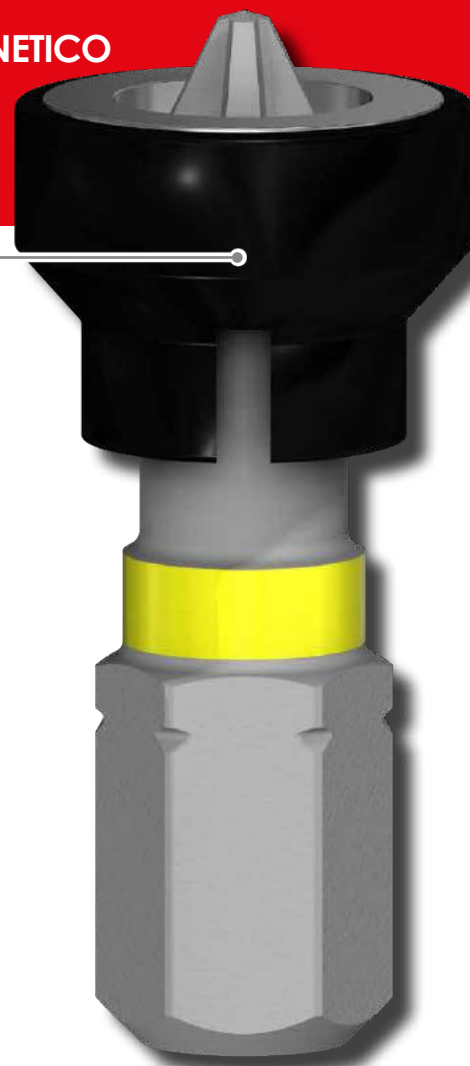

### MAG-Bit+™ system



**500g**  
TX10 - TX15

**600g**  
PH1 - PZ1  
TX20 - TX25

**750g**  
PH2 - PH3  
PZ2 - PZ3  
TX27 - TX30

**800g**  
TX40

### UTILIZZO

*Use / utilisation / uso*

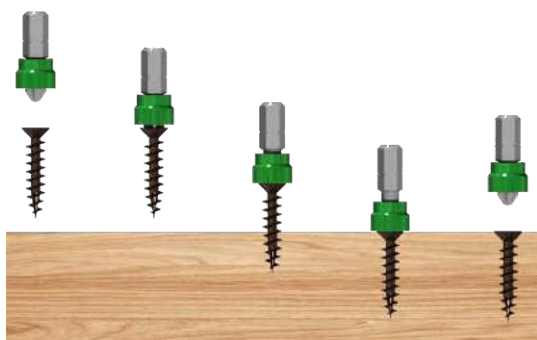

**Applicazioni**  
*applications*  
*aplicaciones*

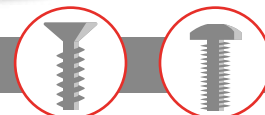

Trattenimento magnetico in quattro diversi formati e capacità per adattarsi correttamente ad ogni tipo e dimensione di vite.

*Magnetic retention system in four different sizes and capacities to suit every type and size of screw.*

*Bague de rétention magnétique dans quatre formats différents et la capacité de s'adapter correctement pour chaque type et taille de vis.*

*Sistema de retención magnético en cuatro formatos diferentes y la capacidad de adaptarse adecuadamente para cada tipo y tamaño de tornillo.*



Codice colore per un riconoscimento facile ed immediato sia della misura che del tipo di impronta.

*COLOUR code for easy and immediate recognition of the size and profile of screw.*

*Code couleur pour reconnaître facilement et immédiatement mesure et type de vis.*

*Un código de COLOUR para el reconocimiento fácil e inmediata de la medida y el tipo de huella.*



Sistema di trattenimento semplice e innovativo per risolvere molti problemi di avvitatura nel settore professionale.

*Innovative simple retention system to solve many screwdriving problems in the professional sector.*

*Système de retenue innovante et simple pour résoudre de nombreux problèmes de fixation dans le domaine professionnel.*

*Sistema de retención sencilla e innovadora para resolver muchos problemas de fijación en el campo profesional.*

**61355****PH MAG-Bit+™**

INSERTI 1/4" C PHILLIPS® CON TRATTENIMENTO MAGNETICO E CODICE COLORE  
1/4" C PHILLIPS® BITS WITH MAGNETIC RETENTION AND COLORED CODE  
EMBOUS 1/4" C PHILLIPS® AVEC RETENTION MAGNETIQUE ET CODE DE COULEUR  
PUNTAS DE 1/4" C PHILLIPS® CON RETENCIÓN MAGNETICA Y CÓDIGO DE COLOR

**NEW!**

58/60 HRC

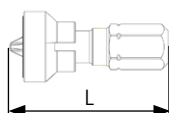
**EASYPACK** | sacchetto PVC con Euro-hole • PVC bags with Euro-hole

+	L mm	PCS.	COD.	€ cad./each
PH1	25	10	61355005	1,860
PH2	25	10	61355010	1,860
PH3	25	10	61355015	1,860



+	L mm	COD.	€ box
PH1	25	61355005002	5,040
PH2	25	61355010002	5,040
PH3	25	61355015002	5,040

**SELPACK**  
2 pcs.

+	L mm	COD.	€ box
PH1	25	61355005010	19,500
PH2	25	61355010010	19,500
PH3	25	61355015010	19,500

**MINIBOX**  
10 pcs.**61356****PH MAG-Bit+™**

LAME 1/4" E PHILLIPS® CON TRATTENIMENTO MAGNETICO E CODICE COLORE  
1/4" E PHILLIPS® POWER BITS WITH MAGNETIC RETENTION AND COLORED CODE  
EMBOUS 1/4" E PHILLIPS® AVEC RETENTION MAGNETIQUE ET CODE DE COULEUR  
PUNTAS DE 1/4" E PHILLIPS® CON RETENCIÓN MAGNETICA Y CÓDIGO DE COLOR

58/60 HRC

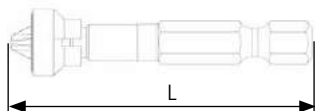
**EASYPACK** | sacchetto PVC con Euro-hole • PVC bags with Euro-hole**NEW!**

+	L mm	PCS.	COD.	€ cad./each
PH1	50	5	61356005	2,300
PH2	50	5	61356010	2,300
PH3	50	5	61356015	2,300



+	L mm	COD.	€ box
PH1	50	61356005002	5,900
PH2	50	61356010002	5,900
PH3	50	61356015002	5,900

**SELPACK**  
2 pcs.

+	L mm	COD.	€ box
PH1	50	61356005005	12,100
PH2	50	61356010005	12,100
PH3	50	61356015005	12,100

**MINIBOX**  
5 pcs.



# 1.1 LINEE PREMIUM

PREMIUM LINES  
LIGNES PREMIUM  
LÍNEAS PREMIUM

**61365**

**PZ MAG-Bit+™**



INSERTI 1/4" C POZIDRIV® CON TRATTENIMENTO MAGNETICO E CODICE COLORE  
1/4" C POZIDRIV® BITS WITH MAGNETIC RETENTION AND COLORED CODE  
EMBOUTS 1/4" C POZIDRIV® AVEC RETENTION MAGNETIQUE ET CODE DE COULEUR  
PUNTAS DE 1/4" C POZIDRIV® CON RETENCIÓN MAGNETICA Y CÓDIGO DE COLOR

**NEW!**

58/60 HRC

**EASYPACK** | sacchetto PVC con Euro-hole • PVC bags with Euro-hole

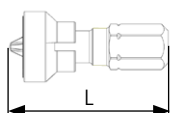
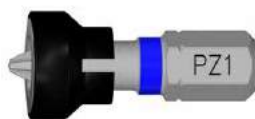

	L mm	PCS.	COD.	€ cad./each
<b>PZ1</b>	25	10	61365005	1,860
<b>PZ2</b>	25	10	61365010	1,860
<b>PZ3</b>	25	10	61365015	1,860



	L mm	COD.	€ box
<b>PZ1</b>	25	61365005002	5,040
<b>PZ2</b>	25	61365010002	5,040
<b>PZ3</b>	25	61365015002	5,040

**SELFPACK**  
2 pcs.



	L mm	COD.	€ box
<b>PZ1</b>	25	61365005010	19,500
<b>PZ2</b>	25	61365010010	19,500
<b>PZ3</b>	25	61365015010	19,500

**MINIBOX**  
10 pcs.

**61366**

**PZ MAG-Bit+™**



LAME 1/4" E POZIDRIV® CON TRATTENIMENTO MAGNETICO E CODICE COLORE  
1/4" E POZIDRIV® POWER BITS WITH MAGNETIC RETENTION AND COLORED CODE  
EMBOUTS 1/4" E POZIDRIV® AVEC RETENTION MAGNETIQUE ET CODE DE COULEUR  
PUNTAS DE 1/4" E POZIDRIV® CON RETENCIÓN MAGNETICA Y CÓDIGO DE COLOR

58/60 HRC

**EASYPACK** | sacchetto PVC con Euro-hole • PVC bags with Euro-hole

**NEW!**

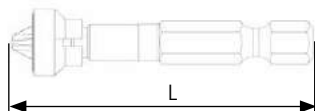

	L mm	PCS.	COD.	€ cad./each
<b>PZ1</b>	50	5	61366005	2,300
<b>PZ2</b>	50	5	61366010	2,300
<b>PZ3</b>	50	5	61366015	2,300



	L mm	COD.	€ box
<b>PZ1</b>	50	61366005002	5,900
<b>PZ2</b>	50	61366010002	5,900
<b>PZ3</b>	50	61366015002	5,900

**SELFPACK**  
2 pcs.



	L mm	COD.	€ box
<b>PZ1</b>	50	61366005005	12,100
<b>PZ2</b>	50	61366010005	12,100
<b>PZ3</b>	50	61366015005	12,100

**MINIBOX**  
5 pcs.



**61375 TX MAG-Bit+™**

INSERTI 1/4" C PER VITI TORX® CON TRATTENIMENTO MAGNETICO E CODICE COLORE  
 1/4" C BITS FOR TORX® SCREWS WITH MAGNETIC RETENTION AND COLORED CODE  
 EMBOUTS 1/4" C POUR VIS TORX® AVEC RETENTION MAGNETIQUE ET CODE DE COULEUR  
 PUNTAS DE 1/4" C PARA TORNILLOS TORX® CON RETENCIÓN MAGNETICA Y CÓDIGO DE COLOR

**NEW!**

58/60 HRC

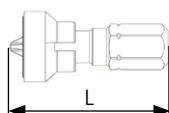
**EASYPACK** | sacchetto PVC con Euro-hole • PVC bags with Euro-hole

	L mm	PCS.	COD.	€ cad./each
<b>TX10</b>	25	10	61375005	2,260
<b>TX15</b>	25	10	61375010	2,260
<b>TX20</b>	25	10	61375015	2,260
<b>TX25</b>	25	10	61375020	2,260
<b>TX27</b>	25	10	61375025	2,260
<b>TX30</b>	25	10	61375030	2,260
<b>TX40</b>	25	10	61375035	2,260

	L mm	COD.	€ box
<b>TX10</b>	25	61375005002	5,800
<b>TX15</b>	25	61375010002	5,800
<b>TX20</b>	25	61375015002	5,800
<b>TX25</b>	25	61375020002	5,800
<b>TX27</b>	25	61375025002	5,800
<b>TX30</b>	25	61375030002	5,800
<b>TX40</b>	25	61375035002	5,800

	L mm	COD.	€ box
<b>TX10</b>	25	61375005010	23,800
<b>TX15</b>	25	61375010010	23,800
<b>TX20</b>	25	61375015010	23,800
<b>TX25</b>	25	61375020010	23,800
<b>TX27</b>	25	61375025010	23,800
<b>TX30</b>	25	61375030010	23,800
<b>TX40</b>	25	61375035010	23,800

**SELPACK**  
2 pcs.**MINIBOX**  
10 pcs.**61376 TX MAG-Bit+™**

LAME 1/4" E PER VITI TORX® CON TRATTENIMENTO MAGNETICO E CODICE COLORE  
 1/4" E POWER BITS FOR TORX® SCREWS WITH MAGNETIC RETENTION AND COLORED CODE  
 EMBOUTS 1/4" E POUR VIS TORX® AVEC RETENTION MAGNETIQUE ET CODE DE COULEUR  
 PUNTAS DE 1/4" E PARA TORNILLOS TORX® CON RETENCIÓN MAGNETICA Y CÓDIGO DE COLOR

**NEW!**

58/60 HRC

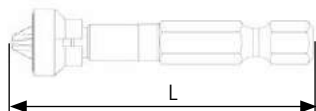
**EASYPACK** | sacchetto PVC con Euro-hole • PVC bags with Euro-hole

	L mm	PCS.	COD.	€ cad./each
<b>TX10</b>	50	5	61376005	2,780
<b>TX15</b>	50	5	61376010	2,780
<b>TX20</b>	50	5	61376015	2,780
<b>TX25</b>	50	5	61376020	2,780
<b>TX27</b>	50	5	61376025	2,780
<b>TX30</b>	50	5	61376030	2,780
<b>TX40</b>	50	5	61376035	2,780

	L mm	COD.	€ box
<b>TX10</b>	50	61376005002	6,900
<b>TX15</b>	50	61376010002	6,900
<b>TX20</b>	50	61376015002	6,900
<b>TX25</b>	50	61376020002	6,900
<b>TX27</b>	50	61376025002	6,900
<b>TX30</b>	50	61376030002	6,900
<b>TX40</b>	50	61376035002	6,900

	L mm	COD.	€ box
<b>TX10</b>	50	61376005005	14,600
<b>TX15</b>	50	61376010005	14,600
<b>TX20</b>	50	61376015005	14,600
<b>TX25</b>	50	61376020005	14,600
<b>TX27</b>	50	61376025005	14,600
<b>TX30</b>	50	61376030005	14,600
<b>TX40</b>	50	61376035005	14,600

**SELPACK**  
2 pcs.**MINIBOX**  
5 pcs.



# 1.1 LINEE PREMIUM

PREMIUM LINES  
LIGNES PREMIUM  
LÍNEAS PREMIUM

66002

**MYBIT 7**

ASSORTIMENTI MAG-Bit+™

ASSORTIMENTO 7 PCS. - INSERTI + PORTAINSERI  
7 PCS. SET - BITS + BIT HOLDER  
JEU 7 PCS. - EMBOUTS + PORTE-EMBOUTS  
JUEGO 7 PCS. - PUNTAS + PORTA PUNTAS

**NEW!**



7  
pcs.

COD. **66002445**

€ 18,600



PH1  
1pc.

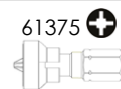

PH2  
1pc.



PZ1  
1pc.

PZ2  
1pc.

TX25  
1pc.

TX30  
1pc.

COD. **66002450**

€ 21,000



TX10  
1pc.

TX15  
1pc.

TX20  
1pc.

TX25  
1pc.

TX30  
1pc.

TX40  
1pc.



100 X 120 mm



INCLUSO / INCLUDED  
INCLUDE / INCLUIDO  
COD. 62013005



66002

**DISPLAY MYBIT 7**  
MAG-Bit+™

ESPOSITORE DA BANCO IN PLEXIGLASS PER 12 BIT-SET  
12 PCS. BIT-SETS PLEXIGLASS COUNTER DISPLAY  
PRÉSENTOIR EN PLEXIGLASS POUR 12 JEUX D'EMBOUTS  
MOSTRADOR DE EXPOSICIÓN IN PLEXIGLASS PARA 12 BIT-SET

**NEW!**



12  
pcs.

COD. **66002449**

€ 223,000



12 pcs.  
COD. 66002445

COD. **66002454**

€ 252,000



12 pcs.  
COD. 66002450

150 X 40 X 195 mm

**66001****STORE 9****ASSORTIMENTI MAG-Bit+™**

CASSETTIERA CON 9 SCOMPARTI PER ESPOSITORE MULTISTORE  
 DRAWERS WITH 9 COMPARTMENTS FOR MULTISTORE DISPLAY  
 TIROIRS AVEC 9 COMPARTIMENTS POUR PRESENTOIR MULTISTORE  
 9 CAJONES PARA MOSTRADOR DE EXPOSICIÓN TIPO MULTISTORE

COD. **66001080**€ **219,000**110  
pcs.

600 X 90 X 65 mm

61355			61365		61375			
PH1	PH2	PH3	PZ1	PZ2	TX20	TX25	TX30	TX40
10pcs.	20pcs.	10pcs.	10pcs.	20pcs.	10pcs.	10pcs.	10pcs.	10pcs.

**MULTI STORE**

COD. 66001005VC

PER DETTAGLI E COMPOSIZIONE VEDERE P. 184  
 FOR DETAILS AND COMPOSITION SEE P. 184  
 POUR LES DÉTAILS ET LA COMPOSITION VOIR P. 184  
 PARA MÁS DETALLES Y COMPOSICIÓN VÉASE P. 184



# 1.1 LINEE PREMIUM

PREMIUM LINES  
LIGNES PREMIUM  
LÍNEAS PREMIUM

66001

**MULTI BIT**

ESPOSITORE INSERTI MAG-Bit+™

ESPOSITORE DA BANCO CON 25 SCOMPARTI  
COUNTER DISPLAY WITH 25 COMPARTMENTS  
PRÉSENTOIR DE COMPTOIR À 25 LOGEMENTS  
MOSTRADOR DE EXPOSICIÓN DE 25 ALOJAMIENTOS



260  
pcs.

COD. **66001340**

€ 642,000

61355



PH1 10pcs.	PH2 20pcs.	PH3 10pcs.	PZ1 10pcs.	PZ2 20pcs.	PZ3 10pcs.
---------------	---------------	---------------	---------------	---------------	---------------

61365



61375



TX10 10pcs.	TX15 10pcs.	TX20 10pcs.	TX25 20pcs.	TX30 20pcs.	TX40 20pcs.
----------------	----------------	----------------	----------------	----------------	----------------

61356



PH1 5pcs.	PH2 10pcs.	PH3 5pcs.	PZ1 5pcs.	PZ2 10pcs.	PZ3 5pcs.
--------------	---------------	--------------	--------------	---------------	--------------

61366



61376



TX10 5pcs.	TX15 5pcs.	TX20 5pcs.	TX25 10pcs.	TX30 10pcs.	TX40 10pcs.
---------------	---------------	---------------	----------------	----------------	----------------

62018005



5pcs.

445 X 465 X 210 mm

STRUTTURA IN POLIPROPILENE ALVEOLARE AUTOPORTANTE, 25 SCOMPARTI.  
SELF-SUPPORTING POLYPROPYLENE HONEYCOMB STRUCTURE, 25 COMPARTMENTS.  
STRUCTURE EN POLYPROPYLÈNE ALVÉOLAIRE AUTOPORTANTE, 25 LOGEMENTS.  
ESTRUCTURA DE POLIPROPILENO ALVEOLAR AUTOSUSTENTADA, 25 ALOJAMIENTOS.



*L'utilizzo degli inserti MAG-Bit+ permette di lavorare con una mano libera.*  
*The use of MAG-Bit+ bits allows you to work with a free hand.*  
*L'utilisation des embouts MAG-Bit+ vous permet de travailler avec les mains libres.*  
*El uso de las puntas MAG-Bit+ le permite trabajar con una mano libre.*



### INSERTI 1/4" TORSION CON ANELLO COLORATO

1/4" colored ring torsion bits

Embouts 1/4" torsion avec bague de couleur

Puntas de 1/4" torsion con anillo de color

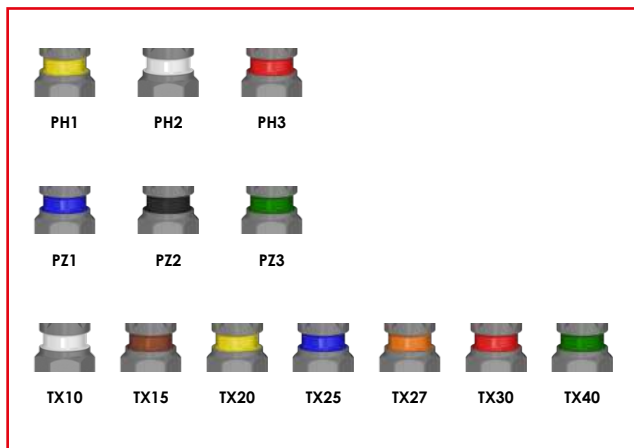

Incisione laser della misura  
Laser marking of size  
Marquage laser de la taille  
Marcado láser del tamaño

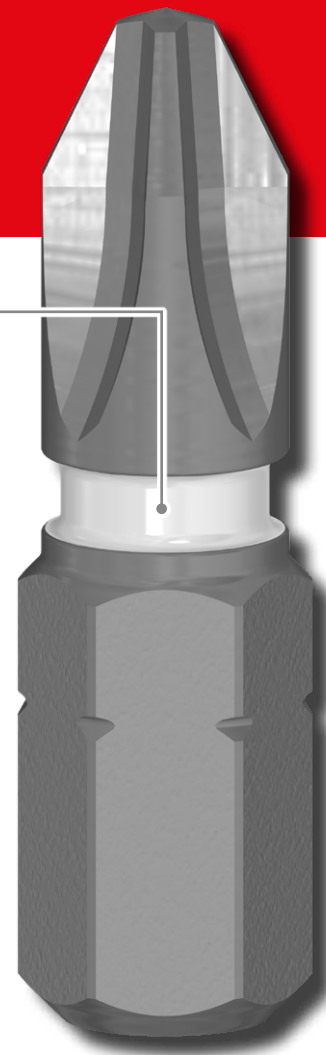

Applicazioni  
applications  
applications  
aplicaciones

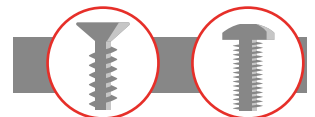

Collare verniciato resistente all'olio e ai solventi per sopportare qualsiasi condizione di lavoro.

*Oil and solvents resistant painted ring to withstand any working condition.*

*Bague peinte résistant à l'huile et aux solvants pour résister à toutes les conditions de travail.*

*Collar pintado resistente al aceite y disolventes para soportar cualquier condición de trabajo.*



L'esclusivo design permette di disperdere lo sforzo di torsione lungo tutto l'utensilio.

*The exclusive design allows distributing the torsional stress along the entire length of the tool.*

*Le design exclusif permet de disperser la contrainte de torsion tout au long de l'outil.*

*El exclusivo diseño permite distribuir el esfuerzo de torsión a lo largo de todo el utensilio.*



Gamma completa delle misure più richieste e utilizzate sul mercato di due differenti lunghezze.

*Full range of the most requested and used sizes on the market in two different lengths.*

*Une gamme complète de grandeurs plus demandée et utilisée sur le marché avec deux longueurs différentes.*

*Una amplia gama de magnitudes más solicitado y utilizado en el mercado con dos longitudes diferentes.*

**61450****PH COLOUR+**

INSERTI 1/4" C PHILLIPS® CON CODICE COLORE  
 1/4" C PHILLIPS® BITS WITH COLORED CODE  
 EMBOUTS 1/4" C PHILLIPS® AVEC CODE DE COULEUR  
 PUNTAS DE 1/4" C PHILLIPS® CON CÓDIGO DE COLOR

**NEW!**

58/60 HRC

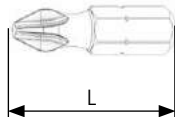
**EASYPACK** | sacchetto PVC con Euro-hole • PVC bags with Euro-hole

	L mm	PCS.	COD.	€ cad./each
PH1	25	10	61450005	0,880
PH2	25	10	61450010	0,880
PH3	25	10	61450015	0,880

**SELPACK**  
2 pcs.

	L mm	COD.	€ box
PH1	25	61450005002	3,040
PH2	25	61450010002	3,040
PH3	25	61450015002	3,040

**MINIBOX**  
10 pcs.

	L mm	COD.	€ box
PH1	25	61450005010	9,630
PH2	25	61450010010	9,630
PH3	25	61450015010	9,630

**61451****PH COLOUR+**

LAME 1/4" E PHILLIPS® CON CODICE COLORE  
 1/4" E PHILLIPS® POWER BITS WITH COLORED CODE  
 EMBOUTS 1/4" E PHILLIPS® AVEC CODE DE COULEUR  
 PUNTAS DE 1/4" E PHILLIPS® CON CÓDIGO DE COLOR

**NEW!**

58/60 HRC

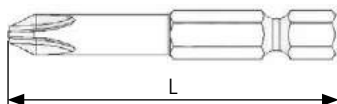
**EASYPACK** | sacchetto PVC con Euro-hole • PVC bags with Euro-hole

	L mm	PCS.	COD.	€ cad./each
PH1	50	5	61451005	1,830
PH2	50	5	61451010	1,830
PH3	50	5	61451015	1,830

**SELPACK**  
2 pcs.

	L mm	COD.	€ box
PH1	50	61451005002	4,950
PH2	50	61451010002	4,950
PH3	50	61451015002	4,950

**MINIBOX**  
5 pcs.

	L mm	COD.	€ box
PH1	50	61451005005	9,610
PH2	50	61451010005	9,610
PH3	50	61451015005	9,610



# 1.1 LINEE PREMIUM

PREMIUM LINES  
LIGNES PREMIUM  
LÍNEAS PREMIUM

61460

PZ COLOUR+



INSERTI 1/4"C POZIDRIV® CON CODICE COLORE  
1/4"C POZIDRIV® BITS WITH COLORED CODE  
EMBOUTS 1/4"C POZIDRIV® AVEC CODE DE COULEUR  
PUNTAS DE 1/4"C POZIDRIV® CON CÓDIGO DE COLOR

**NEW!**

58/60 HRC

EASYPACK | sacchetto PVC con Euro-hole • PVC bags with Euro-hole

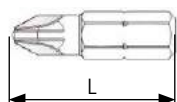

	L mm	PCS.	COD.	€ cad./each
PZ1	25	10	61460005	0,880
PZ2	25	10	61460010	0,880
PZ3	25	10	61460015	0,880



	L mm	COD.	€ box
PZ1	25	61460005002	3,040
PZ2	25	61460010002	3,040
PZ3	25	61460015002	3,040

SELFPACK  
2 pcs.



	L mm	COD.	€ box
PZ1	25	61460005010	9,630
PZ2	25	61460010010	9,630
PZ3	25	61460015010	9,630

MINIBOX  
10 pcs.

61461

PZ COLOUR+



LAME 1/4"E POZIDRIV® CON CODICE COLORE  
1/4"E POZIDRIV® POWER BITS WITH COLORED CODE  
EMBOUTS 1/4"E POZIDRIV® AVEC CODE DE COULEUR  
PUNTAS DE 1/4"E POZIDRIV® CON CÓDIGO DE COLOR

**NEW!**

58/60 HRC

EASYPACK | sacchetto PVC con Euro-hole • PVC bags with Euro-hole

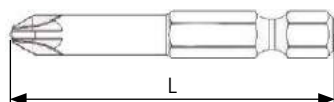

	L mm	PCS.	COD.	€ cad./each
PZ1	50	5	61461005	1,830
PZ2	50	5	61461010	1,830
PZ3	50	5	61461015	1,830



	L mm	COD.	€ box
PZ1	50	61461005002	4,950
PZ2	50	61461010002	4,950
PZ3	50	61461015002	4,950

SELFPACK  
2 pcs.



	L mm	COD.	€ box
PZ1	50	61461005005	9,610
PZ2	50	61461010005	9,610
PZ3	50	61461015005	9,610

MINIBOX  
5 pcs.



**61470** TX COLOUR+ 

INSERTI 1/4" PER VITI TORX® CON CODICE COLORE  
1/4" BITS FOR TORX® SCREWS WITH COLORED CODE  
EMBOUTS 1/4" POUR VIS TORX® AVEC CODE DE COULEUR  
PUNTAS DE 1/4" PARA TORNILLOS TORX® CON CÓDIGO DE COLOR

**NEW!**

58/60 HRC

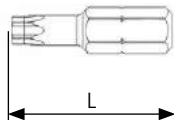
**EASYPACK** | sacchetto PVC con Euro-hole • PVC bags with Euro-hole

	L mm	PCS.	COD.	€ cad./each
<b>TX10</b>	25	10	61470005	1,090
<b>TX15</b>	25	10	61470010	1,090
<b>TX20</b>	25	10	61470015	1,090
<b>TX25</b>	25	10	61470020	1,090
<b>TX27</b>	25	10	61470025	1,090
<b>TX30</b>	25	10	61470030	1,090
<b>TX40</b>	25	10	61470035	1,090

	L mm	COD.	€ box
<b>TX10</b>	25	61470005002	3,450
<b>TX15</b>	25	61470010002	3,450
<b>TX20</b>	25	61470015002	3,450
<b>TX25</b>	25	61470020002	3,450
<b>TX27</b>	25	61470025002	3,450
<b>TX30</b>	25	61470030002	3,450
<b>TX40</b>	25	61470035002	3,450

**SELPACK**  
2 pcs.**MINIBOX**  
10 pcs.

	L mm	COD.	€ box
<b>TX10</b>	25	61470005010	11,900
<b>TX15</b>	25	61470010010	11,900
<b>TX20</b>	25	61470015010	11,900
<b>TX25</b>	25	61470020010	11,900
<b>TX27</b>	25	61470025010	11,900
<b>TX30</b>	25	61470030010	11,900
<b>TX40</b>	25	61470035010	11,900

**61471** TX COLOUR+ 

LAME 1/4"E PER VITI TORX® CON CODICE COLORE  
1/4"E POWER BITS FOR TORX® SCREWS WITH COLORED CODE  
EMBOUTS 1/4"E POUR VIS TORX® AVEC CODE DE COULEUR  
PUNTAS DE 1/4"E PARA TORNILLOS TORX® CON CÓDIGO DE COLOR

**NEW!**

58/60 HRC

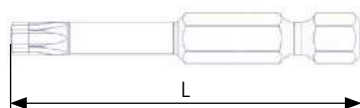
**EASYPACK** | sacchetto PVC con Euro-hole • PVC bags with Euro-hole

	L mm	PCS.	COD.	€ cad./each
<b>TX10</b>	50	5	61471005	3,330
<b>TX15</b>	50	5	61471010	3,330
<b>TX20</b>	50	5	61471015	3,330
<b>TX25</b>	50	5	61471020	3,330
<b>TX27</b>	50	5	61471025	3,330
<b>TX30</b>	50	5	61471030	3,330
<b>TX40</b>	50	5	61471035	3,330

	L mm	COD.	€ box
<b>TX10</b>	50	61471005002	7,940
<b>TX15</b>	50	61471010002	7,940
<b>TX20</b>	50	61471015002	7,940
<b>TX25</b>	50	61471020002	7,940
<b>TX27</b>	50	61471025002	7,940
<b>TX30</b>	50	61471030002	7,940
<b>TX40</b>	50	61471035002	7,940

**SELPACK**  
2 pcs.**MINIBOX**  
5 pcs.

	L mm	COD.	€ box
<b>TX10</b>	50	61471005005	17,500
<b>TX15</b>	50	61471010005	17,500
<b>TX20</b>	50	61471015005	17,500
<b>TX25</b>	50	61471020005	17,500
<b>TX27</b>	50	61471025005	17,500
<b>TX30</b>	50	61471030005	17,500
<b>TX40</b>	50	61471035005	17,500



# 1.1 LINEE PREMIUM

PREMIUM LINES  
LIGNES PREMIUM  
LÍNEAS PREMIUM

**66002**

## MYBIT 7 ASSORTIMENTI COLOUR+

ASSORTIMENTO 7 PCS. - INSERTI + PORTAINSERTI  
7 PCS. SET - BITS + BIT HOLDER  
JEU 7 PCS. - EMBOUTS + PORTE-EMBOUTS  
JUEGO 7 PCS. - PUNTAS + PORTA PUNTAS

**NEW!**



7  
pcs.



100 X 120 mm



INCLUSO / INCLUDED  
INCLUSE / INCLUIDO



COD. 62013005



COD. **66002430**

€ 11,300



PH1 | PH2 | PH3  
1pc. | 1pc. | 1pc.



PZ1 | PZ2 | PZ3  
1pc. | 1pc. | 1pc.

COD. **66002435**

€ 11,400



TX10 | TX15 | TX20 | TX25 | TX30 | TX40  
1pc. | 1pc. | 1pc. | 1pc. | 1pc. | 1pc.

COD. **66002440**

€ 11,400



PH1 | PH2  
1pc. | 1pc.



PZ1 | PZ2  
1pc. | 1pc.



TX20 | TX25  
1pc. | 1pc.

**66002**

## DISPLAY MYBIT 7 COLOUR+

ESPOSITORE DA BANCO IN PLEXIGLASS PER 12 BIT-SET  
12 PCS. BIT-SETS PLEXIGLASS COUNTER DISPLAY  
PRÉSENTOIR EN PLEXIGLASS POUR 12 JEUX D'EMBOUTS  
MOSTRADOR DE EXPOSICIÓN IN PLEXIGLASS PARA 12 BIT-SET

**NEW!**



12  
pcs.

150 X 40 X 195 mm

COD. **66002434**

€ 135,600



12 pcs.  
COD. 66002430

COD. **66002439**

€ 136,800



12 pcs.  
COD. 66002435

COD. **66002444**

€ 136,800



12 pcs.  
COD. 66002440



66007

MYBIT 7 POWER

ASSORTIMENTI COLOUR+

ASSORTIMENTO 7 PCS. - INSERTI  
7 PCS. SET - BITS  
JEU 7 PCS. - EMBOUTS  
JUEGO 7 PCS. - PUNTAS

NEW!



7 pcs.

COD. 66007430

€ 15,500

61451  L=50mm		61461  L=50mm		61471  L=50mm		
PH1 1pc.	PH2 1pc.	PZ1 1pc.	PZ2 1pc.	TX25 1pc.	TX30 1pc.	TX40 1pc.

COD. 66007435

€ 11,600

61451  L=50mm			61461  L=50mm		
PH1 1pc.	PH2 2pcs.	PH3 1pc.	PZ1 1pc.	PZ2 1pc.	PZ3 1pc.



100 X 120 mm





# 1.1 LINEE PREMIUM

PREMIUM LINES  
LIGNES PREMIUM  
LÍNEAS PREMIUM

## 66005 MYBIT 10 ASSORTIMENTI COLOUR+

ASSORTIMENTO 10 PCS. - INSERTI + PORTAINSERI  
10 PCS. SET - BITS + BIT HOLDER  
JEU 10 PCS. - EMBOUTS + PORTE-EMBOUTS  
JUEGO 10 PCS. - PUNTAS + PORTA PUNTAS

**NEW!**



10 pcs.



100 X 120 mm



INCLUSO / INCLUDED  
INCLUDE / INCLUIDO  
COD. 62013005



COD. **66005430**

€ 13,100

61450			61460			61470		
PH1	PH2	PH3	PZ1	PZ2	PZ3	TX25	TX30	TX40
1pc.	1pc.	1pc.	1pc.	1pc.	1pc.	1pc.	1pc.	1pc.

COD. **66005435**

€ 13,100

61450			61460			61470		
PH2	PH3		PZ2	PZ3		TX30	TX40	
2pcs.	1pc.		2pcs.	1pc.		1pc.	2pcs.	

COD. **66005440**

€ 13,400

61450			61460			61470		
PH2	PH3		PZ2	PZ3	TX20	TX25	TX30	TX40
2pcs.	1pc.		1pc.	1pc.	1pc.	1pc.	1pc.	1pc.

## 66005 DISPLAY MYBIT 10 COLOUR+

ESPOSITORE DA BANCO IN PLEXIGLASS PER 12 BIT-SET  
12 PCS. BIT-SETS PLEXIGLASS COUNTER DISPLAY  
PRESENTOIR EN PLEXIGLASS POUR 12 JEUX DE EMBOUTS  
MOSTRADOR DE EXPOSICIÓN IN PLEXIGLASS PARA 12 BIT-SET

**NEW!**



12 pcs.

150 X 40 X 195 mm

COD. **66005434**

€ 157,200



12 pcs.  
COD. 66005430

COD. **66005439**

€ 157,200



12 pcs.  
COD. 66005435

COD. **66005444**

€ 160,800



12 pcs.  
COD. 66005440



**66006** **MYBIT 15**  
ASSORTIMENTI COLOUR+

ASSORTIMENTO 15 PCS. - INSERTI + PORTAINSERI  
15 PCS. SET - BITS + BIT-HOLDER  
JEU 15 PCS. - EMBOUTS + PORTE-EMBOUTS  
JUEGO DE 15 PCS. - PUNTAS + PORTA PUNTAS

**NEW!**

15 pcs.



100 X 167 mm



COD. **66006030**  
€ 19,300

<p>61450 </p>			<p>61460 </p>		
PH1 1pc.	PH2 1pc.	PH3 1pc.	PZ1 1pc.	PZ2 1pc.	PZ3 1pc.
<p>61470 </p>			<p></p>		
TX15 1pc.	TX20 1pc.	TX25 1pc.	4,5x0,6 1pc.	5,0x0,8 1pc.	6,5x1,2 1pc.
<p>61451 </p>			<p>61461 </p>		
PH2 1pc.			PZ2 1pc.		

INCLUSO / INCLUDED  
INCLUDE / INCLUIDO  
COD. 62013005

**66006** **DISPLAY MYBIT 15**  
COLOUR+

ESPOSITORE DA BANCO IN PLEXIGLASS PER 12 BIT-SET  
12 PCS. BIT-SETS PLEXIGLASS COUNTER DISPLAY  
PRESENTOIR EN PLEXIGLASS POUR 12 JEUX DE EMBOUTS  
MOSTRADOR DE EXPOSICÒN IN PLEXIGLASS PARA 12 BIT-SET

**NEW!**

12 pcs.



185 X 40 X 195 mm

COD. **66006034**  
€ 232,000



12 pcs.  
COD. 66006030



# 1.1 LINEE PREMIUM

PREMIUM LINES  
LIGNES PREMIUM  
LÍNEAS PREMIUM

**66006**

**MYBIT 14 COLOUR+ CON CRICCHETTO**

ASSORTIMENTO 14 PCS. COLOUR+ / CRICCHETTO  
14 PCS. SET - BITS + BIT HOLDER AND RATCHET  
JEU 14 PCS. - EMBOUTS + PORTE-EMBOUTS  
JUEGO DE 14 PCS. - PUNTAS + PORTA PUNTAS

**NEW!**



14  
pcs.

COD. **66006530**

€ 29,700

61450



61460



PH1	PH2	PH3	PZ1	PZ2	PZ3
1pc.	1pc.	1pc.	1pc.	1pc.	1pc.

61470



TX10	TX15	TX20	TX25	TX30	TX40
1pc.	1pc.	1pc.	1pc.	1pc.	1pc.



100 X 170 mm



INCLUSO / INCLUDED  
INCLUDE / INCLUIDO

COD. 62013005



COD. 64221030





**66001**

**STORE 9**

ASSORTIMENTI COLOUR+

CASSETTIERA CON 9 SCOMPARTI PER ESPOSITORE MULTISTORE  
DRAWER WITH 9 COMPARTMENTS FOR MULTISTORE DISPLAY  
TIROIRS AVEC 9 COMPARTIMENTS POUR PRESENTOIR MULTISTORE  
9 CAJONES PARA MOSTRADOR DE EXPOSICIÓN TIPO MULTISTORE

**NEW!**

200  
pcs.



600 X 90 X 65 mm

COD. **66001085**

€ 132,000

61450			61460			61470		
PH1	PH2	PH3	PZ1	PZ2	PZ3	TX20	TX25	TX30
20pcs.	30pcs.	20pcs.	20pcs.	30pcs.	20pcs.	20pcs.	20pcs.	20pcs.



**MULTI STORE**

COD. 66001005VC

PER DETTAGLI E COMPOSIZIONE VEDERE P. 184  
FOR DETAILS AND COMPOSITION SEE P. 184  
POUR LES DÉTAILS ET LA COMPOSITION VOIR P. 184  
PARA MÁS DETALLES Y COMPOSICIÓN VÉASE P. 184



# 1.1 LINEE PREMIUM

PREMIUM LINES  
LIGNES PREMIUM  
LÍNEAS PREMIUM

66001

**MULTI BIT**

ESPOSITORE INSERTI COLOUR+

ESPOSITORE DA BANCO CON 25 SCOMPARTI  
COUNTER DISPLAY WITH 25 COMPARTMENTS  
PRÉSENTOIR DE COMPTOIR À 25 LOGEMENTS  
MOSTRADOR DE EXPOSICIÓN DE 25 ALOJAMIENTOS

**NEW!**

290  
pcs.



445 X 465 X 210 mm

STRUTTURA IN POLIPROPILENE ALVEOLARE AUTOPORTANTE, 25 SCOMPARTI.  
SELF-SUPPORTING POLYPROPYLENE HONEYCOMB STRUCTURE, 25 COMPARTMENTS.  
STRUCTURE EN POLYPROPYLÈNE ALVÉOLAIRE AUTOPORTANTE, 25 LOGEMENTS.  
ESTRUCTURA DE POLIPROPILENO ALVEOLAR AUTOSUSTENTADA, 25 ALOJAMIENTOS.

COD. **66001345**

€ 342,000

61450			61460		
PH1 10pcs.	PH2 20pcs.	PH3 10pcs.	PZ1 10pcs.	PZ2 20pcs.	PZ3 10pcs.

61470					
TX10 10pcs.	TX15 10pcs.	TX20 10pcs.	TX25 20pcs.	TX30 20pcs.	TX40 20pcs.

61451			61461		
PH1 10pcs.	PH2 10pcs.	PH3 10pcs.	PZ1 10pcs.	PZ2 10pcs.	PZ3 10pcs.

61471					
TX10 5pcs.	TX15 5pcs.	TX20 10pcs.	TX25 10pcs.	TX30 10pcs.	TX40 10pcs.

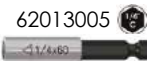

10pcs.



**66001****MULTIBOX****ESPOSITORE MINIBOX COLOUR+**

ESPOSITORE DA BANCO IN FILO METALLICO PER MINIBOX  
 METAL WIRE COUNTER DISPLAY FOR MINIBOX  
 PRÉSENTOIR DE COMPTOIR EN FIL MÉTALLIQUE POUR MINIBOX  
 MOSTRADOR DE EXPOSICIÓN DE ALAMBRE PARA MINIBOX

**NEW!****470  
pcs.**
**COD. 66001535**  
**€ 528,000**
**370 X 545 X 220 mm**

STRUTTURA IN FILO METALLICO DA BANCO ED APPENDIBILE ADATA AD ACCOGLIERE 20 MISURE DIVERSE DI INSERTI CONFEZIONATI IN MINIBOX E DUE ARTICOLI ACCESSORI.

COUNTERTOP OR WALL-MOUNTED METAL WIRE STRUCTURE, SUITABLE FOR HOLDING BITS IN 20 DIFFERENT SIZES, MINIBOX PACKED AND TWO ACCESSORIES.

STRUCTURE EN FIL MÉTALLIQUE DE COMPTOIR ET À SUSPENDRE, ADAPTÉE POUR 20 TAILLES DIFFÉRENTES D'EMBOÛTS EMBALLÉS DANS UNE MINI-BOÎTE ET DEUX ARTICLES ACCESSOIRES.

ESTRUCTURA DE HILO METÁLICO PARA MOSTRADOR QUE SE PUEDE COLGAR APTA PARA ALOJAR 20 DIFERENTES MEDIDAS DE PUNTAS PUESTOS EN MINICAJAS MÁS DOS ARTÍCULOS DE ACCESORIOS.

			L mm	COD.	box
10 pcs.		<b>PH1</b>	25	61450005010	4
10 pcs.		<b>PH2</b>	25	61450010010	4
10 pcs.		<b>PH3</b>	25	61450015010	4
10 pcs.		<b>PZ1</b>	25	61460005010	4
10 pcs.		<b>PZ2</b>	25	61460010010	4
10 pcs.		<b>PZ3</b>	25	61460015010	4
10 pcs.		<b>TX20</b>	25	61470015010	3
10 pcs.		<b>TX25</b>	25	61470020010	3
10 pcs.		<b>TX30</b>	25	61470030010	3
10 pcs.		<b>TX40</b>	25	61470035010	3
5 pcs.		<b>PH1</b>	50	61451005005	2
5 pcs.		<b>PH2</b>	50	61451010005	2
5 pcs.		<b>PH3</b>	50	61451015005	2
5 pcs.		<b>PZ1</b>	50	61461005005	2
5 pcs.		<b>PZ2</b>	50	61461010005	2
5 pcs.		<b>PZ3</b>	50	61461015005	2
5 pcs.		<b>TX20</b>	50	61471015005	2
5 pcs.		<b>TX25</b>	50	61471020005	2
5 pcs.		<b>TX30</b>	50	61471030005	2
5 pcs.		<b>TX40</b>	50	61471035005	2
1 pc.				62029005	4
1 pc.				62015010001	6



## INSERTI 1/4" PER AVVITATORI A MASSA BATTENTE

1/4" bits for impact wrenches

Embouts 1/4" pour visseuses à masse battante

Puntas de 1/4" para atornilladores de impacto



### RESISTENZA AGLI IMPULSI

high pulse strength / résistance aux impulsions / resistencia a los impulsos

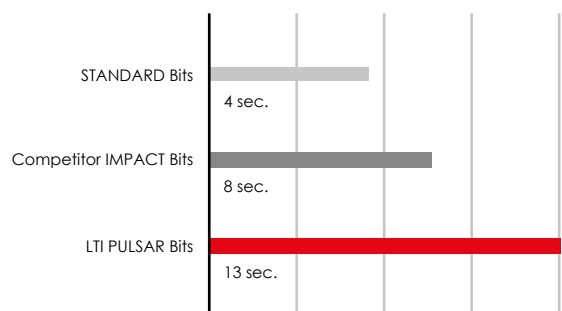

### ANGOLO DI TORSIONE

torsion angle / angle de torsion / angulo de torsión

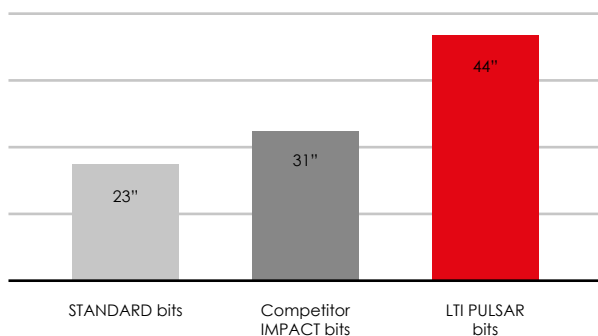

Applicazioni  
applications  
applications  
aplicaciones

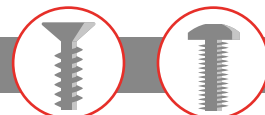

Progettati e testati per l'uso con avvitatori a massa battente.

*Designed and tested for use with impact wrenches.*

*Conçus et testés pour l'utilisation avec visseuses à masse battante.*

*Diseñados y probados para el uso con atornilladores de impacto.*



Alta resistenza agli impulsi, anche ad elevate velocità. Sopporta le sollecitazioni fino al 300% in più di un inserto tradizionale.

*High pulse strength, even at high speeds. Withstands stress up to 300% higher than traditional bits.*

*Haute résistance aux impulsions, même à haute vitesse. Supporte les contraintes jusqu'à 300 % de plus qu'un embout traditionnel.*

*Alta resistencia a los impulsos, incluso con grandes velocidades. Resiste a esfuerzos hasta el 300% de más comparado con una punta tradicional.*



Profilo ridotto per ottimizzare la resistenza agli sforzi di torsione, assorbe una deformazione doppia rispetto al normale.

*Reduced profile to optimise resistance to twisting, withstands twice the deformation of normal bits.*

*Profil réduit pour optimiser la résistance aux contraintes de torsion, qui absorbe une déformation double par rapport à la normale.*

*Perfil reducido para optimizar la resistencia a los esfuerzos de torsión, absorbe una deformación doble con respecto a lo normal.*

**61210****PH PULSAR®**

INSERTI 1/4" C PHILLIPS® - PER AVVITATORI A MASSA BATTENTE  
 1/4" C PHILLIPS® BITS - FOR IMPACT WRENCHES  
 EMBOUTS 1/4" C PHILLIPS® - POUR VISSEUSE À CHOCS  
 PUNTAS DE 1/4" C PHILLIPS® - PARA ATORNILLADORES DE IMPACTO

58/60 HRC

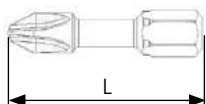
**EASYPACK** | sacchetto PVC con Euro-hole • PVC bags with Euro-hole

+	L mm	PCS.	COD.	€ cad./each
PH1	30	10	61210005	1,850
PH2	30	10	61210010	1,850
PH3	30	10	61210015	1,850

**SELPACK**  
2 pcs.

+	L mm	COD.	€ box
PH1	30	61210005002	5,040
PH2	30	61210010002	5,040
PH3	30	61210015002	5,040

**MINIBOX**  
10 pcs.

+	L mm	COD.	€ box
PH1	30	61210005010	19,500
PH2	30	61210010010	19,500
PH3	30	61210015010	19,500

**61211****PH PULSAR®**

LAME 1/4" E PHILLIPS® - PER AVVITATORI A MASSA BATTENTE  
 1/4" E PHILLIPS® POWER BITS - FOR IMPACT WRENCHES  
 EMBOUTS 1/4" E PHILLIPS® - POUR VISSEUSE À CHOCS  
 PUNTAS DE 1/4" E PHILLIPS® - PARA ATORNILLADORES DE IMPACTO

58/60 HRC

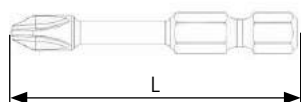
**EASYPACK** | sacchetto PVC con Euro-hole • PVC bags with Euro-hole

+	L mm	PCS.	COD.	€ cad./each
PH1	50	5	61211005	3,250
PH2	50	5	61211010	3,250
PH3	50	5	61211015	3,250

**SELPACK**  
2 pcs.

+	L mm	COD.	€ box
PH1	50	61211005002	7,820
PH2	50	61211010002	7,820
PH3	50	61211015002	7,820

**MINIBOX**  
5 pcs.

+	L mm	COD.	€ box
PH1	50	61211005005	17,100
PH2	50	61211010005	17,100
PH3	50	61211015005	17,100



# 1.1 LINEE PREMIUM

PREMIUM LINES  
LIGNES PREMIUM  
LÍNEAS PREMIUM

**61220**

**PZ PULSAR®**



INSERTI 1/4"C POZIDRIV® - PER AVVITATORI A MASSA BATTENTE  
1/4"C POZIDRIV® BITS - FOR IMPACT WRENCHES  
EMBOUS 1/4"C POZIDRIV® - POUR VISSEUSE À CHOCS  
PUNTAS DE 1/4"C POZIDRIV® - PARA ATORNILLADORES DE IMPACTO

58/60 HRC

**EASYPACK** | sacchetto PVC con Euro-hole • PVC bags with Euro-hole



	L mm	PCS.	COD.	€ cad./each
<b>PZ1</b>	30	10	61220005	1,850
<b>PZ2</b>	30	10	61220010	1,850
<b>PZ3</b>	30	10	61220015	1,850

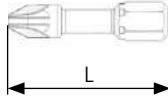

**SELPACK**  
2 pcs.

	L mm	COD.	€ box
<b>PZ1</b>	30	61220005002	5,040
<b>PZ2</b>	30	61220010002	5,040
<b>PZ3</b>	30	61220015002	5,040



**MINIBOX**  
10 pcs.

	L mm	COD.	€ box
<b>PZ1</b>	30	61220005010	19,500
<b>PZ2</b>	30	61220010010	19,500
<b>PZ3</b>	30	61220015010	19,500

**61221**

**PZ PULSAR®**



LAME 1/4"E POZIDRIV® - PER AVVITATORI A MASSA BATTENTE  
1/4"E POZIDRIV® BITS - FOR IMPACT WRENCHES  
EMBOUS 1/4"E POZIDRIV® - POUR VISSEUSE À CHOCS  
PUNTAS DE 1/4"E POZIDRIV® - PARA ATORNILLADORES DE IMPACTO

58/60 HRC

**EASYPACK** | sacchetto PVC con Euro-hole • PVC bags with Euro-hole



	L mm	PCS.	COD.	€ cad./each
<b>PZ1</b>	50	5	61221005	3,250
<b>PZ2</b>	50	5	61221010	3,250
<b>PZ3</b>	50	5	61221015	3,250

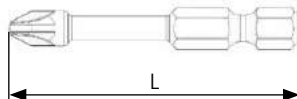

**SELPACK**  
2 pcs.

	L mm	COD.	€ box
<b>PZ1</b>	50	61221005002	7,820
<b>PZ2</b>	50	61221010002	7,820
<b>PZ3</b>	50	61221015002	7,820



**MINIBOX**  
5 pcs.

	L mm	COD.	€ box
<b>PZ1</b>	50	61221005005	17,100
<b>PZ2</b>	50	61221010005	17,100
<b>PZ3</b>	50	61221015005	17,100

**61230****TX PULSAR®**

INSERTI 1/4"C PER VITI TORX® - PER AVVITATORI A MASSA BATTENTE  
 1/4"C BITS FOR TORX® SCREWS - FOR IMPACT WRENCHES  
 EMBOUTS 1/4"C POUR VIS TORX® - POUR VISSEUSE À CHOCS  
 PUNTAS DE 1/4"C PARA TORNILLOS TORX® - PARA ATORNILLADORES DE IMPACTO

58/60 HRC

EASYPACK | sacchetto PVC con Euro-hole • PVC bags with Euro-hole

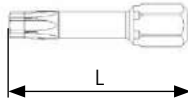

	L mm	PCS.	COD.	€ cad./each
<b>TX10</b>	30	10	61230003	2,330
<b>TX15</b>	30	10	61230004	2,330
<b>TX20</b>	30	10	61230005	2,330
<b>TX25</b>	30	10	61230010	2,330
<b>TX27</b>	30	10	61230013	2,330
<b>TX30</b>	30	10	61230015	2,330
<b>TX40</b>	30	10	61230020	2,330

	L mm	COD.	€ box
<b>TX10</b>	30	61230003002	6,000
<b>TX15</b>	30	61230004002	6,000
<b>TX20</b>	30	61230005002	6,000
<b>TX25</b>	30	61230010002	6,000
<b>TX27</b>	30	61230013002	6,000
<b>TX30</b>	30	61230015002	6,000
<b>TX40</b>	30	61230020002	6,000

	L mm	COD.	€ box
<b>TX10</b>	30	61230003010	24,400
<b>TX15</b>	30	61230004010	24,400
<b>TX20</b>	30	61230005010	24,400
<b>TX25</b>	30	61230010010	24,400
<b>TX27</b>	30	61230013010	24,400
<b>TX30</b>	30	61230015010	24,400
<b>TX40</b>	30	61230020010	24,400

SELPACK  
2 pcs.MINIBOX  
10 pcs.**61231****TX PULSAR®**

LAME 1/4"E PER VITI TORX® - PER AVVITATORI A MASSA BATTENTE  
 1/4"E POWER BITS FOR TORX® SCREWS - FOR IMPACT WRENCHES  
 EMBOUTS 1/4"E POUR VIS TORX® - POUR VISSEUSE À CHOCS  
 PUNTAS DE 1/4"E PARA TORNILLOS TORX® - PARA ATORNILLADORES DE IMPACTO

58/60 HRC

EASYPACK | sacchetto PVC con Euro-hole • PVC bags with Euro-hole

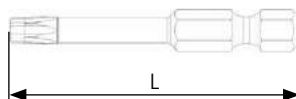

	L mm	PCS.	COD.	€ cad./each
<b>TX10</b>	50	5	61231003	4,480
<b>TX15</b>	50	5	61231004	4,480
<b>TX20</b>	50	5	61231005	4,480
<b>TX25</b>	50	5	61231010	4,480
<b>TX27</b>	50	5	61231013	4,480
<b>TX30</b>	50	5	61231015	4,480
<b>TX40</b>	50	5	61231020	4,480

	L mm	COD.	€ box
<b>TX10</b>	50	61231003002	10,300
<b>TX15</b>	50	61231004002	10,300
<b>TX20</b>	50	61231005002	10,300
<b>TX25</b>	50	61231010002	10,300
<b>TX27</b>	50	61231013002	10,300
<b>TX30</b>	50	61231015002	10,300
<b>TX40</b>	50	61231020002	10,300

	L mm	COD.	€ box
<b>TX10</b>	50	61231003005	23,500
<b>TX15</b>	50	61231004005	23,500
<b>TX20</b>	50	61231005005	23,500
<b>TX25</b>	50	61231010005	23,500
<b>TX27</b>	50	61231013005	23,500
<b>TX30</b>	50	61231015005	23,500
<b>TX40</b>	50	61231020005	23,500

SELPACK  
2 pcs.MINIBOX  
5 pcs.



# 1.1 LINEE PREMIUM

PREMIUM LINES  
LIGNES PREMIUM  
LÍNEAS PREMIUM

**61200**

HEX PULSAR®



INSERTI 1/4"C ESAGONALI - PER AVVITATORI A MASSA BATTENTE  
1/4"C HEX BITS - FOR IMPACT WRENCHES  
EMBOUTS 1/4"C 6 PANS - POUR VISSEUSE À CHOCS  
PUNTAS DE 1/4"C HEXAGONALES - PARA ATORNILLADORES DE IMPACTO

58/60 HRC

**EASYPACK** | sacchetto PVC con Euro-hole • PVC bags with Euro-hole



Ø	L mm	PCS.	COD.	€ cad./each
4	30	10	61200005	2,660
5	30	10	61200010	2,660
6	30	10	61200015	2,660

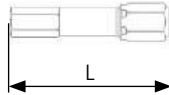

**SELPACK**  
2 pcs.

Ø	L mm	COD.	€ box
4	30	61200005002	6,650
5	30	61200010002	6,650
6	30	61200015002	6,650



**MINIBOX**  
10 pcs.

Ø	L mm	COD.	€ box
4	30	61200005010	27,900
5	30	61200010010	27,900
6	30	61200015010	27,900

**61201**

HEX PULSAR®



LAME 1/4"E ESAGONALI - PER AVVITATORI A MASSA BATTENTE  
1/4"E HEX BITS - FOR IMPACT WRENCHES  
EMBOUTS 1/4"E 6 PANS - POUR VISSEUSE À CHOCS  
PUNTAS DE 1/4"E HEXAGONALES - PARA ATORNILLADORES DE IMPACTO

58/60 HRC

**EASYPACK** | sacchetto PVC con Euro-hole • PVC bags with Euro-hole



Ø	L mm	PCS.	COD.	€ cad./each
4	50	5	61201005	4,800
5	50	5	61201010	4,800
6	50	5	61201015	4,800

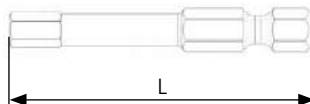

**SELPACK**  
2 pcs.

Ø	L mm	COD.	€ box
4	50	61201005002	11,000
5	50	61201010002	11,000
6	50	61201015002	11,000



**MINIBOX**  
5 pcs.

Ø	L mm	COD.	€ box
4	50	61201005005	25,200
5	50	61201010005	25,200
6	50	61201015005	25,200



## 62035 PORTAINSERTI PULSAR®



PORTAINSERTI MAGNETICO ANTI-SHOCK PER AVVITATORI A MASSA BATTENTE  
MAGNETIC BIT-HOLDER ANTI-SHOCK FOR IMPACT WRENCHES  
PORTE-EMBOUTS MAGNÉTIQUE ANTI-CHOC POUR VISSEUSE À CHOCS  
PORTA PUNTAS MAGNÉTICO ANTI-CHOQUE PARA ATORNILLADORES DE IMPACTO

**EASYPACK** | sacchetto PVC con Euro-hole • PVC bags with Euro-hole

L mm	Ø mm	PCS.	COD.	€ cad./each
60	11	5	62035005	9,910

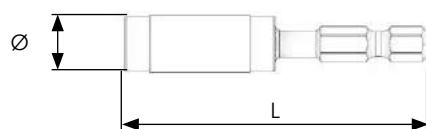

### PRESTAZIONI INSERTO + PORTAINSERTO

Bit + bit-holder performances / prestations de l'embout + porte-embout /  
prestaciones punta + portapunta

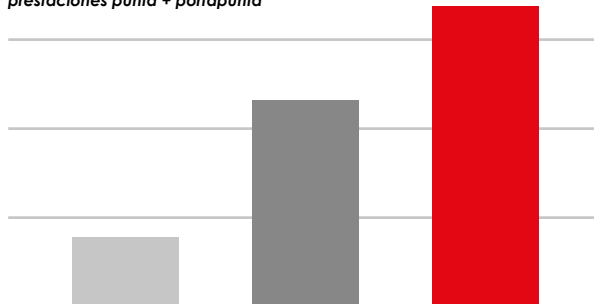

L mm	COD.	€ box
60	62035005001	11,300

**SELPACK**  
1 pc.



### FOCUS ON

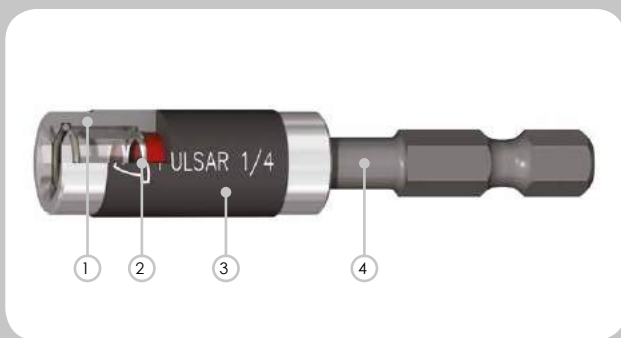

- 1 Corpo rinforzato  
Reinforced body  
Corps renforcé  
Cuerpo reforzado
- 2 Sistema antishock per la salvaguardia del magnete  
Antishock system to protect the magnet  
Système antichoc pour la protection de l'aimant  
Sistema antichoque para la protección del imán
- 3 Guaina di protezione del corpo  
Protection sheath for the body  
Gaine de protection du corps  
Vaína de protección del cuerpo
- 4 Esagono ribassato che aumenta l'angolo di coppia preservando l'insero dalla deformazione  
Low-rise hexagon that increases the torque angle, protecting the insert from deformation  
Six pans creux qui augmentent l'angle du couple en préservant l'embout de la déformation  
Hwexágono rebajado que aumenta el ángulo de par de torsión protegiendo la punta de la deformación

Apositamente studiato per lavorare con gli inserti della gamma LTI PULSAR: le esclusive geometrie costruttive fanno sì che gli inserti lavorino al meglio, garantendo una durata e prestazioni straordinarie.

Designed specifically to work with the range of LTI PULSAR bits: the exclusive construction geometries optimise the work of the bits, guaranteeing durability and outstanding performances.

Conçu spécialement pour travailler avec des embouts de la gamme LTI PULSAR : les formes permettent aux embouts de travailler au mieux, en garantissant une durée et des performances exceptionnelles.

Estudiado aposta para trabajar con los puntas de la gama LTI PULSAR: las exclusivas geometrías de fabricación hacen que los puntas trabajen con el máximo rendimiento, garantizando una duración y un rendimiento extraordinarios.

# LAB TEST





# 1.1 LINEE PREMIUM

PREMIUM LINES  
LIGNES PREMIUM  
LÍNEAS PREMIUM

66002

## MYBIT 7 ASSORTIMENTI PULSAR®

ASSORTIMENTO 7 PCS. - INSERTI + PORTAININSERTI  
7 PCS. SET - BITS + BIT-HOLDER  
JEU 7 PCS. - EMBOUTS + PORTE-EMBOUTS  
JUEGO DE 7 PCS. - PUNTAS + PORTA PUNTAS



7  
pcs.

COD. **66002200**

€ 22,200

61210



PH2  
1pc.

61220



PH3  
1pc.

61230



TX30  
1pc.

COD. **66002225**

€ 22,800

61210



PH2  
1pc.

61220



PZ2  
1pc.

61230



TX20 TX25 TX30 TX40  
1pc. 1pc. 1pc. 1pc.

COD. **66002215**

€ 21,200

61210



PH1  
1pc.

61220



PH2  
1pc.

61230



PH3  
1pc.

61240



PZ1  
1pc.

61250



PZ2  
1pc.

61260



PZ3  
1pc.

INCLUSO / INCLUDED  
INCLUDE / INCLUIDO  
COD. 62035005



66002

## DISPLAY MYBIT 7 PULSAR®

ESPOSITORE DA BANCO IN PLEXIGLASS PER 12 BIT-SETS  
12 PCS. BIT-SETS PLEXIGLASS COUNTER DISPLAY  
PRÉSENTOIR EN PLEXIGLASS POUR 12 JEUX D'EMBOUTS  
MOSTRADOR DE EXPOSICIÓN IN PLEXIGLASS PARA 12 BIT-SET

COD. **66002204**

€ 266,400

12  
pcs.



12 pcs.  
COD. 66002200

COD. **66002229**

€ 273,600



12 pcs.  
COD. 66002225

COD. **66002219**

€ 254,400



12 pcs.  
COD. 66002215



150 X 40 X 195 mm





**66007**

**MYBIT 7 POWER**  
ASSORTIMENTI PULSAR®

ASSORTIMENTO 7 PCS. - INSERTI  
7 PCS. SET - BITS  
JEU 7 PCS. - EMBOUTS  
JUEGO 7 PCS. - PUNTAS

**NEW!**



7  
pcs.

COD. **66007200**

€ 20,500

61211 ⊕ L=50mm		61221 ⊕ L=50mm		61231 ⊕ L=50mm		
PH1	PH2	PZ1	PZ2	TX25	TX30	TX40
1pc.	1pc.	1pc.	1pc.	1pc.	1pc.	1pc.

COD. **66007205**

€ 21,300

61211 ⊕ L=50mm			61221 ⊕ L=50mm		
PH1	PH2	PH3	PZ1	PZ2	PZ3
1pc.	2pcs.	1pc.	1pc.	1pc.	1pc.



100 X 120 mm





# 1.1 LINEE PREMIUM

PREMIUM LINES  
LIGNES PREMIUM  
LÍNEAS PREMIUM

**66005**

**MYBIT 10**

ASSORTIMENTI PULSAR®

ASSORTIMENTO 10 PCS. - INSERTI + PORTAINSERI  
10 PCS. SET - BITS + BIT-HOLDER  
JEU 10 PCS. - EMBOUTS + PORTE-EMBOUTS  
JUEGO DE 10 PCS. - PUNTAS + PORTA PUNTAS



10  
pcs.

COD. **66005200**

€ 24,200

61210		61220		61230		61200	
PH2	PH3	PZ2	PZ3	TX30	TX40	E5	E6
2pcs.	1pc.	1pc.	1pc.	1pc.	1pc.	1pc.	1pc.



100 X 120 mm



COD. **66005205**

€ 24,700

61210		61220		61230			
PH2	PH3	PZ2	PZ3	TX20	TX25	TX30	TX40
2pcs.	1pc.	2pcs.	1pc.	1pc.	1pc.	2pcs.	1pc.

INCLUSO / INCLUDED  
INCLUDE / INCLUIDO  
COD. 62035005



COD. **66005210**

€ 26,600

61230							
TX20	TX25	TX30	TX40	TX20	TX25	TX30	TX40
2pcs.	2pcs.	3pcs.	2pcs.	2pcs.	2pcs.	3pcs.	2pcs.

COD. **66005215**

€ 24,200

61210			61220		61230			
PH1	PH2	PH3	PZ2	PZ3	TX20	TX25	TX30	TX40
1pc.	1pc.	1pc.	1pc.	1pc.	1pc.	1pc.	1pc.	1pc.

**66005**

# DISPLAY MYBIT 10 PULSAR®

ESPOSITORE DA BANCO IN PLEXIGLASS PER 12 BIT-SETS  
 12 PCS. BIT-SETS PLEXIGLASS COUNTER DISPLAY  
 PRÉSENTOIR EN PLEXIGLAS POUR 12 JEUX D'EMBOUS  
 MOSTRADOR DE EXPOSICIÓN IN PLEXIGLASS PARA 12 BIT-SET

12  
pcs.

150 X 40 X 195 mm

COD. **66005204**

€ 290,400

12 pcs.  
COD. 66005200COD. **66005209**

€ 296,400

12 pcs.  
COD. 66005205COD. **66005214**

€ 319,200

12 pcs.  
COD. 66005210COD. **66005219**

€ 290,400

12 pcs.  
COD. 66005215



# 1.1 LINEE PREMIUM

PREMIUM LINES  
LIGNES PREMIUM  
LÍNEAS PREMIUM

66001

STORE 9

ASSORTIMENTI PULSAR®

CASSETTIERA CON 9 SCOMPARTI PER ESPOSITORE MULTISTORE  
DRAWERS WITH 9 COMPARTMENTS FOR MULTISTORE DISPLAY  
TIROIRS AVEC 9 COMPARTIMENTS POUR PRESENTOIR MULTISTORE  
9 CAJONES PARA MOSTRADOR DE EXPOSICIÓN TIPO MULTISTORE



600 X 90 X 65 mm



## MULTI STORE

COD. 66001005VC

PER DETTAGLI E COMPOSIZIONE VEDERE P. 184  
FOR DETAILS AND COMPOSITION SEE P. 184  
POUR LES DÉTAILS ET LA COMPOSITION VOIR P. 184  
PARA MÁS DETALLES Y COMPOSICIÓN VÉASE P. 184

110 pcs.

COD. **66001055**

€ 167,000

61210			61220			61230		
PH1	PH2	PH3	PZ1	PZ2	PZ3	TX25	TX30	TX40
10pcs.	20pcs.	10pcs.	10pcs.	20pcs.	10pcs.	10pcs.	10pcs.	10pcs.

140 pcs.

COD. **66001056**

€ 192,000

61210		61220		61230		
PH2	PH3	PZ2	PZ3	TX25	TX30	TX40
20pcs.	10pcs.	20pcs.	10pcs.	20pcs.	20pcs.	20pcs.

61211   
PH2  
10pcs.

61221   
PZ2  
10pcs.

**66001****MULTI BIT****ESPOSITORE INSERTI PULSAR®**

ESPOSITORE DA BANCO CON 25 SCOMPARTI  
 COUNTER DISPLAY WITH 25 COMPARTMENTS  
 PRÉSENTOIR DE COMPTOIR À 25 LOGEMENTS  
 MOSTRADOR DE EXPOSICIÓN DE 25 ALOJAMIENTOS

285  
pcs.COD. **66001305**

€ 630,000



61210  PH1 10pcs.   PH2 20pcs.   PH3 10pcs.			61220  PZ1 10pcs.   PZ2 20pcs.   PZ3 10pcs.					
61230  TX10 10pcs.   TX15 10pcs.   TX20 10pcs.   TX25 20pcs.   TX30 20pcs.   TX40 20pcs.						61200  4 5 6 5pcs. 5pcs. 5pcs.		
61211  PH1 10pcs.   PH2 10pcs.   PH3 10pcs.			61221  PZ1 10pcs.   PZ2 10pcs.   PZ3 10pcs.					
61231  TX25 10pcs.   TX30 10pcs.   TX40 10pcs.			62035005   10pcs.					

445 X 465 X 210 mm

STRUTTURA IN POLIPROPILENE ALVEOLARE AUTOPORTANTE, 25 SCOMPARTI.  
 SELF-SUPPORTING POLYPROPYLENE HONEYCOMB STRUCTURE, 25 COMPARTMENTS.  
 STRUCTURE EN POLYPROPYLÈNE ALVÉOLAIRE AUTOPORTANTE, 25 LOGEMENTS.  
 ESTRUCTURA DE POLIPROPILENO ALVEOLAR AUTOSUSTENTADA, 25 ALOJAMIENTOS.



# 1 LINEE PREMIUM

PREMIUM LINES  
LIGNES PREMIUM  
LÍNEAS PREMIUM

66001

**MULTIBOX**

ESPOSITORE MINIBOX PULSAR®

ESPOSITORE DA BANCO IN FILO METALLICO PER MINIBOX  
METAL WIRE COUNTER DISPLAY FOR MINIBOX  
PRÉSENTOIR DE COMPTOIR EN FIL MÉTALLIQUE POUR MINIBOX  
MOSTRADOR DE EXPOSICIÓN DE ALAMBRE PARA MINIBOX



508 pcs.

COD. **66001505**

€ 1'075,000

			L mm	COD.	box
10 pcs.	+	PH1	30	61210005010	2
10 pcs.	+	PH2	30	61210010010	5
10 pcs.	+	PH3	30	61210015010	2
10 pcs.	+	PZ1	30	61220005010	2
10 pcs.	+	PZ2	30	61220010010	5
10 pcs.	+	PZ3	30	61220015010	2
10 pcs.	+	TX10	30	61230003010	2
10 pcs.	+	TX15	30	61230004010	2
10 pcs.	+	TX20	30	61230005010	2
10 pcs.	+	TX25	30	61230010010	4
10 pcs.	+	TX30	30	61230015010	4
10 pcs.	+	TX40	30	61230020010	4
5 pcs.	+	PH1	50	61211005005	2
5 pcs.	+	PH2	50	61211010005	5
5 pcs.	+	PH3	50	61211015005	2
5 pcs.	+	PZ1	50	61221005005	2
5 pcs.	+	PZ2	50	61221010005	5
5 pcs.	+	PZ3	50	61221015005	2
5 pcs.	+	TX30	50	61231015005	5
5 pcs.	+	TX40	50	61231020005	5
1 pc.				62025005001	3
1 pc.				62035005001	5



370 X 545 X 220 mm

STRUTTURA IN FILO METALLICO DA BANCO ED APPENDIBILE ADATTA AD ACCOGLIERE 20 MISURE DIVERSE DI INSERTI CONFEZIONATI IN MINIBOX E DUE ARTICOLI ACCESSORI.

COUNTERTOP OR WALL-MOUNTED METAL WIRE STRUCTURE, SUITABLE FOR HOLDING BITS IN 20 DIFFERENT SIZES, MINIBOX PACKED AND TWO ACCESSORIES.

STRUCTURE EN FIL MÉTALLIQUE DE COMPTOIR ET À SUSPENDRE, ADAPTÉE POUR 20 TAILLES DIFFÉRENTES D'EMBOUTS EMBALLÉS DANS UNE MINI-BOÎTE ET DEUX ARTICLES ACCESSOIRES.

ESTRUCTURA DE HILO METÁLICO PARA MOSTRADOR QUE SE PUEDE COLGAR APTA PARA ALOJAR 20 DIFERENTES MEDIDAS DE PUNTAS PUESTOS EN MINICAJAS MÁS DOS ARTÍCULOS DE ACCESORIOS.



# FOCUS ON

## AVVITATORI IDRAULICI O AD IMPULSI

Hanno una forza di serraggio elevata ottenuta attraverso rapidissimi incrementi della pressione dell'olio. A fine serraggio viene prodotta una coppia intermittente e la tensione assiale si stabilizza. La coppia massima può essere regolata tramite la taratura della pressione dell'olio (fig. 1).

### HYDRAULIC OR PULSE WRENCHES

They have a high clamping force obtained through very rapid increases in oil pressure. An intermittent torque is produced at the end of clamping and the axial tension stabilises. The maximum torque can be adjusted by setting the oil pressure (fig. 1).

### VISSEUSES HYDRAULIQUES OU À IMPULSIONS

Elles ont une force de serrage élevée obtenue grâce à des augmentations rapides de la pression de l'huile. À la fin du serrage, un couple intermittent est produit et la tension axiale se stabilise. Le couple maximum peut être ajusté par le calibrage de la pression de l'huile (fig. 1).

### ATORNILLADORES HIDRÁULICOS O A IMPULSOS

Tienen una fuerza de cierre muy elevada, obtenida a través de incrementos de la presión del aceite muy rápidos. Al final del cierre se produce una par de torsión intermitente y la tensión axial se estabiliza. La par de torsión máxima puede regularse a través de la calibración de la presión del aceite (fig. 1).



Diagramma della coppia di serraggio in un avvitatore idraulico ad impulsi.  
Diagram of the tightening torque in a hydraulic pulse wrench.  
Diagramme du couple de serrage dans une visseuse hydraulique à impulsions.  
Diagrama de la par de torsión de cierre en un atornillador hidráulico de impulsos.

## AVVITATORI A MASSA BATTENTE

Sviluppano un'elevatissima forza di serraggio ottenuta mediante l'impatto di due parti metalliche, chiamate incudine e martello. A differenza degli avvitatori ad impulsi, la tensione assiale continua a crescere in funzione del tempo (fig 2).

### IMPACT WRENCHES

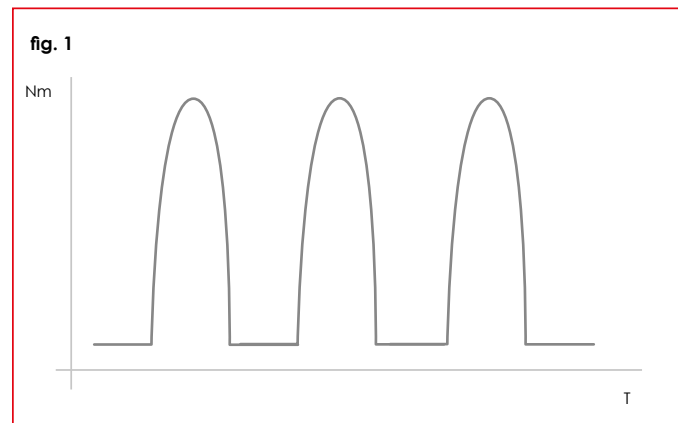
They develop a very high clamping force obtained through the impact of two metallic parts, called the anvil and hammer. Unlike pulse wrenches, the axial tension continues to grow over time (fig. 2).

### VISSEUSES À MASSE BATTANTE

Elles développent une force très élevée de serrage obtenue à l'aide d'un impact de deux pièces en métal, appelées marteau et enclume. À la différence des visseuses à impulsions, la tension axiale continue de croître en fonction du temps (fig. 2).

### ATORNILLADORES DE IMPACTO

Desarrollan una fuerza de cierre muy elevada que se obtiene a través del impacto entre dos partes metálicas, llamadas yunque y martillo. A diferencia de los atornilladores de impulsos, la tensión axial sigue creciendo dependiendo del tiempo (fig 2).



Diagramma della coppia di serraggio in un avvitatore a massa battente.  
Diagram of the tightening torque in an impact wrench.  
Diagramme du couple de serrage dans une visseuse à masse battante.  
Diagrama de la par de torsión de cierre en un atornillador percutor.

# LTI®

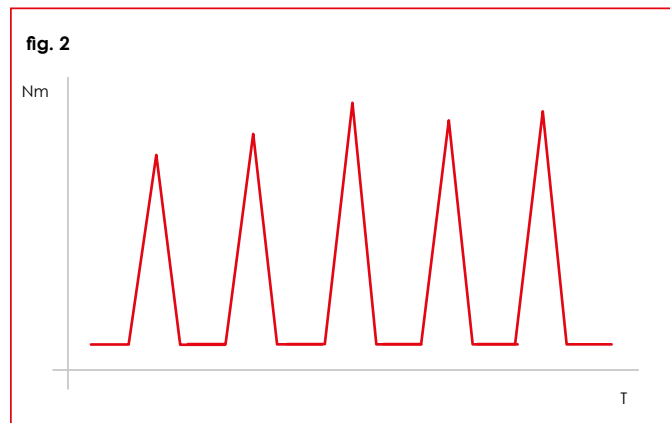

## INSERTI 1/4" TENACI RESISTENTI A COPPIE ELEVATE

1/4" heavy duty bits, high torques resistant

Embouts 1/4" tenaces et résistants aux couples élevés

Puntas de 1/4" tenaces, resistentes a elevadas par de torsión



### ANGOLO DI TORSIONE

torsion angle / angle de torsion / angulo de torsión

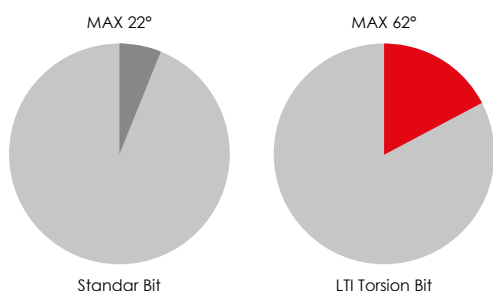

### ASSORBIMENTO COPPIA DI TORSIONE

Torque absorption / absorption du couple de torsion / absorción de la par de torsión

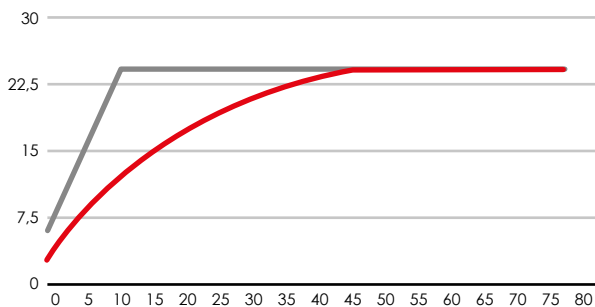

Applicazioni  
applications  
applicaciones

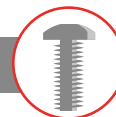

L'esclusivo design permette di disperdere lo sforzo di torsione lungo tutto l'utensile.

The exclusive design allows distributing the torsional stress along the entire length of the tool.

Le design exclusif permet de disperser la contrainte de torsion tout au long de l'outil.

El exclusivo diseño permite distribuir el esfuerzo de torsión a lo largo de todo el utensilio.



Qualità tenace, indicata per assorbire i picchi di coppia negli avvvitamenti su materiali duri.

Tough grade, suitable for absorbing torque peaks when screwing into hard materials.

Qualité tenace, indiquée pour absorber les pics de couple lors des vissages sur les matériaux durs.

Calidad tenaz, indicada para absorber los picos de par de torsión en las operaciones de atornillado sobre los metales duros.



Minimizzando i picchi si riduce l'usura, massimizzando la vita dell'utensile.

Minimisation of peaks reduces wear and maximises tool life.

La minimisation des pics permet de réduire l'usure, en maximisant la vie de l'outil.

Minimizando los picos se reduce el desgaste, maximizando la duración del utensilio.



**61058****PH TORSION®**

INSERTI 1/4" C PHILLIPS® - TENACI RESISTENTI A COPPIE ELEVATE  
 1/4" C PHILLIPS® BITS - HEAVY DUTY, RESISTANT TO HIGH TORQUES  
 EMBOUTS 1/4" C PHILLIPS® - TENACES RÉSISTANTS AUX COUPLES ÉLEVÉS  
 PUNTAS DE 1/4" C PHILLIPS® - TENACES RESISTENTES A ELEVADA TORSIÓN

58/60 HRC

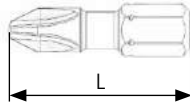
**EASYPACK** | sacchetto PVC con Euro-hole • PVC bags with Euro-hole

	L mm	PCS.	COD.	€ cad./each
<b>PH1</b>	25	10	61058005	1,050
<b>PH2</b>	25	10	61058010	1,050
<b>PH3</b>	25	10	61058015	1,050

**SELPACK**  
2 pcs.

	L mm	COD.	€ box
<b>PH1</b>	25	61058005002	3,430
<b>PH2</b>	25	61058010002	3,430
<b>PH3</b>	25	61058015002	3,430

**MINIBOX**  
10 pcs.

	L mm	COD.	€ box
<b>PH1</b>	25	61058005010	11,600
<b>PH2</b>	25	61058010010	11,600
<b>PH3</b>	25	61058015010	11,600

**61059****PH TORSION®**

LAME 1/4" E PHILLIPS® - TENACI RESISTENTI A COPPIE ELEVATE  
 1/4" E PHILLIPS® POWER BITS - HEAVY DUTY, RESISTANT TO HIGH TORQUES  
 EMBOUTS 1/4" E PHILLIPS® - TENACES RÉSISTANTES AUX COUPLES ÉLEVÉS  
 PUNTAS DE 1/4" E PHILLIPS® - TENACES RESISTENTES A ELEVADA TORSIÓN

58/60 HRC

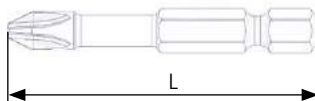
**EASYPACK** | sacchetto PVC con Euro-hole • PVC bags with Euro-hole

	L mm	PCS.	COD.	€ cad./each
<b>PH1</b>	50	5	61059005	2,820
<b>PH2</b>	50	5	61059010	2,820
<b>PH3</b>	50	5	61059015	2,820

**SELPACK**  
2 pcs.

	L mm	COD.	€ box
<b>PH1</b>	50	61059005002	6,970
<b>PH2</b>	50	61059010002	6,970
<b>PH3</b>	50	61059015002	6,970

**MINIBOX**  
5 pcs.

	L mm	COD.	€ box
<b>PH1</b>	50	61059005005	14,800
<b>PH2</b>	50	61059010005	14,800
<b>PH3</b>	50	61059015005	14,800



# 1.1 LINEE PREMIUM

PREMIUM LINES  
LIGNES PREMIUM  
LÍNEAS PREMIUM

**61083**

**PZ TORSION®**



INSERTI 1/4" C POZIDRIV® - TENACI RESISTENTI A COPPIE ELEVATE  
1/4" C POZIDRIV® BITS - HEAVY DUTY, RESISTANT TO HIGH TORQUES  
EMBOUTS 1/4" C POZIDRIV® - TENACES RÉSISTANTS AUX COUPLES ÉLEVÉS  
PUNTAS DE 1/4" C POZIDRIV® - TENACES RESISTENTES A ELEVADA TORSIÓN

58/60 HRC

**EASYPACK** | sacchetto PVC con Euro-hole • PVC bags with Euro-hole

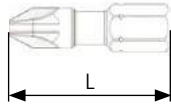

+	L mm	PCS.	COD.	€ cad./each
<b>PZ1</b>	25	10	61083005	1,050
<b>PZ2</b>	25	10	61083010	1,050
<b>PZ3</b>	25	10	61083015	1,050



**SELPACK**  
2 pcs.

+	L mm	COD.	€ box
<b>PZ1</b>	25	61083005002	3,430
<b>PZ2</b>	25	61083010002	3,430
<b>PZ3</b>	25	61083015002	3,430



**MINIBOX**  
10 pcs.

+	L mm	COD.	€ box
<b>PZ1</b>	25	61083005010	11,600
<b>PZ2</b>	25	61083010010	11,600
<b>PZ3</b>	25	61083015010	11,600

**61084**

**PZ TORSION®**



LAME 1/4" E POZIDRIV® - TENACI RESISTENTI A COPPIE ELEVATE  
1/4" E POZIDRIV® POWER BITS - HEAVY DUTY, RESISTANT TO HIGH TORQUES  
EMBOUTS 1/4" E POZIDRIV® - TENACES RÉSISTANTES AUX COUPLES ÉLEVÉS  
PUNTAS DE 1/4" E POZIDRIV® - TENACES RESISTENTES A ELEVADA TORSIÓN

58/60 HRC

**EASYPACK** | sacchetto PVC con Euro-hole • PVC bags with Euro-hole

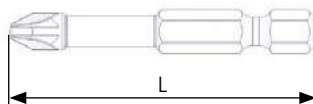

+	L mm	PCS.	COD.	€ cad./each
<b>PZ1</b>	50	5	61084005	2,820
<b>PZ2</b>	50	5	61084010	2,820
<b>PZ3</b>	50	5	61084015	2,820



**SELPACK**  
2 pcs.

+	L mm	COD.	€ box
<b>PZ1</b>	50	61084005002	6,970
<b>PZ2</b>	50	61084010002	6,970
<b>PZ3</b>	50	61084015002	6,970



**MINIBOX**  
5 pcs.

+	L mm	COD.	€ box
<b>PZ1</b>	50	61084005005	14,800
<b>PZ2</b>	50	61084010005	14,800
<b>PZ3</b>	50	61084015005	14,800

**61103 TX TORSION®**

INSERTI 1/4" C PER VITI TORX® - TENACI RESISTENTI A COPPIE ELEVATE  
 1/4" C BITS FOR TORX® SCREWS - HEAVY DUTY, RESISTANT TO HIGH TORQUES  
 EMBOUTS 1/4" C POUR VIS TORX® - TENACES RÉSISTANTS AUX COUPLES ÉLEVÉS  
 PUNTAS DE 1/4" C PARA TORNILLOS TORX® - TENACES RESISTENTES A ELEVADA TORSIÓN

58/60 HRC

EASYPACK | sacchetto PVC con Euro-hole • PVC bags with Euro-hole

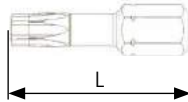

	L mm	PCS.	COD.	€ cad./each
<b>TX10</b>	25	10	61103005	1,160
<b>TX15</b>	25	10	61103010	1,160
<b>TX20</b>	25	10	61103015	1,160
<b>TX25</b>	25	10	61103020	1,160
<b>TX27</b>	25	10	61103025	1,160
<b>TX30</b>	25	10	61103030	1,160
<b>TX40</b>	25	10	61103035	1,160

	L mm	COD.	€ box
<b>TX10</b>	25	61103005002	3,650
<b>TX15</b>	25	61103010002	3,650
<b>TX20</b>	25	61103015002	3,650
<b>TX25</b>	25	61103020002	3,650
<b>TX27</b>	25	61103025002	3,650
<b>TX30</b>	25	61103030002	3,650
<b>TX40</b>	25	61103035002	3,650

SELPACK  
2 pcs.MINIBOX  
10 pcs.

	L mm	COD.	€ box
<b>TX10</b>	25	61103005010	12,100
<b>TX15</b>	25	61103010010	12,100
<b>TX20</b>	25	61103015010	12,100
<b>TX25</b>	25	61103020010	12,100
<b>TX27</b>	25	61103025010	12,100
<b>TX30</b>	25	61103030010	12,100
<b>TX40</b>	25	61103035010	12,100

**61104 TX TORSION®**

LAME 1/4" E PER VITI TORX® - TENACI RESISTENTI A COPPIE ELEVATE  
 1/4" E POWER BITS FOR TORX® SCREWS - HEAVY DUTY, RESISTANT TO HIGH TORQUES  
 EMBOUTS 1/4" E POUR VIS TORX® - TENACES RÉSISTANTES AUX COUPLES ÉLEVÉS  
 PUNTAS DE 1/4" E PARA TORNILLOS TORX® - TENACES RESISTENTES A ELEVADA TORSIÓN

58/60 HRC

EASYPACK | sacchetto PVC con Euro-hole • PVC bags with Euro-hole

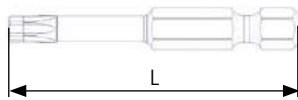

	L mm	PCS.	COD.	€ cad./each
<b>TX10</b>	50	5	61104005	4,130
<b>TX15</b>	50	5	61104010	4,130
<b>TX20</b>	50	5	61104015	4,130
<b>TX25</b>	50	5	61104020	4,130
<b>TX27</b>	50	5	61104025	4,130
<b>TX30</b>	50	5	61104030	4,130
<b>TX40</b>	50	5	61104035	4,130

	L mm	COD.	€ box
<b>TX10</b>	50	61104005002	9,590
<b>TX15</b>	50	61104010002	9,590
<b>TX20</b>	50	61104015002	9,590
<b>TX25</b>	50	61104020002	9,590
<b>TX27</b>	50	61104025002	9,590
<b>TX30</b>	50	61104030002	9,590
<b>TX40</b>	50	61104035002	9,590

SELPACK  
2 pcs.MINIBOX  
5 pcs.

	L mm	COD.	€ box
<b>TX10</b>	50	61104005005	21,500
<b>TX15</b>	50	61104010005	21,500
<b>TX20</b>	50	61104015005	21,500
<b>TX25</b>	50	61104020005	21,500
<b>TX27</b>	50	61104025005	21,500
<b>TX30</b>	50	61104030005	21,500
<b>TX40</b>	50	61104035005	21,500



# 1.1 LINEE PREMIUM

PREMIUM LINES  
LIGNES PREMIUM  
LÍNEAS PREMIUM

66002

## MYBIT 7 ASSORTIMENTI TORSION®

ASSORTIMENTO 7 PCS. - INSERTI + PORTAINSERI  
7 PCS. SET - BITS + BIT-HOLDER  
JEU 7 PCS. - EMBOUTS + PORTE-EMBOUTS  
JUEGO DE 7 PCS. - PUNTAS + PORTA PUNTAS



7  
pcs.

COD. **66002300**

€ 11,500

61058



PH1  
1pc.

PH2  
1pc.

PH3  
1pc.

61083



PZ1  
1pc.

PZ2  
1pc.

PZ3  
1pc.

COD. **66002305**

€ 12,000

61103



TX10  
1pc.

TX15  
1pc.

TX20  
1pc.

TX25  
1pc.

TX30  
1pc.

TX40  
1pc.

COD. **66002310**

€ 11,600

61058



PH2  
1pc.

PH3  
1pc.

61083



PZ2  
1pc.

PZ3  
1pc.

61103



TX25  
1pc.

TX30  
1pc.

INCLUSO / INCLUDED  
INCLUSE / INCLUIDO

COD. 62013005



100 X 120 mm

66002

## DISPLAY MYBIT 7 TORSION®

ESPOSITORE DA BANCO IN PLEXIGLASS PER 12 BIT-SETS  
12 PCS. BIT-SETS PLEXIGLASS COUNTER DISPLAY  
PRÉSENTOIR EN PLEXIGLASS POUR 12 JEUX D'EMBOUTS  
MOSTRADOR DE EXPOSICIÓN IN PLEXIGLASS PARA 12 BIT-SET

COD. **66002304**

€ 138,000

12  
pcs.



12 pcs.  
COD. 66002300

COD. **66002309**

€ 144,000



12 pcs.  
COD. 66002305

COD. **66002314**

€ 139,200



12 pcs.  
COD. 66002310



150 X 40 X 195 mm



66007

# MYBIT 7 POWER ASSORTIMENTI TORSION®

ASSORTIMENTO 7 PCS. - INSERTI  
7 PCS. SET - BITS  
JEU 7 PCS. - EMBOUTS  
JUEGO 7 PCS. - PUNTAS

**NEW!**



7  
pcs.

COD. **66007300**

€ 17,800

61059 ⊕ L=50mm		61084 ⊕ L=50mm		61104 ⊕ L=50mm		
PH1 1pc.	PH2 1pc.	PZ1 1pc.	PZ2 1pc.	TX25 1pc.	TX30 1pc.	TX40 1pc.

COD. **66007305**

€ 23,000

61059 ⊕ L=50mm			61084 ⊕ L=50mm		
PH1 1pc.	PH2 2pcs.	PH3 1pc.	PZ1 1pc.	PZ2 1pc.	PZ3 1pc.



100 X 120 mm





# 1. LINEE PREMIUM

PREMIUM LINES  
LIGNES PREMIUM  
LÍNEAS PREMIUM

**66005**

**MYBIT 10**

ASSORTIMENTI TORSION®

ASSORTIMENTO 10 PCS. - INSERTI + PORTAINSERI  
10 PCS. SET - BITS + BIT-HOLDER  
JEU 10 PCS. - EMBOUTS + PORTE-EMBOUTS  
JUEGO DE 10 PCS. - PUNTAS + PORTA PUNTAS

COD. **66005300**

€ 14,000



10 pcs.

61058			61083			61103		
PH1	PH2	PH3	PZ1	PZ2	PZ3	TX20	TX25	TX30
1pc.	1pc.	1pc.	1pc.	1pc.	1pc.	1pc.	1pc.	1pc.

COD. **66005305**

€ 14,500

61058		61083		61103	
PH2	PH3	PZ2	PZ3	TX25	TX30
2pcs.	1pc.	2pcs.	1pc.	1pc.	2pcs.

COD. **66005310**

€ 14,800

61058		61083		61103			
PH2	PH3	PZ2	PZ3	TX15	TX20	TX25	TX30
2pcs.	1pc.	1pc.	1pc.	1pc.	1pc.	1pc.	1pc.

INCLUSO / INCLUDED  
INCLUSE / INCLUIDO

COD. 62013005



**66005**

**DISPLAY MYBIT 10**  
TORSION®

ESPOSITORE DA BANCO IN PLEXIGLASS PER 12 BIT-SETS  
12 PCS. BIT-SETS PLEXIGLASS COUNTER DISPLAY  
PRÉSENTOIR EN PLEXIGLASS POUR 12 JEUX D'EMBOUTS  
MOSTRADOR DE EXPOSICIÓN IN PLEXIGLASS PARA 12 BIT-SET

COD. **66005304**

€ 168,000

12 pcs.



12 pcs.  
COD. 66005300

COD. **66005309**

€ 174,000



12 pcs.  
COD. 66005305

COD. **66005314**

€ 177,600



12 pcs.  
COD. 66005310



150 X 40 X 195 mm



**66006** **MYBIT 15**  
ASSORTIMENTI TORSION®

ASSORTIMENTO 15 PCS. - INSERTI + PORTAINSERI  
15 PCS. SET - BITS + BIT-HOLDER  
JEU 15 PCS. - EMBOUTS + PORTE-EMBOUTS  
JUEGO DE 15 PCS. - PUNTAS + PORTA PUNTAS



15 pcs.

COD. **66006305**  
€ 19,800

61058			61083		
PH1 1pc.	PH2 1pc.	PH3 1pc.	PZ1 1pc.	PZ2 1pc.	PZ3 1pc.
61103					
TX10 1pc.	TX15 1pc.	TX20 1pc.	TX25 1pc.	TX30 1pc.	TX40 1pc.
61059			61084		
PH2 1pc.			PZ2 1pc.		



100 X 167 mm



INCLUSO / INCLUDED  
INCLUDE / INCLUIDO  
COD. 62013005



**66006** **DISPLAY MYBIT 15**  
TORSION®

ESPOSITORE DA BANCO IN PLEXIGLASS PER 12 BIT-SETS  
12 PCS. BIT-SETS PLEXIGLASS COUNTER DISPLAY  
PRÉSENTOIR EN PLEXIGLAS POUR 12 JEUX D'EMBOUTS  
MOSTRADOR DE EXPOSICIÓN IN PLEXIGLASS PARA 12 BIT-SET



12 pcs.

COD. **66006309**  
€ 237,600



12 pcs.  
COD. 66006305

185 X 40 X 195 mm



# 1.1 LINEE PREMIUM

PREMIUM LINES  
LIGNES PREMIUM  
LÍNEAS PREMIUM

**66006**

## MYBIT 14 TORSION® CON CRICCHETTO

ASSORTIMENTO 14 PCS. TORSION® / CRICCHETTO  
14 PCS. SET - BITS + BIT HOLDER AND RATCHET  
JEU 14 PCS. - EMBOUTS + PORTE-EMBOUTS  
JUEGO DE 14 PCS. - PUNTAS + PORTA PUNTAS

**NEW!**

14  
pcs.



100 X 170 mm



COD. **66006505**

€ 30,300

61058			61069		
PH1	PH2	PH3	PZ1	PZ2	PZ3
1pc.	1pc.	1pc.	1pc.	1pc.	1pc.

61103					
TX10	TX15	TX20	TX25	TX30	TX40
1pc.	1pc.	1pc.	1pc.	1pc.	1pc.

INCLUSO / INCLUDED  
INCLUDE / INCLUIDO

COD. 62013005



COD. 64221030



**66010**

## ASSORTIMENTI TORSION®

ASSORTIMENTO 31 PCS. - INSERTI + PORTAINSERI  
31 PCS. SET - BITS + BIT-HOLDER  
JEU 31 PCS. - EMBOUTS + PORTE-EMBOUTS  
JUEGO DE 31 PCS. - PUNTAS + PORTA PUNTAS

31  
pcs.



80 X 115 X 30 mm

COD. **66010030**

€ 34,700

61058			61083		
PH1	PH2	PH3	PZ1	PZ2	PZ3
2pcs.	4pcs.	3pcs.	2pcs.	4pcs.	3pcs.

61103			
TX20	TX25	TX30	TX40
3pcs.	3pcs.	3pcs.	3pcs.

INCLUSO / INCLUDED  
INCLUDE / INCLUIDO  
COD. 62013005







**66001**

**STORE 9**  
ASSORTIMENTI TORSION®

CASSETTIERA CON 9 SCOMPARTI PER ESPOSITORE MULTISTORE  
DRAWERS WITH 9 COMPARTMENTS FOR MULTISTORE DISPLAY  
TIROIRS AVEC 9 COMPARTIMENTS POUR PRESENTOIR MULTISTORE  
9 CAJONES PARA MOSTRADOR DE EXPOSICIÓN TIPO MULTISTORE

165  
pcs.



600 X 90 X 65 mm



**MULTI STORE**

COD. 66001005VC

PER DETTAGLI E COMPOSIZIONE VEDERE P. 184  
FOR DETAILS AND COMPOSITION SEE P. 184  
POUR LES DÉTAILS ET LA COMPOSITION VOIR P. 184  
PARA MÁS DETALLES Y COMPOSICIÓN VÉASE P. 184

COD. **66001060**

€ 138,000

61058			61083			61103		
PH1	PH2	PH3	PZ1	PZ2	PZ3	TX25	TX30	TX40
10pcs.	30pcs.	20pcs.	10pcs.	30pcs.	20pcs.	15pcs.	15pcs.	15pcs.

COD. **66001061**

€ 164,000

61058		61083		61103		
PH1	PH2	PZ1	PZ2	TX25	TX30	TX40
20pcs.	30pcs.	20pcs.	30pcs.	15pcs.	15pcs.	15pcs.

61059		61084	
PH2		PZ2	
10pcs.		10pcs.	



# 1.1 LINEE PREMIUM

PREMIUM LINES  
LIGNES PREMIUM  
LÍNEAS PREMIUM

66001

**MULTI BIT**

ESPOSITORE INSERTI TORSION®

ESPOSITORE DA BANCO CON 25 SCOMPARTI  
COUNTER DISPLAY WITH 25 COMPARTMENTS  
PRÉSENTOIR DE COMPTOIR À 25 LOGEMENTS  
MOSTRADOR DE EXPOSICIÓN DE 25 ALOJAMIENTOS

310  
pcs.



COD. **66001310**

€ 524,000

<p>61058 </p> <p>PH1 10pcs.   PH2 30pcs.   PH3 10pcs.</p>			<p>61083 </p> <p>PZ1 10pcs.   PZ2 20pcs.   PZ3 10pcs.</p>		
<p>61103 </p> <p>TX10 10pcs.   TX15 10pcs.   TX20 10pcs.   TX25 20pcs.   TX30 20pcs.   TX40 20pcs.</p>					
<p>61059 </p> <p>PH1 10pcs.   PH2 10pcs.   PH3 10pcs.</p>			<p>61084 </p> <p>PZ1 10pcs.   PZ2 10pcs.   PZ3 10pcs.</p>		
<p>61104 </p> <p>TX10 10pcs.   TX15 10pcs.   TX20 10pcs.   TX25 10pcs.   TX30 10pcs.   TX40 10pcs.</p>					<p>62016005 </p> <p> </p> <p>10pcs.</p>

445 X 465 X 210 mm

STRUTTURA IN POLIPROPILENE ALVEOLARE AUTOPORTANTE, 25 SCOMPARTI.  
SELF-SUPPORTING POLYPROPYLENE HONEYCOMB STRUCTURE, 25 COMPARTMENTS.  
STRUCTURE EN POLYPROPYLÈNE ALVÉOLAIRE AUTOPORTANTE, 25 LOGEMENTS.  
ESTRUCTURA DE POLIPROPILENO ALVEOLAR AUTOSUSTENTADA, 25 ALOJAMIENTOS.

**66001****MULTI BOX**  
ESPOSITORE MINIBOX TORSION®ESPOSITORE DA BANCO IN FILO METALLICO PER MINIBOX  
METAL WIRE COUNTER DISPLAY FOR MINIBOX  
PRÉSENTOIR DE COMPTOIR EN FIL MÉTALLIQUE POUR MINIBOX  
MOSTRADOR DE EXPOSICIÓN DE ALAMBRE PARA MINIBOX**568**  
pcs.COD. **66001510****€ 792,000**

			L mm	COD.	box
10 pcs.		<b>PH1</b>	25	61058005010	4
10 pcs.		<b>PH2</b>	25	61058010010	5
10 pcs.		<b>PH3</b>	25	61058015010	4
10 pcs.		<b>PZ1</b>	25	61083005010	4
10 pcs.		<b>PZ2</b>	25	61083010010	5
10 pcs.		<b>PZ3</b>	25	61083015010	4
10 pcs.		<b>TX15</b>	25	61103010010	3
10 pcs.		<b>TX20</b>	25	61103015010	3
10 pcs.		<b>TX25</b>	25	61103020010	4
10 pcs.		<b>TX30</b>	25	61103030010	4
10 pcs.		<b>TX40</b>	25	61103035010	4
5 pcs.		<b>PH1</b>	50	61059005005	3
5 pcs.		<b>PH2</b>	50	61059010005	3
5 pcs.		<b>PH3</b>	50	61059015005	3
5 pcs.		<b>PZ1</b>	50	61084005005	3
5 pcs.		<b>PZ2</b>	50	61084010005	3
5 pcs.		<b>PZ3</b>	50	61084015005	3
5 pcs.		<b>TX25</b>	50	61104020005	2
5 pcs.		<b>TX30</b>	50	61104030005	2
5 pcs.		<b>TX40</b>	50	61104035005	2
1 pc.				62029005	3
1 pc.				62019015001	5



370 X 545 X 220 mm

STRUTTURA IN FILO METALLICO DA BANCO ED APPENDIBILE ADATTA AD ACCOGLIERE 20 MISURE DIVERSE DI INSERTI CONFEZIONATI IN MINIBOX E DUE ARTICOLI ACCESSORI.

COUNTERTOP OR WALL-MOUNTED METAL WIRE STRUCTURE, SUITABLE FOR HOLDING BITS IN 20 DIFFERENT SIZES, MINIBOX PACKED AND TWO ACCESSORIES.

STRUCTURE EN FIL MÉTALLIQUE DE COMPTOIR ET À SUSPENDRE, ADAPTÉE POUR 20 TAILLES DIFFÉRENTES D'EMBOÛTS EMBALLÉS DANS UNE MINI-BOÎTE ET DEUX ARTICLES ACCESSOIRES.

ESTRUCTURA DE HILO METÁLICO PARA MOSTRADOR QUE SE PUEDE COLGAR APTA PARA ALOJAR 20 DIFERENTES MEDIDAS DE PUNTAS PUESTOS EN MINICAJAS MÁS DOS ARTÍCULOS DE ACCESORIOS.

## INSERTI 1/4" RESISTENTI A COPPIE ELEVATE EXTRA HARD

1/4" extra-hard bits torques resistant

Embouts 1/4" extra hard résistants aux couples élevés

Puntas de 1/4" extra hard resistentes a elevadas par de torsión



### RAPPORTO DUREZZA-TENACITÀ

Hardness-toughness ratio / rapport dureté-ténacité / relación dureza-tenacidad

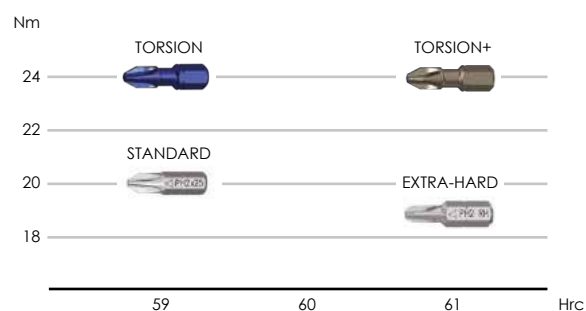

### RESISTENZA ALL'USURA

Wear resistance / résistance à l'usure / resistencia al desgaste

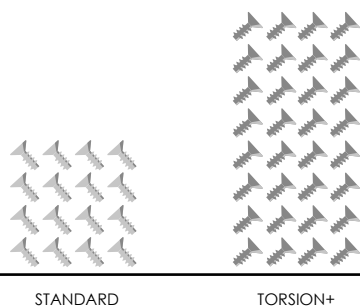

Applicazioni  
applications  
aplicaciones

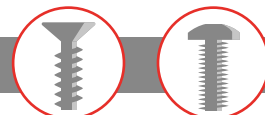

Perfetto rapporto durezza/tenacità, TORSION+ raggiunge elevatissimi valori di resistenza alla torsione.

Perfect hardness/toughness ratio, TORSION+ reaches very high values of torsional stiffness.

Rapport parfait dureté/ténacité, TORSION+ atteint des valeurs très élevées de résistance à la torsion.

Perfecta relación entre dureza /tenacidad, TORSIÓN+ alcanza elevadísimos valores de resistencia a la torsión.



Ottima resistenza all'usura: la geometria dell'impronta rimane costante anche dopo moltissimi cicli di avvitatura.

Excellent wear resistance: the geometry of the tip remains constant even after numerous screwing cycles.

Excellente résistance à l'usure : la forme de l'empreinte est constante, même après plusieurs cycles de vissage.

Óptima resistencia al desgaste: la geometría de la huella permanece constante incluso después de muchísimos ciclos de atornillado.



Ideali per applicazioni intensive, anche nel settore industriale, dove l'efficienza dell'utensile deve rimanere costante per lungo tempo.

Ideal for heavy-duty applications, even in the industrial sector where tool efficiency must remain constant over a long time.

Idéales pour des applications intensives, même dans le secteur industriel, où l'efficacité de l'outil doit rester constante pendant sur longue période.

Ideal para aplicaciones intensas, incluso en el sector industrial, donde la eficiencia del utensilio tiene que permanecer constante por un largo tiempo.

**61250****PH TORSION+**

INSERTI 1/4"C PHILLIPS® - EXTRA DURI, RESISTENTI A COPPIE ELEVATE  
 1/4"C PHILLIPS® BITS - EXTRA HARD, RESISTANT TO HIGH TORQUES  
 EMBOUTS 1/4"C PHILLIPS® - EXTRA HARD, RÉSISTANTS AUX COUPLES ÉLEVÉS  
 PUNTAS DE 1/4"C PHILLIPS® - EXTRA DUROS, RESISTENTES A ELEVADA TORSIÓN

60/62 HRC

EASYPACK | sacchetto PVC con Euro-hole • PVC bags with Euro-hole

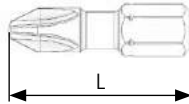

	L mm	PCS.	COD.	€ cad./each
PH1	25	10	61250005	1,320
PH2	25	10	61250010	1,320
PH3	25	10	61250015	1,320



	L mm	COD.	€ box
PH1	25	61250005002	3,970
PH2	25	61250010002	3,970
PH3	25	61250015002	3,970

SELFPACK  
2 pcs.

	L mm	COD.	€ box
PH1	25	61250005010	13,800
PH2	25	61250010010	13,800
PH3	25	61250015010	13,800

MINIBOX  
10 pcs.**61251****PH TORSION+**

LAME 1/4"E PHILLIPS® - EXTRA DURI, RESISTENTI A COPPIE ELEVATE  
 1/4"E PHILLIPS® POWER BITS - EXTRA HARD, RESISTANT TO HIGH TORQUES  
 EMBOUTS 1/4"E PHILLIPS® - EXTRA HARD, RÉSISTANTS AUX COUPLES ÉLEVÉS  
 PUNTAS DE 1/4"E PHILLIPS® - EXTRA DUROS, RESISTENTES A ELEVADA TORSIÓN

60/62 HRC

EASYPACK | sacchetto PVC con Euro-hole • PVC bags with Euro-hole

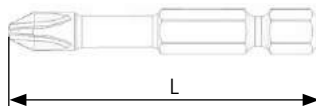

	L mm	PCS.	COD.	€ cad./each
PH1	50	5	61251005	3,060
PH2	50	5	61251010	3,060
PH3	50	5	61251015	3,060



	L mm	COD.	€ box
PH1	50	61251005002	7,450
PH2	50	61251010002	7,450
PH3	50	61251015002	7,450

SELFPACK  
2 pcs.

	L mm	COD.	€ box
PH1	50	61251005005	16,100
PH2	50	61251010005	16,100
PH3	50	61251015005	16,100

MINIBOX  
5 pcs.



# 1.1 LINEE PREMIUM

PREMIUM LINES  
LIGNES PREMIUM  
LÍNEAS PREMIUM

**61260**

**PZ TORSION+**



INSERTI 1/4" C POZIDRIV® - EXTRA DURI, RESISTENTI A COPPIE ELEVATE  
1/4" C POZIDRIV® BITS - EXTRA HARD, RESISTANT TO HIGH TORQUES  
EMBOUS 1/4" C POZIDRIV® - EXTRA HARD, RÉSISTANTS AUX COUPLES ÉLEVÉS  
PUNTAS DE 1/4" C POZIDRIV® - EXTRA DUROS, RESISTENTES A ELEVADA TORSIÓN

60/62 HRC

**EASYPACK** | sacchetto PVC con Euro-hole • PVC bags with Euro-hole

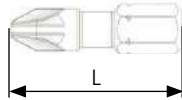

+	L mm	PCS.	COD.	€ cad./each
PZ1	25	10	61260005	1,320
PZ2	25	10	61260010	1,320
PZ3	25	10	61260015	1,320



+	L mm	COD.	€ box
PZ1	25	61260005002	3,970
PZ2	25	61260010002	3,970
PZ3	25	61260015002	3,970

**SELPACK**  
2 pcs.



+	L mm	COD.	€ box
PZ1	25	61260005010	13,800
PZ2	25	61260010010	13,800
PZ3	25	61260015010	13,800

**MINIBOX**  
10 pcs.

**61261**

**PZ TORSION+**



LAME 1/4" E POZIDRIV® - EXTRA DURI, RESISTENTI A COPPIE ELEVATE  
1/4" E POZIDRIV® POWER BITS - EXTRA HARD, RESISTANT TO HIGH TORQUES  
EMBOUS 1/4" E POZIDRIV® - EXTRA HARD, RÉSISTANTS AUX COUPLES ÉLEVÉS  
PUNTAS DE 1/4" E POZIDRIV® - EXTRA DUROS, RESISTENTES A ELEVADA TORSIÓN

60/62 HRC

**EASYPACK** | sacchetto PVC con Euro-hole • PVC bags with Euro-hole

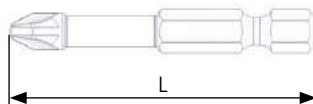

+	L mm	PCS.	COD.	€ cad./each
PZ1	50	5	61261005	3,060
PZ2	50	5	61261010	3,060
PZ3	50	5	61261015	3,060



+	L mm	COD.	€ box
PZ1	50	61261005002	7,450
PZ2	50	61261010002	7,450
PZ3	50	61261015002	7,450

**SELPACK**  
2 pcs.



+	L mm	COD.	€ box
PZ1	50	61261005005	16,100
PZ2	50	61261010005	16,100
PZ3	50	61261015005	16,100

**MINIBOX**  
5 pcs.

**61270****TX TORSION+**

INSERTI 1/4" C PER VITI TORX® - EXTRA DURI, RESISTENTI A COPPIE ELEVATE  
 1/4" C BITS FOR TORX® SCREWS - EXTRA HARD, RESISTANT TO HIGH TORQUES  
 EMBOUTS 1/4" C POUR VIS TORX® - EXTRA HARD, RÉSISTANTS AUX COUPLES ÉLEVÉS  
 PUNTAS DE 1/4" C PARA TORNILLOS TORX® - EXTRA DUROS, RESISTENTES A ELEVADA TORSIÓN

60/62 HRC

EASYPACK | sacchetto PVC con Euro-hole • PVC bags with Euro-hole

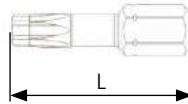

	L mm	PCS.	COD.	€ cad./each
<b>TX10</b>	25	10	61270005	1,580
<b>TX15</b>	25	10	61270010	1,580
<b>TX20</b>	25	10	61270015	1,580
<b>TX25</b>	25	10	61270020	1,580
<b>TX27</b>	25	10	61270025	1,580
<b>TX30</b>	25	10	61270030	1,580
<b>TX40</b>	25	10	61270035	1,580

	L mm	COD.	€ box
<b>TX10</b>	25	61270005002	4,500
<b>TX15</b>	25	61270010002	4,500
<b>TX20</b>	25	61270015002	4,500
<b>TX25</b>	25	61270020002	4,500
<b>TX27</b>	25	61270025002	4,500
<b>TX30</b>	25	61270030002	4,500
<b>TX40</b>	25	61270035002	4,500

	L mm	COD.	€ box
<b>TX10</b>	25	61270005010	16,600
<b>TX15</b>	25	61270010010	16,600
<b>TX20</b>	25	61270015010	16,600
<b>TX25</b>	25	61270020010	16,600
<b>TX27</b>	25	61270025010	16,600
<b>TX30</b>	25	61270030010	16,600
<b>TX40</b>	25	61270035010	16,600

SELPACK  
2 pcs.MINIBOX  
10 pcs.**61271****TX TORSION+**

LAME 1/4" E PER VITI TORX® - EXTRA DURI, RESISTENTI A COPPIE ELEVATE  
 1/4" E POWER BITS FOR TORX® SCREWS - EXTRA HARD, RESISTANT TO HIGH TORQUES  
 EMBOUTS 1/4" E POUR VIS TORX® - EXTRA HARD, RÉSISTANTS AUX COUPLES ÉLEVÉS  
 PUNTAS DE 1/4" E PARA TORNILLOS TORX® - EXTRA DUROS, RESISTENTES A ELEVADA TORSIÓN

60/62 HRC

EASYPACK | sacchetto PVC con Euro-hole • PVC bags with Euro-hole

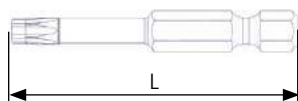

	L mm	PCS.	COD.	€ cad./each
<b>TX10</b>	50	5	61271005	4,450
<b>TX15</b>	50	5	61271010	4,450
<b>TX20</b>	50	5	61271015	4,450
<b>TX25</b>	50	5	61271020	4,450
<b>TX27</b>	50	5	61271025	4,450
<b>TX30</b>	50	5	61271030	4,450
<b>TX40</b>	50	5	61271035	4,450

	L mm	COD.	€ box
<b>TX10</b>	50	61271005002	10,300
<b>TX15</b>	50	61271010002	10,300
<b>TX20</b>	50	61271015002	10,300
<b>TX25</b>	50	61271020002	10,300
<b>TX27</b>	50	61271025002	10,300
<b>TX30</b>	50	61271030002	10,300
<b>TX40</b>	50	61271035002	10,300

	L mm	COD.	€ box
<b>TX10</b>	50	61271005005	23,400
<b>TX15</b>	50	61271010005	23,400
<b>TX20</b>	50	61271015005	23,400
<b>TX25</b>	50	61271020005	23,400
<b>TX27</b>	50	61271025005	23,400
<b>TX30</b>	50	61271030005	23,400
<b>TX40</b>	50	61271035005	23,400

SELPACK  
2 pcs.MINIBOX  
5 pcs.



# 1.1 LINEE PREMIUM

PREMIUM LINES  
LIGNES PREMIUM  
LÍNEAS PREMIUM

66002

MYBIT 7

ASSORTIMENTI TORSION+

ASSORTIMENTO 7 PCS. - INSERTI + PORTAINSERI  
7 PCS. SET - BITS + BIT-HOLDER  
JEU 7 PCS. - EMBOUTS + PORTE-EMBOUTS  
JUEGO DE 7 PCS. - PUNTAS + PORTA PUNTAS



7 pcs.



100 X 120 mm



INCLUSO / INCLUDED  
INCLUSE / INCLUIDO  
COD. 62013005



COD. **66002350**  
€ 12,800

61250



PH1  
1pc.

PH2  
1pc.

PH3  
1pc.

PZ1  
1pc.

PZ2  
1pc.

PZ3  
1pc.

COD. **66002355**  
€ 14,400

61270



TX10  
1pc.

TX15  
1pc.

TX20  
1pc.

TX25  
1pc.

TX30  
1pc.

TX40  
1pc.

COD. **66002360**  
€ 13,300

61250



PH1  
1pc.

PH2  
1pc.

61260



PZ1  
1pc.

PZ2  
1pc.

61270



TX20  
1pc.

TX25  
1pc.

66002

DISPLAY MYBIT 7  
TORSION+

ESPOSITORE DA BANCO IN PLEXIGLASS PER 12 BIT-SETS  
12 PCS. BIT-SETS PLEXIGLASS COUNTER DISPLAY  
PRÉSENTOIR EN PLEXIGLASS POUR 12 JEUX D'EMBOUTS  
MOSTRADOR DE EXPOSICIÓN IN PLEXIGLASS PARA 12 BIT-SET



12 pcs.

150 X 40 X 195 mm

COD. **66002354**  
€ 153,600



12 pcs.  
COD. 66002350

COD. **66002359**  
€ 172,800



12 pcs.  
COD. 66002355

COD. **66002364**  
€ 159,600



12 pcs.  
COD. 66002360





66007

MYBIT 7 POWER

ASSORTIMENTI TORSION+

ASSORTIMENTO 7 PCS. - INSERTI  
7 PCS. SET - BITS  
JEU 7 PCS. - EMBOUTS  
JUEGO 7 PCS. - PUNTAS

NEW!



7 pcs.

COD. 66007350

€ 19,300

61251  L=50mm		61261  L=50mm		61271  L=50mm		
PH1 1pc.	PH2 1pc.	PZ1 1pc.	PZ2 1pc.	TX25 1pc.	TX30 1pc.	TX40 1pc.

COD. 66007355

€ 26,100

61251  L=50mm			61261  L=50mm		
PH1 1pc.	PH2 2pcs.	PH3 1pc.	PZ1 1pc.	PZ2 1pc.	PZ3 1pc.



100 X 120 mm





# 1. LINEE PREMIUM

PREMIUM LINES  
LIGNES PREMIUM  
LÍNEAS PREMIUM

66005

MYBIT 10

ASSORTIMENTI TORSION+

ASSORTIMENTO 10 PCS. - INSERTI + PORTAINSERI  
10 PCS. SET - BITS + BIT-HOLDER  
JEU 10 PCS. - EMBOUTS + PORTE-EMBOUTS  
JUEGO DE 10 PCS. - PUNTAS + PORTA PUNTAS



10 pcs.



100 X 120 mm



INCLUSO / INCLUDED  
INCLUSE / INCLUIDO  
COD. 62013005



COD. 66005350

€ 17,200

61250			61260			61270		
PH1	PH2	PH3	PZ1	PZ2	PZ3	TX20	TX25	TX30
1pc.	1pc.	1pc.	1pc.	1pc.	1pc.	1pc.	1pc.	1pc.

COD. 66005355

€ 17,200

61250		61260		61270	
PH2	PH3	PZ2	PZ3	TX30	TX40
2pcs.	1pc.	2pcs.	1pc.	1pc.	2pcs.

COD. 66005360

€ 17,400

61250		61260		61270			
PH2	PH3	PZ2	PZ3	TX20	TX25	TX30	TX40
2pcs.	1pc.	1pc.	1pc.	1pc.	1pc.	1pc.	1pc.

66005

DISPLAY MYBIT 10  
TORSION+

ESPOSITORE DA BANCO IN PLEXIGLASS PER 12 BIT-SETS  
12 PCS. BIT-SETS PLEXIGLASS COUNTER DISPLAY  
PRÉSENTOIR EN PLEXIGLASS POUR 12 JEUX D'EMBOUTS  
MOSTRADOR DE EXPOSICIÓN IN PLEXIGLASS PARA 12 BIT-SET



12 pcs.

150 X 40 X 195 mm

COD. 66005354

€ 206,400



12 pcs.  
COD. 66005350

COD. 66005359

€ 206,400



12 pcs.  
COD. 66005355

COD. 66005364

€ 208,800



12 pcs.  
COD. 66005360

**66006****MYBIT 15**

ASSORTIMENTI TORSION+

ASSORTIMENTO 15 PCS. - INSERTI + PORTAINSERI  
 15 PCS. SET - BITS + BIT-HOLDER  
 JEU 15 PCS. - EMBOUTS + PORTE-EMBOUTS  
 JUEGO DE 15 PCS. - PUNTAS + PORTA PUNTAS

COD. **66006310**

€ 24,700

15  
pcs.

100 X 167 mm



INCLUSO / INCLUDED  
 INCLUDE / INCLUIDO

COD. 62013005



61250			61260		
PH1 1pc.	PH2 1pc.	PH3 1pc.	PZ1 1pc.	PZ2 1pc.	PZ3 1pc.
61270					
TX10 1pc.	TX15 1pc.	TX20 1pc.	TX25 1pc.	TX30 1pc.	TX40 1pc.
61251			61261		
PH2 1pc.			PZ2 1pc.		

**66006****DISPLAY MYBIT 15**  
TORSION+

ESPOSITORE DA BANCO IN PLEXIGLASS PER 12 BIT-SETS  
 12 PCS. BIT-SETS PLEXIGLASS COUNTER DISPLAY  
 PRÉSENTOIR EN PLEXIGLAS POUR 12 JEUX D'EMBOUTS  
 MOSTRADOR DE EXPOSICIÓN IN PLEXIGLASS PARA 12 BIT-SET

COD. **66006314**

€ 296,40

12  
pcs.12 pcs.  
COD. 66006310

185 X 40 X 195 mm



# 1.1 LINEE PREMIUM

PREMIUM LINES  
LIGNES PREMIUM  
LÍNEAS PREMIUM

**66006**

## MYBIT 14 TORSION+ CON CRICCHETTO

ASSORTIMENTO 14 PCS. TORSION+ / CRICCHETTO  
14 PCS. SET - BITS + BIT HOLDER AND RATCHET  
JEU 14 PCS. - EMBOUTS + PORTE-EMBOUTS  
JUEGO DE 14 PCS. - PUNTAS + PORTA PUNTAS

**NEW!**

14  
pcs.



100 X 170 mm



COD. **66006510**

€ 33,300

61250			61260		
PH1	PH2	PH3	PZ1	PZ2	PZ3
1pc.	1pc.	1pc.	1pc.	1pc.	1pc.

61270					
TX10	TX15	TX20	TX25	TX30	TX40
1pc.	1pc.	1pc.	1pc.	1pc.	1pc.

INCLUSO / INCLUDED  
INCLUDE / INCLUIDO

COD. 62013005



COD. 64221030



**66010**

## ASSORTIMENTI TORSION+

ASSORTIMENTO 31 PCS. - INSERTI + PORTAINSERI  
31 PCS. SET - BITS + BIT-HOLDER  
JEU 31 PCS. - EMBOUTS + PORTE-EMBOUTS  
JUEGO DE 31 PCS. - PUNTAS + PORTA PUNTAS

31  
pcs.



80 X 115 X 30 mm

COD. **66010035**

€ 43,700

61250			61260		
PH1	PH2	PH3	PZ1	PZ2	PZ3
2pcs.	4pcs.	3pcs.	2pcs.	4pcs.	3pcs.

61270			
TX20	TX25	TX30	TX40
3pcs.	3pcs.	3pcs.	3pcs.

INCLUSO / INCLUDED  
INCLUDE / INCLUIDO  
COD. 62013005





**66001**

# STORE 9 ASSORTIMENTI TORSION+

CASSETTIERA CON 9 SCOMPARTI PER ESPOSITORE MULTISTORE  
DRAWERS WITH 9 COMPARTMENTS FOR MULTISTORE DISPLAY  
TIROIRS AVEC 9 COMPARTIMENTS POUR PRESENTOIR MULTISTORE  
9 CAJONES PARA MOSTRADOR DE EXPOSICIÓN TIPO MULTISTORE

165  
pcs.



600 X 90 X 65 mm



## MULTI STORE

COD. 66001005VC

PER DETAGLI E COMPOSIZIONE VEDERE P. 184  
FOR DETAILS AND COMPOSITION SEE P. 184  
POUR LES DÉTAILS ET LA COMPOSITION VOIR P. 184  
PARA MÁS DETALLES Y COMPOSICIÓN VÉASE P. 184

COD. **66001065**

€ 175,000

61250			61260			61270		
PH1	PH2	PH3	PZ1	PZ2	PZ3	TX20	TX25	TX30
10pcs.	30pcs.	20pcs.	10pcs.	30pcs.	20pcs.	15pcs.	15pcs.	15pcs.

COD. **66001066**

€ 201,000

61250		61260		61270		
PH1	PH2	PZ1	PZ2	TX25	TX30	TX40
20pcs.	30pcs.	20pcs.	30pcs.	15pcs.	15pcs.	15pcs.

61251	61261
PH2	PZ2
10pcs.	10pcs.



# 1.1 LINEE PREMIUM

PREMIUM LINES  
LIGNES PREMIUM  
LÍNEAS PREMIUM

66001

**MULTI BIT**

ESPOSITORE INSERTI TORSION+

ESPOSITORE DA BANCO CON 25 SCOMPARTI  
COUNTER DISPLAY WITH 25 COMPARTMENTS  
PRÉSENTOIR DE COMPTOIR À 25 LOGEMENTS  
MOSTRADOR DE EXPOSICIÓN DE 25 ALOJAMIENTOS

310  
pcs.



COD. **66001315**

€ 578,000

61250			61260		
PH1 10pcs.	PH2 30pcs.	PH3 10pcs.	PZ1 10pcs.	PZ2 20pcs.	PZ3 10pcs.
61270					
TX10 10pcs.	TX15 10pcs.	TX20 20pcs.	TX25 20pcs.	TX30 20pcs.	TX40 10pcs.
61251			61261		
PH1 10pcs.	PH2 10pcs.	PH3 10pcs.	PZ1 10pcs.	PZ2 10pcs.	PZ3 10pcs.
61271					62015010
TX10 10pcs.	TX15 10pcs.	TX20 10pcs.	TX25 10pcs.	TX30 10pcs.	TX40 10pcs.
					 10pcs.

445 X 465 X 210 mm

STRUTTURA IN POLIPROPILENE ALVEOLARE AUTOPORTANTE, 25 SCOMPARTI.  
SELF-SUPPORTING POLYPROPYLENE HONEYCOMB STRUCTURE, 25 COMPARTMENTS.  
STRUCTURE EN POLYPROPYLÈNE ALVÉOLAIRE AUTOPORTANTE, 25 LOGEMENTS.  
ESTRUCTURA DE POLIPROPILENO ALVEOLAR AUTOSUSTENTADA, 25 ALOJAMIENTOS.

**66001****MULTI BOX****ESPOSITORE MINIBOX TORSION+**

ESPOSITORE DA BANCO IN FILO METALLICO PER MINIBOX  
 METAL WIRE COUNTER DISPLAY FOR MINIBOX  
 PRÉSENTOIR DE COMPTOIR EN FIL MÉTALLIQUE POUR MINIBOX  
 MOSTRADOR DE EXPOSICIÓN DE ALAMBRE PARA MINIBOX

**560 pcs.**COD. **66001515****€ 885,000**

			L mm	COD.	box	
10 pcs.		<b>PH1</b>	25	61250005010	4	
10 pcs.		<b>PH2</b>	25	61250010010	5	
10 pcs.		<b>PH3</b>	25	61250015010	4	
10 pcs.		<b>PZ1</b>	25	61260005010	4	
10 pcs.		<b>PZ2</b>	25	61260010010	5	
10 pcs.		<b>PZ3</b>	25	61260015010	4	
10 pcs.		<b>TX10</b>	25	61270005010	3	
10 pcs.		<b>TX15</b>	25	61270010010	3	
10 pcs.		<b>TX20</b>	25	61270015010	3	
10 pcs.		<b>TX25</b>	25	61270020010	4	
10 pcs.		<b>TX30</b>	25	61270030010	4	
5 pcs.		<b>PH1</b>	50	61251005005	3	
5 pcs.		<b>PH2</b>	50	61251010005	3	
5 pcs.		<b>PH3</b>	50	61251015005	3	
5 pcs.		<b>PZ1</b>	50	61261005005	3	
5 pcs.		<b>PZ2</b>	50	61261010005	3	
5 pcs.		<b>PZ3</b>	50	61261015005	3	
5 pcs.		<b>TX20</b>	50	61271015005	2	
5 pcs.		<b>TX25</b>	50	61271020005	2	
5 pcs.		<b>TX30</b>	50	61271030005	2	
1 pc.					62012010001	5
1 pc.					62016015001	5

**370 X 545 X 220 mm**

STRUTTURA IN FILO METALLICO DA BANCO ED APPENDIBILE ADATTA AD ACCOGLIERE 20 MISURE DIVERSE DI INSERTI CONFEZIONATI IN MINIBOX E DUE ARTICOLI ACCESSORI.

COUNTERTOP OR WALL-MOUNTED METAL WIRE STRUCTURE, SUITABLE FOR HOLDING BITS IN 20 DIFFERENT SIZES, MINIBOX PACKED AND TWO ACCESSORIES.

STRUCTURE EN FIL MÉTALLIQUE DE COMPTOIR ET À SUSPENDRE, ADAPTÉE POUR 20 TAILLES DIFFÉRENTES D'EMBOÛTS EMBALLÉS DANS UNE MINI-BOÎTE ET DEUX ARTICLES ACCESSOIRES.

ESTRUCTURA DE HILO METÁLICO PARA MOSTRADOR QUE SE PUEDE COLGAR APTA PARA ALOJAR 20 DIFERENTES MEDIDAS DE PUNTAS PUESTOS EN MINICAJAS MÁS DOS ARTÍCULOS DE ACCESORIOS.

## INSERTI 1/4" CON RIVESTIMENTO AL DIAMANTE

1/4" bits with diamond coating

Embouts 1/4" avec revêtement diamant

Puntas de 1/4" con recubrimiento de diamante

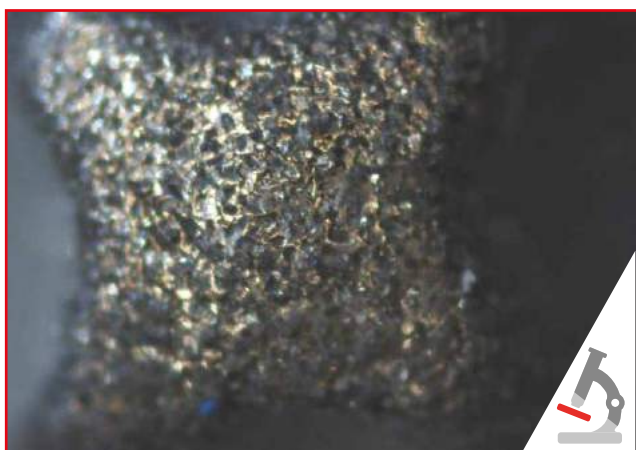

Rivestimento diamante elettrodepositato  
 Electro-deposited diamond coating  
 Revêtement diamant électrodéposé  
 Recubrimiento de diamante electrodepositado

### RIDUZIONE DELL'EFFETTO COME-OUT

Reduced come-out effect / réduction de l'effet come-out / reducción del efecto de salida (come out)

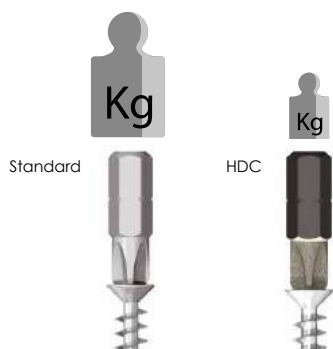

Applicazioni  
 applications  
 aplicaciones

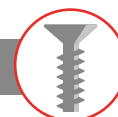

Le minuscole particelle di diamante fanno presa nella cava della vite, si riduce l'effetto come-out, l'operatore può avvitare con meno forza e più sicurezza.

The tiny diamond particles become entrapped in the slot of the screws, reducing the come-out effect, so that the operator can screw with less force and greater safety.

Les minuscules particules de diamant font prises dans la rainure de la vis, l'effet de sortie se réduit, l'utilisateur peut visser avec moins de force et plus de sécurité.

Las minúsculas partículas de diamante se agarran dentro de la ranura del tornillo, se reduce el efecto come-out y el operador puede atornillar con menor fuerza y más seguridad.



L'inserto non scivola dalla vite, diminuisce il rischio di rovinare sia la punta dell'utensile che la testa della vite.

The bit does not slip from the screw, which reduces the risk of damaging the tool tip and screw head.

L'embout ne glisse pas de la vis, il diminue le risque d'abimer la pointe de l'outil ainsi que la tête de la vis.

La punta no resbala del tornillo, disminuye el riesgo de estropear ya sea la punta del utensilio que la cabeza del tornillo.



L'ottimo grip che esercita questo rivestimento permette di utilizzare gli inserti HDC anche per svitare viti danneggiate o arrugginite.

The excellent grip exerted by this coating allows using HDC bits also to unscrew damaged or rusty screws.

La bonne adhérence qu'exerce ce revêtement permet d'utiliser les embouts HDC même pour dévisser des vis rouillées ou abîmées.

El óptimo agarre que proporciona este recubrimiento permite utilizar los PUNTAS HDC también para destornillar tornillos dañados u oxidados.



**61310****PH HDC**

INSERTI 1/4" C PHILLIPS® - CON RIVESTIMENTO AL DIAMANTE  
 1/4" C PHILLIPS® BITS - WITH DIAMOND COATING  
 EMBOUTS 1/4" C PHILLIPS® - AVEC REVÊTEMENT DIAMANT  
 PUNTAS DE 1/4" C PHILLIPS® - CON RECUBRIMIENTO DE DIAMANTE

58/60 HRC

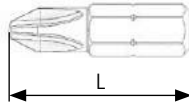
**EASYPACK** | sacchetto PVC con Euro-hole • PVC bags with Euro-hole

	L mm	PCS.	COD.	€ cad./each
<b>PH1</b>	25	10	61310005	2,950
<b>PH2</b>	25	10	61310010	2,950
<b>PH3</b>	25	10	61310015	2,950

**SELPACK**  
2 pcs.

	L mm	COD.	€ box
<b>PH1</b>	25	61310005002	7,230
<b>PH2</b>	25	61310010002	7,230
<b>PH3</b>	25	61310015002	7,230

**MINIBOX**  
10 pcs.

	L mm	COD.	€ box
<b>PH1</b>	25	61310005010	31,000
<b>PH2</b>	25	61310010010	31,000
<b>PH3</b>	25	61310015010	31,000

**61311****PH HDC**

LAME 1/4" E PHILLIPS® - CON RIVESTIMENTO AL DIAMANTE  
 1/4" E PHILLIPS® POWER BITS - WITH DIAMOND COATING  
 EMBOUTS 1/4" E PHILLIPS® - AVEC REVÊTEMENT DIAMANT  
 PUNTAS DE 1/4" E PHILLIPS® - CON RECUBRIMIENTO DE DIAMANTE

58/60 HRC

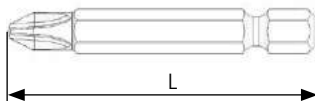
**EASYPACK** | sacchetto PVC con Euro-hole • PVC bags with Euro-hole

	L mm	PCS.	COD.	€ cad./each
<b>PH1</b>	50	5	61311005	4,160
<b>PH2</b>	50	5	61311010	4,160
<b>PH3</b>	50	5	61311015	4,160

**SELPACK**  
2 pcs.

	L mm	COD.	€ box
<b>PH1</b>	50	61311005002	9,650
<b>PH2</b>	50	61311010002	9,650
<b>PH3</b>	50	61311015002	9,650

**MINIBOX**  
5 pcs.

	L mm	COD.	€ box
<b>PH1</b>	50	61311005005	21,800
<b>PH2</b>	50	61311010005	21,800
<b>PH3</b>	50	61311015005	21,800



# 1.1 LINEE PREMIUM

PREMIUM LINES  
LIGNES PREMIUM  
LÍNEAS PREMIUM

61320

PZ HDC



INSERTI 1/4"C POZIDRIV® - CON RIVESTIMENTO AL DIAMANTE  
1/4"C POZIDRIV® BITS - WITH DIAMOND COATING  
EMBOUS 1/4"C POZIDRIV® - AVEC REVÊTEMENT DIAMANT  
PUNTAS DE 1/4"C POZIDRIV® - CON RECUBRIMIENTO DE DIAMANTE

58/60 HRC

EASYPACK | sacchetto PVC con Euro-hole • PVC bags with Euro-hole

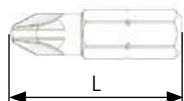

	L mm	PCS.	COD.	€ cad./each
<b>PZ1</b>	25	10	61320005	2,950
<b>PZ2</b>	25	10	61320010	2,950
<b>PZ3</b>	25	10	61320015	2,950



	L mm	COD.	€ box
<b>PZ1</b>	25	61320005002	7,230
<b>PZ2</b>	25	61320010002	7,230
<b>PZ3</b>	25	61320015002	7,230

SELPACK  
2 pcs.



	L mm	COD.	€ box
<b>PZ1</b>	25	61320005010	31,000
<b>PZ2</b>	25	61320010010	31,000
<b>PZ3</b>	25	61320015010	31,000

MINIBOX  
10 pcs.

61321

PZ HDC



LAME 1/4"E POZIDRIV® - CON RIVESTIMENTO AL DIAMANTE  
1/4"E POZIDRIV® POWER BITS - WITH DIAMOND COATING  
EMBOUS 1/4"E POZIDRIV® - AVEC REVÊTEMENT DIAMANT  
PUNTAS DE 1/4"E POZIDRIV® - CON RECUBRIMIENTO DE DIAMANTE

58/60 HRC

EASYPACK | sacchetto PVC con Euro-hole • PVC bags with Euro-hole

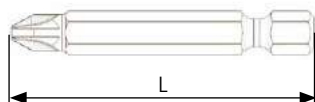

	L mm	PCS.	COD.	€ cad./each
<b>PZ1</b>	50	5	61321005	4,160
<b>PZ2</b>	50	5	61321010	4,160
<b>PZ3</b>	50	5	61321015	4,160



	L mm	COD.	€ box
<b>PZ1</b>	50	61321005002	9,650
<b>PZ2</b>	50	61321010002	9,650
<b>PZ3</b>	50	61321015002	9,650

SELPACK  
2 pcs.



	L mm	COD.	€ box
<b>PZ1</b>	50	61321005005	21,800
<b>PZ2</b>	50	61321010005	21,800
<b>PZ3</b>	50	61321015005	21,800

MINIBOX  
5 pcs.

**61330****TX HDC**

INSERTI 1/4"C PER VITI TORX® - CON RIVESTIMENTO AL DIAMANTE  
 1/4"C BITS FOR TORX® SCREWS - WITH DIAMOND COATING  
 EMBOUTS 1/4"C POUR VIS TORX® - AVEC REVÊTEMENT DIAMANT  
 PUNTAS DE 1/4"C PARA TORNILLOS TORX® - CON RECUBRIMIENTO DE DIAMANTE

58/60 HRC

EASYPACK | sacchetto PVC con Euro-hole • PVC bags with Euro-hole

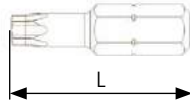

	L mm	PCS.	COD.	€ cad./each
<b>TX10</b>	25	10	61330005	3,220
<b>TX15</b>	25	10	61330010	3,220
<b>TX20</b>	25	10	61330015	3,220
<b>TX25</b>	25	10	61330020	3,220
<b>TX30</b>	25	10	61330030	3,220
<b>TX40</b>	25	10	61330035	3,220

	L mm	COD.	€ box
<b>TX10</b>	25	61330005002	7,770
<b>TX15</b>	25	61330010002	7,770
<b>TX20</b>	25	61330015002	7,770
<b>TX25</b>	25	61330020002	7,770
<b>TX30</b>	25	61330030002	7,770
<b>TX40</b>	25	61330035002	7,770

SELPACK  
2 pcs.MINIBOX  
10 pcs.

	L mm	COD.	€ box
<b>TX10</b>	25	61330005010	33,800
<b>TX15</b>	25	61330010010	33,800
<b>TX20</b>	25	61330015010	33,800
<b>TX25</b>	25	61330020010	33,800
<b>TX30</b>	25	61330030010	33,800
<b>TX40</b>	25	61330035010	33,800

**61305****TAGLIO HDC**

INSERTI 1/4"C A TAGLIO - CON RIVESTIMENTO AL DIAMANTE  
 1/4"C SLOTTED BITS - WITH DIAMOND COATING  
 EMBOUTS 1/4"C À FENTE - AVEC REVÊTEMENT DIAMANT  
 PUNTAS DE 1/4"C DE CORTE - CON RECUBRIMIENTO DE DIAMANTE

58/60 HRC

EASYPACK | sacchetto PVC con Euro-hole • PVC bags with Euro-hole

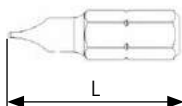

	Ø mm	L mm	PCS.	COD.	€ cad./each
<b>0,5</b>	3	25	10	61305005	3,350
<b>0,6</b>	4	25	10	61305010	3,350
<b>0,6</b>	4,5	25	10	61305015	3,350
<b>0,8</b>	5,5	25	10	61305020	3,350
<b>1,2</b>	6,5	25	10	61305025	3,350

	Ø mm	L mm	COD.	€ box
<b>0,5</b>	3	25	61305005002	8,040
<b>0,6</b>	4	25	61305010002	8,040
<b>0,6</b>	4,5	25	61305015002	8,040
<b>0,8</b>	5,5	25	61305020002	8,040
<b>1,2</b>	6,5	25	61305025002	8,040

SELPACK  
2 pcs.MINIBOX  
10 pcs.

	Ø mm	L mm	COD.	€ box
<b>0,5</b>	3	25	61305005010	35,100
<b>0,6</b>	4	25	61305010010	35,100
<b>0,6</b>	4,5	25	61305015010	35,100
<b>0,8</b>	5,5	25	61305020010	35,100
<b>1,2</b>	6,5	25	61305025010	35,100



# 1.1 LINEE PREMIUM

PREMIUM LINES  
LIGNES PREMIUM  
LÍNEAS PREMIUM

66002

## MYBIT 7 ASSORTIMENTI HDC

ASSORTIMENTO 7 PCS. - INSERTI + PORTAINSERTI  
7 PCS. SET - BITS + BIT-HOLDER  
JEU 7 PCS. - EMBOUTS + PORTE-EMBOUTS  
JUEGO DE 7 PCS. - PUNTAS + PORTA PUNTAS



7  
pcs.

COD. **66002380**

€ 23,900

61310



PH1  
1pc.

PH2  
1pc.

61320



PZ1  
1pc.

PZ2  
1pc.

61305



0,6x4,5  
1pc.

1,2x6,5  
1pc.

COD. **66002385**

€ 23,800

61330



TX10  
1pc.

TX15  
1pc.

TX20  
1pc.

TX25  
1pc.

TX30  
1pc.

TX40  
1pc.

COD. **66002390**

€ 22,800

61310



PH1  
1pc.

PH2  
1pc.

61320



PZ1  
1pc.

PZ2  
1pc.

61330



TX25  
1pc.

TX30  
1pc.

INCLUSO / INCLUDED  
INCLUSE / INCLUIDO

COD. 62015010



100 X 120 mm

66002

## DISPLAY MYBIT 7 HDC

ESPOSITORE DA BANCO IN PLEXIGLASS PER 12 BIT-SETS  
12 PCS. BIT-SETS PLEXIGLASS COUNTER DISPLAY  
PRÉSENTOIR EN PLEXIGLASS POUR 12 JEUX D'EMBOUTS  
MOSTRADOR DE EXPOSICIÓN IN PLEXIGLASS PARA 12 BIT-SET



12  
pcs.

COD. **66002384**

€ 286,800



12 pcs.  
COD. 66002380

COD. **66002389**

€ 285,600



12 pcs.  
COD. 66002385

COD. **66002394**

€ 273,600



12 pcs.  
COD. 66002390

150 X 40 X 195 mm



**66007**

**MYBIT 7 POWER**  
ASSORTIMENTI HDC

ASSORTIMENTO 7 PCS. - INSERTI  
7 PCS. SET - BITS  
JEU 7 PCS. - EMBOUTS  
JUEGO 7 PCS. - PUNTAS

**NEW!**



7  
pcs.

COD. **66007385**

€ 23,300

61311 L=50mm



PH1 | PH2 | PH3  
1pc. | 2pcs. | 1pc.

61321 L=50mm



PZ1 | PZ2 | PZ3  
1pc. | 1pc. | 1pc.



100 X 120 mm





# 1.1 LINEE PREMIUM

PREMIUM LINES  
LIGNES PREMIUM  
LÍNEAS PREMIUM

**66005**

**MYBIT 10**

ASSORTIMENTI HDC

ASSORTIMENTO 10 PCS. - INSERTI + PORTAINSERI  
10 PCS. SET - BITS + BIT-HOLDER  
JEU 10 PCS. - EMBOUTS + PORTE-EMBOUTS  
JUEGO DE 10 PCS. - PUNTAS + PORTA PUNTAS

COD. **66005380**

€ 31,500



10  
pcs.

61310			61320			61305		
PH1	PH2	PH3	PZ1	PZ2	PZ3	0,6x4,5	0,8x5,5	1,2x6,5
1pc.	1pc.	1pc.	1pc.	1pc.	1pc.	1pc.	1pc.	1pc.

COD. **66005385**

€ 31,100

61310			61320			61330		
PH1	PH2	PH3	PZ1	PZ2	PZ3	TX25	TX30	TX40
1pc.	1pc.	1pc.	1pc.	1pc.	1pc.	1pc.	1pc.	1pc.

COD. **66005390**

€ 34,500

61310		61320		61330		61305		
PH2	PH3	PZ2	PZ3	TX25	TX30	0,6x4,5	0,8x5,5	1,2x6,5
1pc.	1pc.	1pc.	1pc.	1pc.	1pc.	1pc.	1pc.	1pc.



100 X 120 mm



INCLUSO / INCLUDED  
INCLUDE / INCLUIDO

COD. 62015010



**66005**

**DISPLAY MYBIT 10**  
HDC

ESPOSITORE DA BANCO IN PLEXIGLASS PER 12 BIT-SETS  
12 PCS. BIT-SETS PLEXIGLASS COUNTER DISPLAY  
PRÉSENTOIR EN PLEXIGLASS POUR 12 JEUX D'EMBOUTS  
MOSTRADOR DE EXPOSICIÓN IN PLEXIGLASS PARA 12 BIT-SET

COD. **66005384**

€ 378,000

12  
pcs.



12 pcs.  
COD. 66005380

COD. **66005389**

€ 373,200



12 pcs.  
COD. 66005385

COD. **66005394**

€ 414,000



12 pcs.  
COD. 66005390



150 X 40 X 195 mm



**66006** **MYBIT 15**  
ASSORTIMENTI HDC

ASSORTIMENTO 15 PCS. - INSERTI + PORTAINSERI  
15 PCS. SET - BITS + BIT-HOLDER  
JEU 15 PCS. - EMBOUTS + PORTE-EMBOUTS  
JUEGO DE 15 PCS. - PUNTAS + PORTA PUNTAS



15 pcs.

COD. **66006320**  
€ 45,000

61310			61320		
PH1 1pc.	PH2 1pc.	PH3 1pc.	PZ1 1pc.	PZ2 1pc.	PZ3 1pc.
61330			61305		
TX20 1pc.	TX25 1pc.	TX30 1pc.	0,6x4,0 1pc.	0,8x5,5 1pc.	1,2x6,5 1pc.
61311			61321		
PH2 1pc.			PZ2 1pc.		



100 X 167 mm



INCLUSO / INCLUDED  
INCLUDE / INCLUIDO  
COD. 62015010



**66006** **DISPLAY MYBIT 15**  
HDC

ESPOSITORE DA BANCO IN PLEXIGLASS PER 12 BIT-SETS  
12 PCS. BIT-SETS PLEXIGLASS COUNTER DISPLAY  
PRÉSENTOIR EN PLEXIGLAS POUR 12 JEUX D'EMBOUTS  
MOSTRADOR DE EXPOSICIÓN IN PLEXIGLASS PARA 12 BIT-SET



12 pcs.

COD. **66006324**  
€ 540,000



12 pcs.  
COD. 66006320

185 X 40 X 195 mm



# 1.1 LINEE PREMIUM

PREMIUM LINES  
LIGNES PREMIUM  
LÍNEAS PREMIUM

## 66006 MYBIT 14 HDC CON CRICCHETTO

ASSORTIMENTO 14 PCS. HDC / CRICCHETTO  
14 PCS. SET - BITS + BIT HOLDER AND RATCHET  
JEU 14 PCS. - EMBOUTS + PORTE-EMBOUTS  
JUEGO DE 14 PCS. - PUNTAS + PORTA PUNTAS

**NEW!**

14 pcs.

COD. **66006515**

€ 48,600



100 X 170 mm



61310			61320		
PH1 1pc.	PH2 1pc.	PH3 1pc.	PZ1 1pc.	PZ2 1pc.	PZ3 1pc.
61330			61305		
TX20 1pc.	TX25 1pc.	TX30 1pc.	4x0,6 1pc.	5,5x0,8 1pc.	6,5x1,2 1pc.

INCLUSO / INCLUDED  
INCLUSE / INCLUIDO

COD. 62015010

COD. 64221030



## 66010 ASSORTIMENTI HDC

ASSORTIMENTO 31 PCS. - INSERTI + PORTAINSERI  
31 PCS. SET - BITS + BIT-HOLDER  
JEU 31 PCS. - EMBOUTS + PORTE-EMBOUTS  
JUEGO DE 31 PCS. - PUNTAS + PORTA PUNTAS

31 pcs.

COD. **66010040**

€ 90,900



80 X 115 X 30 mm

61310			61320		
PH1 2pcs.	PH2 2pcs.	PH3 2pcs.	PZ1 2pcs.	PZ2 2pcs.	PZ3 2pcs.
61330					
TX10 1pc.	TX15 1pc.	TX20 1pc.	TX25 2pcs.	TX30 2pcs.	TX40 2pcs.
61305					
0,5x3,0 1pc.	0,6x4,0 2pcs.	0,6x4,5 2pcs.	0,8x5,5 2pcs.	1,2x6,5 2pcs.	

INCLUSO / INCLUDED  
INCLUSE / INCLUIDO

COD. 62015010







**66001**

# STORE 9 ASSORTIMENTI HDC

CASSETTIERA CON 9 SCOMPARTI PER ESPOSITORE MULTISTORE  
DRAWERS WITH 9 COMPARTMENTS FOR MULTISTORE DISPLAY  
TIROIRS AVEC 9 COMPARTIMENTS POUR PRESENTOIR MULTISTORE  
9 CAJONES PARA MOSTRADOR DE EXPOSICIÓN TIPO MULTISTORE

110  
pcs.



600 X 90 X 65 mm



## MULTI STORE

COD. 66001005VC

PER DETAGLI E COMPOSIZIONE VEDERE P. 184  
FOR DETAILS AND COMPOSITION SEE P. 184  
POUR LES DÉTAILS ET LA COMPOSITION VOIR P. 184  
PARA MÁS DETALLES Y COMPOSICIÓN VÉASE P. 184

COD. **66001070**

€ 259,000

61310		61320		61330			61305	
PH2	PH3	PZ2	PZ3	TX25	TX30	TX40	0,6x4,5	1,2x6,5
20pcs.	10pcs.	20pcs.	10pcs.	10pcs.	10pcs.	10pcs.	10pcs.	10pcs.

COD. **66001071**

€ 271,000

61310		61320		61330		
PH1	PH2	PZ1	PZ2	TX25	TX30	TX40
10pcs.	20pcs.	10pcs.	20pcs.	10pcs.	10pcs.	10pcs.

61311	61321
PH2	PZ2
10pcs.	10pcs.



# 1.1 LINEE PREMIUM

PREMIUM LINES  
LIGNES PREMIUM  
LÍNEAS PREMIUM

66001

**MULTI BIT**

ESPOSITORE INSERTI HDC

265  
pcs.



445 X 465 X 210 mm

STRUTTURA IN POLIPROPILENE ALVEOLARE AUTOPORTANTE, 25 SCOMPARTI.  
SELF-SUPPORTING POLYPROPYLENE HONEYCOMB STRUCTURE, 25 COMPARTMENTS.  
STRUCTURE EN POLYPROPYLÈNE ALVÉOLAIRE AUTOPORTANTE, 25 LOGEMENTS.  
ESTRUCTURA DE POLIPROPILENO ALVEOLAR AUTOSUSTENTADA, 25 ALOJAMIENTOS.

ESPOSITORE DA BANCO CON 25 SCOMPARTI  
COUNTER DISPLAY WITH 25 COMPARTMENTS  
PRÉSENTOIR DE COMPTOIR À 25 LOGEMENTS  
MOSTRADOR DE EXPOSICIÓN DE 25 ALOJAMIENTOS

COD. **66001320**

€ 714,000

<p>61310 </p>			<p>61320 </p>		
PH1 10pcs.	PH2 20pcs.	PH3 10pcs.	PZ1 10pcs.	PZ2 20pcs.	PZ3 10pcs.
<p>61330 </p>					
TX10 10pcs.	TX15 10pcs.	TX20 10pcs.	TX25 10pcs.	TX30 10pcs.	TX40 10pcs.
<p>61311 </p>			<p>61321 </p>		
PH1 10pcs.	PH2 10pcs.	PH3 10pcs.	PZ1 10pcs.	PZ2 10pcs.	PZ3 10pcs.
<p>61305 </p>					
0,5x3,0 10pcs.	0,6x4,0 10pcs.	0,6x4,5 10pcs.	0,8x5,5 10pcs.	1,2x6,5 10pcs.	
<p>62015010 </p>			<p>62022005 </p>		
<p> </p> <p>10pcs.</p>			<p> </p> <p>5pcs</p>		

**66001****MULTIBOX****ESPOSITORE MINIBOX HDC**

ESPOSITORE DA BANCO IN FILO METALLICO PER MINIBOX  
 METAL WIRE COUNTER DISPLAY FOR MINIBOX  
 PRÉSENTOIR DE COMPTOIR EN FIL MÉTALLIQUE POUR MINIBOX  
 MOSTRADOR DE EXPOSICIÓN DE ALAMBRE PARA MINIBOX

**548  
pcs.**COD. **66001525****€ 1'457,000**

			L mm	COD.	box
10 pcs.		<b>PH1</b>	25	61310005010	4
10 pcs.		<b>PH2</b>	25	61310010010	5
10 pcs.		<b>PH3</b>	25	61310015010	4
10 pcs.		<b>PZ1</b>	25	61320005010	4
10 pcs.		<b>PZ2</b>	25	61320010010	5
10 pcs.		<b>PZ3</b>	25	61320015010	4
10 pcs.		<b>0,5x3,0</b>	25	61305005010	2
10 pcs.		<b>0,6x4,0</b>	25	61305010010	2
10 pcs.		<b>0,6x4,5</b>	25	61305015010	2
10 pcs.		<b>0,8x5,5</b>	25	61305020010	2
10 pcs.		<b>1,2x6,5</b>	25	61305025010	2
10 pcs.		<b>TX25</b>	25	61330020010	3
10 pcs.		<b>TX30</b>	25	61330030010	3
10 pcs.		<b>TX40</b>	25	61330035010	3
5 pcs.		<b>PH1</b>	50	61311005005	3
5 pcs.		<b>PH2</b>	50	61311010005	3
5 pcs.		<b>PH3</b>	50	61311015005	3
5 pcs.		<b>PZ1</b>	50	61321005005	3
5 pcs.		<b>PZ2</b>	50	61321010005	3
5 pcs.		<b>PZ3</b>	50	61321015005	3
1 pc.				62029005	3
1 pc.				62015010001	5

**370 X 545 X 220 mm**

STRUTTURA IN FILO METALLICO DA BANCO ED APPENDIBILE ADATTA AD ACCOGLIERE 20 MISURE DIVERSE DI INSERTI CONFEZIONATI IN MINIBOX E DUE ARTICOLI ACCESSORI.

COUNTERTOP OR WALL-MOUNTED METAL WIRE STRUCTURE, SUITABLE FOR HOLDING BITS IN 20 DIFFERENT SIZES, MINIBOX PACKED AND TWO ACCESSORIES.

STRUCTURE EN FIL MÉTALLIQUE DE COMPTOIR ET À SUSPENDRE, ADAPTÉE POUR 20 TAILLES DIFFÉRENTES D'EMBOUS EMBALLÉS DANS UNE MINI-BOÎTE ET DEUX ARTICLES ACCESSOIRES.

ESTRUCTURA DE HILO METÁLICO PARA MOSTRADOR QUE SE PUEDE COLGAR APTA PARA ALOJAR 20 DIFERENTES MEDIDAS DE PUNTAS PUESTOS EN MINICAJAS MÁS DOS ARTÍCULOS DE ACCESORIOS.

# TITANIUM



## INSERTI 1/4" CON RIVESTIMENTO AL NITRURO DI TITANIO

1/4" bits with titanium nitride coating

Embouts 1/4" avec revêtement nitrure de titane

Puntas de 1/4" con recubrimiento de nitruro de titanio

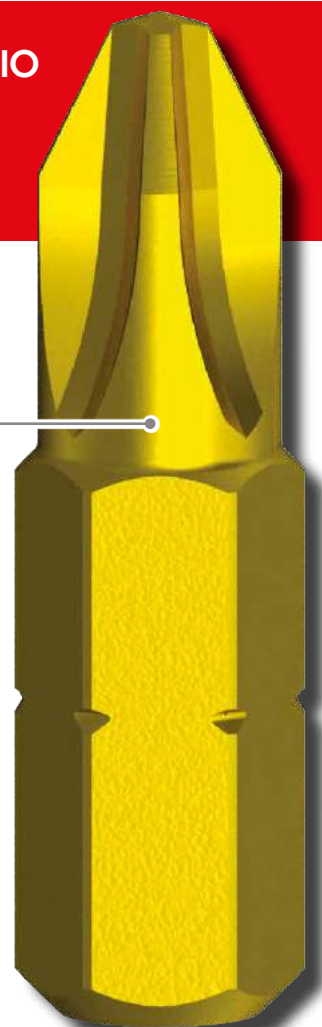

Rivestimento nitruro di titanio PVD - TiN  
 PVD titanium-nitride coating - TiN  
 Revêtement nitrure de titane PVD - TiN  
 Recubrimiento de nitruro de titanio PVD - TiN

### DUREZZA SUPERFICIALE

Surface hardness / dureté de la surface / dureza superficial

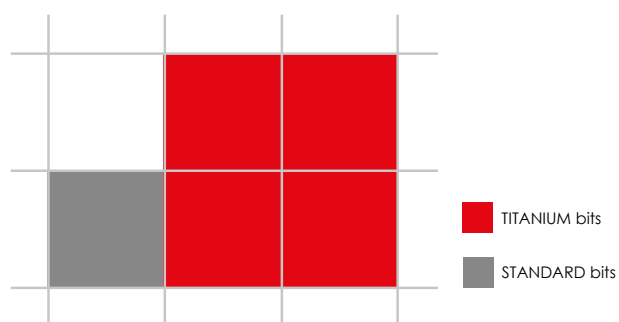

Applicazioni  
 applications  
 applications  
 aplicaciones

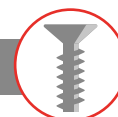

Rivestimento al nitruro di titanio estremamente duro (2500 HV), ottima resistenza all'usura e all'ossidazione.

Extremely hard titanium-nitride coating (2500 HV), excellent resistance to wear and oxidation.

Revêtement au nitrure de titane extrêmement dur (2500 HV), excellente résistance à l'usure et à l'oxydation.

Recubrimiento al nitruro de titanio extremadamente duro (2500 HV), óptima resistencia al desgaste y a la oxidación.



Per avvitamenti multipli a bassi valori di coppia.

For low torque screwing jobs.

Pour des vissages multiples à petites valeurs de couple.

Para atornillados múltiples con bajos valores de par de torsión.



Il rivestimento permette all'utensile di sopportare al meglio elevate e ripetute sollecitazioni aumentandone la vita.

The coating allows the tool to better withstand high and repeated stress, thus increasing its life.

Le revêtement permet à l'outil de supporter au mieux les sollicitations répétées et élevées en augmentant sa durée de vie.

El recubrimiento permite que el utensilio pueda soportar muy bien elevados y repetidos esfuerzos alargando su duración.

**61045****PH TITANIUM**

INSERTI 1/4" C PHILLIPS® - RIVESTIMENTO NITRURO DI TITANIO  
 1/4" C PHILLIPS® BITS - TITANIUM NITRIDE COATING  
 EMBOUTS 1/4" C PHILLIPS® - REVÊTEMENT NITRURE DE TITANE  
 PUNTAS DE 1/4" C PHILLIPS® - RECUBRIMIENTO DE NITRURO DE TITANIO

59/60 HRC

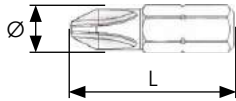
**EASYPACK** | sacchetto PVC con Euro-hole • PVC bags with Euro-hole

+	L mm	Ø mm	PCS.	COD.	€ cad./each
PH1	25	4,5	10	61045005	1,610
PH2	25	4,5	10	61045010	1,610
	25	6	10	61045015	1,610
PH3	25	6	10	61045020	1,610



+	L mm	COD.	€ box
PH1	25	61045005002	4,560
PH2	25	61045015002	4,560
PH3	25	61045020002	4,560

SELFPACK  
2 pcs.

+	L mm	COD.	€ box
PH1	25	61045005010	18,100
PH2	25	61045015010	18,100
PH3	25	61045020010	18,100

MINIBOX  
10 pcs.**61052****PH TITANIUM**

LAME 1/4" E PHILLIPS® - RIVESTIMENTO NITRURO DI TITANIO  
 1/4" E PHILLIPS® POWER BITS - TITANIUM NITRIDE COATING  
 EMBOUTS 1/4" E PHILLIPS® - REVÊTEMENT NITRURE DE TITANE  
 PUNTAS DE 1/4" E PHILLIPS® - RECUBRIMIENTO DE NITRURO DE TITANIO

59/60 HRC

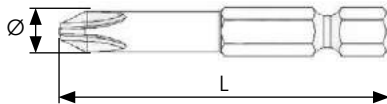
**EASYPACK** | sacchetto PVC con Euro-hole • PVC bags with Euro-hole

+	L mm	Ø mm	PCS.	COD.	€ cad./each
PH1	50	4,5	5	61052005	3,700
PH2	50	6	5	61052010	3,700
PH3	50	6	5	61052015	3,700



+	L mm	COD.	€ box
PH1	50	61052005002	8,730
PH2	50	61052010002	8,730
PH3	50	61052015002	8,730

SELFPACK  
2 pcs.

+	L mm	COD.	€ box
PH1	50	61052005005	19,500
PH2	50	61052010005	19,500
PH3	50	61052015005	19,500

MINIBOX  
5 pcs.



# 1.1 LINEE PREMIUM

PREMIUM LINES  
LIGNES PREMIUM  
LÍNEAS PREMIUM

**61071**

**PZ TITANIUM**



INSERTI 1/4" C POZIDRIV® - RIVESTIMENTO NITRURO DI TITANIO  
1/4" C POZIDRIV® BITS - TITANIUM NITRIDE COATING  
EMBOUTS 1/4 "C POZIDRIV® - REVÊTEMENT NITRURE DE TITANE  
PUNTAS DE 1/4" C POZIDRIV® - RECUBRIMIENTO DE NITRURO DE TITANIO

59/60 HRC

**EASYPACK** | sacchetto PVC con Euro-hole • PVC bags with Euro-hole

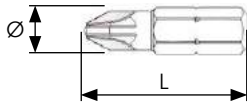

+	L mm	Ø mm	PCS.	COD.	€ cad./each
<b>PZ1</b>	25	4,5	10	61071005	1,610
<b>PZ2</b>	25	6	10	61071010	1,610
<b>PZ3</b>	25	6	10	61071015	1,610



**SELPACK**  
2 pcs.

+	L mm	COD.	€ box
<b>PZ1</b>	25	61071005002	4,560
<b>PZ2</b>	25	61071010002	4,560
<b>PZ3</b>	25	61071015002	4,560



**MINIBOX**  
10 pcs.

+	L mm	COD.	€ box
<b>PZ1</b>	25	61071005010	18,100
<b>PZ2</b>	25	61071010010	18,100
<b>PZ3</b>	25	61071015010	18,100

**61078**

**PZ TITANIUM**



LAME 1/4" E POZIDRIV® - RIVESTIMENTO NITRURO DI TITANIO  
1/4" E POZIDRIV® POWER BITS - TITANIUM NITRIDE COATING  
EMBOUTS 1/4 "E POZIDRIV® - REVÊTEMENT NITRURE DE TITANE  
PUNTAS DE 1/4" E POZIDRIV® - RECUBRIMIENTO DE NITRURO DE TITANIO

59/60 HRC

**EASYPACK** | sacchetto PVC con Euro-hole • PVC bags with Euro-hole



+	L mm	Ø mm	PCS.	COD.	€ cad./each
<b>PZ1</b>	50	4,5	5	61078005	3,700
<b>PZ2</b>	50	6	5	61078010	3,700
<b>PZ3</b>	50	6	5	61078015	3,700



**SELPACK**  
2 pcs.

+	L mm	COD.	€ box
<b>PZ1</b>	50	61078005002	8,730
<b>PZ2</b>	50	61078010002	8,730
<b>PZ3</b>	50	61078015002	8,730



**MINIBOX**  
5 pcs.

+	L mm	COD.	€ box
<b>PZ1</b>	50	61078005005	19,500
<b>PZ2</b>	50	61078010005	19,500
<b>PZ3</b>	50	61078015005	19,500

**61095 TX TITANIUM**

INSERTI 1/4" C PER VITI TORX® - RIVESTIMENTO NITRURO DI TITANIO  
 1/4" C BITS FOR TORX® SCREWS - TITANIUM NITRIDE COATING  
 EMBOUTS 1/4 "C POUR VIS TORX® - REVÊTEMENT NITRURE DE TITANE  
 PUNTAS DE 1/4" C PARA TORNILLOS TORX® - RECUBRIMIENTO DE NITRURO DE TITANIO

59/60 HRC

EASYPACK | sacchetto PVC con Euro-hole • PVC bags with Euro-hole

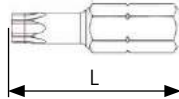

	L mm	PCS.	COD.	€ cad./each
<b>TX10</b>	25	10	61095005	2,190
<b>TX15</b>	25	10	61095010	2,190
<b>TX20</b>	25	10	61095015	2,190
<b>TX25</b>	25	10	61095020	2,190
<b>TX27</b>	25	10	61095025	2,190
<b>TX30</b>	25	10	61095030	2,190
<b>TX40</b>	25	10	61095035	2,190

	L mm	COD.	€ box
<b>TX10</b>	25	61095005002	5,710
<b>TX15</b>	25	61095010002	5,710
<b>TX20</b>	25	61095015002	5,710
<b>TX25</b>	25	61095020002	5,710
<b>TX27</b>	25	61095025002	5,710
<b>TX30</b>	25	61095030002	5,710
<b>TX40</b>	25	61095035002	5,710

	L mm	COD.	€ box
<b>TX10</b>	25	61095005010	23,300
<b>TX15</b>	25	61095010010	23,300
<b>TX20</b>	25	61095015010	23,300
<b>TX25</b>	25	61095020010	23,300
<b>TX27</b>	25	61095025010	23,300
<b>TX30</b>	25	61095030010	23,300
<b>TX40</b>	25	61095035010	23,300

SELPACK  
2 pcs.MINIBOX  
10 pcs.**61026 TAGLIO TITANIUM**

INSERTI 1/4" C A TAGLIO - RIVESTIMENTO NITRURO DI TITANIO  
 1/4" C SLOTTED BITS - TITANIUM NITRIDE COATING  
 EMBOUTS 1/4 "C À FENTE - REVÊTEMENT NITRURE DE TITANE  
 PUNTAS DE 1/4" C DE CORTE - RECUBRIMIENTO DE NITRURO DE TITANIO

59/60 HRC

EASYPACK | sacchetto PVC con Euro-hole • PVC bags with Euro-hole

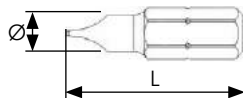

	Ø mm	L mm	PCS.	COD.	€ cad./each
<b>0,5</b>	3	25	10	61026001	2,280
<b>0,6</b>	4	25	10	61026005	2,280
<b>0,6</b>	4,5	25	10	61026008	2,280
<b>0,8</b>	5,5	25	10	61026010	2,280
<b>1,2</b>	6,5	25	10	61026015	2,280

	Ø mm	L mm	COD.	€ box
<b>0,5</b>	3	25	61026001002	5,900
<b>0,6</b>	4	25	61026005002	5,900
<b>0,6</b>	4,5	25	61026008002	5,900
<b>0,8</b>	5,5	25	61026010002	5,900
<b>1,2</b>	6,5	25	61026015002	5,900

	Ø mm	L mm	COD.	€ box
<b>0,5</b>	3	25	61026001010	24,200
<b>0,6</b>	4	25	61026005010	24,200
<b>0,6</b>	4,5	25	61026008010	24,200
<b>0,8</b>	5,5	25	61026010010	24,200
<b>1,2</b>	6,5	25	61026015010	24,200

SELPACK  
2 pcs.MINIBOX  
10 pcs.



# 1. LINEE PREMIUM

PREMIUM LINES  
LIGNES PREMIUM  
LÍNEAS PREMIUM

66002

MYBIT 7

ASSORTIMENTI TITANIUM

ASSORTIMENTO 7 PCS. - INSERTI + PORTAINSERI  
7 PCS. SET - BITS + BIT-HOLDER  
JEU 7 PCS. - EMBOUTS + PORTE-EMBOUTS  
JUEGO DE 7 PCS. - PUNTAS + PORTA PUNTAS



7  
pcs.



100 X 120 mm



INCLUSO / INCLUDED  
INCLUDE / INCLUIDO  
COD. 62013005



COD. **66002110**  
€ 15,700



PH1  
1pc.



PH2  
1pc.



PZ1  
1pc.

PZ2  
1pc.

0,6x4,5  
1pc.

1,2x6,5  
1pc.

COD. **66002120**  
€ 15,500



TX10  
1pc.

TX15  
1pc.

TX20  
1pc.

TX25  
1pc.

TX30  
1pc.

TX40  
1pc.

COD. **66002130**  
€ 15,400



PH1  
1pc.



PH2  
1pc.



PZ1  
1pc.

PZ2  
1pc.

TX15  
1pc.

TX20  
1pc.

66002

DISPLAY MYBIT 7  
TITANIUM

ESPOSITORE DA BANCO IN PLEXIGLASS PER 12 BIT-SETS  
12 PCS. BIT-SETS PLEXIGLASS COUNTER DISPLAY  
PRÉSENTOIR EN PLEXIGLASS POUR 12 JEUX D'EMBOUTS  
MOSTRADOR DE EXPOSICIÓN IN PLEXIGLASS PARA 12 BIT-SET



12  
pcs.

150 X 40 X 195 mm

COD. **66002113**  
€ 188,400



12 pcs.  
COD. 66002110

COD. **66002124**  
€ 210,000



12 pcs.  
COD. 66002120

COD. **66002134**  
€ 184,800



12 pcs.  
COD. 66002130





**66007**

**MYBIT 7 POWER**

ASSORTIMENTI TITANIUM

ASSORTIMENTO 7 PCS. - INSERTI  
7 PCS. SET - BITS  
JEU 7 PCS. - EMBOUTS  
JUEGO 7 PCS. - PUNTAS

**NEW!**



7  
pcs.

COD. **66007150**

€ 23,800

61451  L=50mm



PH1  
1pc.

PH2  
2pcs.

PH3  
1pc.

61461  L=50mm



PZ1  
1pc.

PZ2  
1pc.

PZ3  
1pc.



100 X 120 mm





# 1. LINEE PREMIUM

PREMIUM LINES  
LIGNES PREMIUM  
LÍNEAS PREMIUM

**66005**

**MYBIT 10**

ASSORTIMENTI TITANIUM

ASSORTIMENTO 10 PCS. - INSERTI + PORTAINSERI  
10 PCS. SET - BITS + BIT-HOLDER  
JEU 10 PCS. - EMBOUTS + PORTE-EMBOUTS  
JUEGO DE 10 PCS. - PUNTAS + PORTA PUNTAS



10  
pcs.



100 X 120 mm



INCLUSO / INCLUDED  
INCLUDE / INCLUIDO



COD. 62013005

COD. **66005110**

€ 20,700



PH1  
1pc.



PH2  
1pc.



PH3  
1pc.

PZ1  
1pc.

PZ2  
1pc.

PZ3  
1pc.

0,6x4,5  
1pc.

0,8x5,5  
1pc.

1,2x6,5  
1pc.

COD. **66005120**

€ 20,500



PH1  
1pc.



PH2  
1pc.



PH3  
1pc.

PZ1  
1pc.

PZ2  
1pc.

PZ3  
1pc.

TX25  
1pc.

TX30  
1pc.

TX40  
1pc.

COD. **66005130**

€ 21,800



PH1  
1pc.



PH2  
1pc.



PZ1  
1pc.

PZ2  
1pc.



TX25  
1pc.

TX30  
1pc.

0,6x4,5  
1pc.

0,8x5,5  
1pc.

1,2x6,5  
1pc.

**66005**

**DISPLAY MYBIT 10**  
TITANIUM

ESPOSITORE DA BANCO IN PLEXIGLASS PER 12 BIT-SETS  
12 PCS. BIT-SETS PLEXIGLASS COUNTER DISPLAY  
PRÉSENTOIR EN PLEXIGLASS POUR 12 JEUX D'EMBOUTS  
MOSTRADOR DE EXPOSICIÓN IN PLEXIGLASS PARA 12 BIT-SET



12  
pcs.

150 X 40 X 195 mm

COD. **66005114**

€ 248,400



12 pcs.  
COD. 66005110

COD. **66005124**

€ 246,000



12 pcs.  
COD. 66005120

COD. **66005134**

€ 261,600



12 pcs.  
COD. 66005130



66006

**MYBIT 15**

ASSORTIMENTI TITANIUM

ASSORTIMENTO 15 PCS. - INSERTI + PORTAINSERI  
15 PCS. SET - BITS + BIT-HOLDER  
JEU 15 PCS. - EMBOUTS + PORTE-EMBOUTS  
JUEGO DE 15 PCS. - PUNTAS + PORTA PUNTAS

15  
pcs.

100 X 167 mm



INCLUSO / INCLUDED  
INCLUDE / INCLUIDO  
COD. 62013005

COD. **66006040**

€ 30,900

61045



PH1

1pc.

PH2

1pc.

PH3

1pc.

PZ1

1pc.

61071



PZ2

1pc.

PZ3

1pc.

61095



TX20

1pc.

TX25

1pc.

TX30

1pc.

TX40

1pc.

61026



0,6x4,0

1pc.

0,8x5,5

1pc.

61052



PH2

1pc.

61078



PZ2

1pc.

66006

**DISPLAY MYBIT 15**  
TITANIUM

ESPOSITORE DA BANCO IN PLEXIGLASS PER 12 BIT-SETS  
12 PCS. BIT-SETS PLEXIGLASS COUNTER DISPLAY  
PRÉSENTOIR EN PLEXIGLASS POUR 12 JEUX D'EMBOUTS  
MOSTRADOR DE EXPOSICIÓN IN PLEXIGLASS PARA 12 BIT-SET

12  
pcs.

185 X 40 X 195 mm

COD. **66006044**

€ 370,800

12 pcs.  
COD. 66006040



# 1.1 LINEE PREMIUM

PREMIUM LINES  
LIGNES PREMIUM  
LÍNEAS PREMIUM

**66006**

## MYBIT 14 TITANIUM CON CRICCHETTO

ASSORTIMENTO 14 PCS. TITANIUM / CRICCHETTO  
14 PCS. SET - BITS + BIT HOLDER AND RATCHET  
JEU 14 PCS. - EMBOUTS + PORTE-EMBOUTS  
JUEGO DE 14 PCS. - PUNTAS + PORTA PUNTAS

**NEW!**

14  
pcs.

COD. **66006520**

€ 37,400



100 X 170 mm



61045			61071		
PH1	PH2	PH3	PZ1	PZ2	PZ3
1pc.	1pc.	1pc.	1pc.	1pc.	1pc.
61095				61026	
TX20	TX25	TX30	TX40	4x0,6	5,5x0,8
1pc.	1pc.	1pc.	1pc.	1pc.	1pc.

INCLUSO / INCLUDED  
INCLUDE / INCLUIDO

COD. 62013005



COD. 64221030



**66010**

## ASSORTIMENTI TITANIUM

ASSORTIMENTO 31 PCS. - INSERTI + PORTAININSERTI  
31 PCS. SET - BITS + BIT-HOLDER  
JEU 31 PCS. - EMBOUTS + PORTE-EMBOUTS  
JUEGO DE 31 PCS. - PUNTAS + PORTA PUNTAS

31  
pcs.

COD. **66010010**

€ 52,800



80 X 115 X 30 mm

61045			61071			
PH1	PH2	PH3	PZ1	PZ2	PZ3	
2pcs.	3pcs.	1pc.	2pcs.	3pcs.	1pc.	
61095						
TX10	TX15	TX20	TX25	TX27	TX30	TX40
2pcs.	2pcs.	2pcs.	2pcs.	2pcs.	2pcs.	2pcs.
61026						
0,5x3,0	0,6x4,0	0,8x5,5	1,2x6,5			
1pc.	1pc.	1pc.	1pc.			

INCLUSO / INCLUDED  
INCLUDE / INCLUIDO  
COD. 62013005



**66001****STORE 9**

ASSORTIMENTI TITANIUM

CASSETTIERA CON 9 SCOMPARTI PER ESPOSITORE MULTISTORE  
 DRAWERS WITH 9 COMPARTMENTS FOR MULTISTORE DISPLAY  
 TIROIRS AVEC 9 COMPARTIMENTS POUR PRESENTOIR MULTISTORE  
 9 CAJONES PARA MOSTRADOR DE EXPOSICIÓN TIPO MULTISTORE

150  
pcs.

600 X 90 X 65 mm

COD. **66001050**

€ 208,000

61045		61071		61095			61026	
PH1	PH2	PZ1	PZ2	TX25	TX30	TX40	0,6x4,0	1,2x6,5
20pcs.	30pcs.	20pcs.	30pcs.	10pcs.	10pcs.	10pcs.	10pcs.	10pcs.

COD. **66001051**

€ 206,000

61045		61071		61095				
PH1	PH2	PZ1	PZ2	TX15	TX20	TX25	TX30	TX40
20pcs.	30pcs.	20pcs.	30pcs.	10pcs.	10pcs.	10pcs.	10pcs.	10pcs.

**MULTI STORE**

COD. 66001005VC

PER DETAGLI E COMPOSIZIONE VEDERE P. 184  
 FOR DETAILS AND COMPOSITION SEE P. 184  
 POUR LES DÉTAILS ET LA COMPOSITION VOIR P. 184  
 PARA MÁS DETALLES Y COMPOSICIÓN VÉASE P. 184



# 1.1 LINEE PREMIUM

PREMIUM LINES  
LIGNES PREMIUM  
LÍNEAS PREMIUM

66001

**MULTI BIT**

ESPOSITORE INSERTI TITANIUM

ESPOSITORE DA BANCO CON 25 SCOMPARTI  
COUNTER DISPLAY WITH 25 COMPARTMENTS  
PRÉSENTOIR DE COMPTOIR À 25 LOGEMENTS  
MOSTRADOR DE EXPOSICIÓN DE 25 ALOJAMIENTOS

270  
pcs.



COD. **66001325**

€ 723,000

61045



PH1 10pcs.	PH2 20pcs.	PH3 10pcs.
---------------	---------------	---------------

61071



PZ1 10pcs.	PZ2 20pcs.	PZ3 10pcs.
---------------	---------------	---------------

61095



TX10 10pcs.	TX15 10pcs.	TX20 10pcs.	TX25 10pcs.	TX27 10pcs.	TX30 10pcs.	TX40 10pcs.
----------------	----------------	----------------	----------------	----------------	----------------	----------------

61052



PH1 10pcs.	PH2 10pcs.	PH3 10pcs.
---------------	---------------	---------------

61078



PZ1 10pcs.	PZ2 10pcs.	PZ3 10pcs.
---------------	---------------	---------------

61026



0,5x3,0 10pcs.	0,6x4,0 10pcs.	0,6x4,5 10pcs.	0,8x5,5 10pcs.	1,2x6,5 10pcs.
-------------------	-------------------	-------------------	-------------------	-------------------

62015010



10pcs.

445 X 465 X 210 mm

STRUTTURA IN POLIPROPILENE ALVEOLARE AUTOPORTANTE, 25 SCOMPARTI.  
SELF-SUPPORTING POLYPROPYLENE HONEYCOMB STRUCTURE, 25 COMPARTMENTS.  
STRUCTURE EN POLYPROPYLÈNE ALVÉOLAIRE AUTOPORTANTE, 25 LOGEMENTS.  
ESTRUCTURA DE POLIPROPILENO ALVEOLAR AUTOSUSTENTADA, 25 ALOJAMIENTOS.

**66001****MULTI BOX****ESPOSITORE MINIBOX TITANIUM**

ESPOSITORE DA BANCO IN FILO METALLICO PER MINIBOX  
 METAL WIRE COUNTER DISPLAY FOR MINIBOX  
 PRÉSENTOIR DE COMPTOIR EN FIL MÉTALLIQUE POUR MINIBOX  
 MOSTRADOR DE EXPOSICIÓN DE ALAMBRE PARA MINIBOX

**550  
pcs.**COD. **66001520****€ 1'037,000**

			L mm	COD.	box	
	10 pcs.		<b>PH1</b>	25	61045005010	4
	10 pcs.		<b>PH2</b>	25	61045015010	5
	10 pcs.		<b>PH3</b>	25	61045020010	3
	10 pcs.		<b>PZ1</b>	25	61071005010	4
	10 pcs.		<b>PZ2</b>	25	61071010010	5
	10 pcs.		<b>PZ3</b>	25	61071015010	3
	10 pcs.		<b>0,6x4,0</b>	25	61026005010	2
	10 pcs.		<b>0,8x5,5</b>	25	61026010010	2
	10 pcs.		<b>1,2x6,5</b>	25	61026015010	2
	10 pcs.		<b>TX15</b>	25	61095010010	3
	10 pcs.		<b>TX20</b>	25	61095015010	3
	10 pcs.		<b>TX25</b>	25	61095020010	3
	10 pcs.		<b>TX30</b>	25	61095030010	3
	10 pcs.		<b>TX40</b>	25	61095035010	3
	5 pcs.		<b>PH1</b>	50	61052005005	3
	5 pcs.		<b>PH2</b>	50	61052010005	3
	5 pcs.		<b>PH3</b>	50	61052015005	3
	5 pcs.		<b>PZ1</b>	50	61078005005	3
	5 pcs.		<b>PZ2</b>	50	61078010005	3
	5 pcs.		<b>PZ3</b>	50	61078015005	3
	1 pc.				62020010001	5
	1 pc.				62015010001	5

**370 X 545 X 220 mm**

STRUTTURA IN FILO METALLICO DA BANCO ED APPENDIBILE ADATTA AD ACCOGLIERE 20 MISURE DIVERSE DI INSERTI CONFEZIONATI IN MINIBOX E DUE ARTICOLI ACCESSORI.

COUNTERTOP OR WALL-MOUNTED METAL WIRE STRUCTURE, SUITABLE FOR HOLDING BITS IN 20 DIFFERENT SIZES, MINIBOX PACKED AND TWO ACCESSORIES.

STRUCTURE EN FIL MÉTALLIQUE DE COMPTOIR ET À SUSPENDRE, ADAPTÉE POUR 20 TAILLES DIFFÉRENTES D'EMBOÛTS EMBALLÉS DANS UNE MINI-BOÎTE ET DEUX ARTICLES ACCESSOIRES.

ESTRUCTURA DE HILO METÁLICO PARA MOSTRADOR QUE SE PUEDE COLGAR APTA PARA ALOJAR 20 DIFERENTES MEDIDAS DE PUNTAS PUESTOS EN MINICAJAS MÁS DOS ARTÍCULOS DE ACCESORIOS.

# INX



## INSERTI 1/4" REALIZZATI IN ACCIAIO INOX

1/4" stainless steel bits

Embouts 1/4" réalisés en acier inoxydable

puntas de 1/4" fabricados con acero inoxidable



### RESISTENZA ALLA CORROSIONE IN ATMOSFERA SALINA

Resistance to corrosion in saline atmospheres / résistance à la corrosion en atmosphère saline / resistencia a la corrosión en atmósfera salina

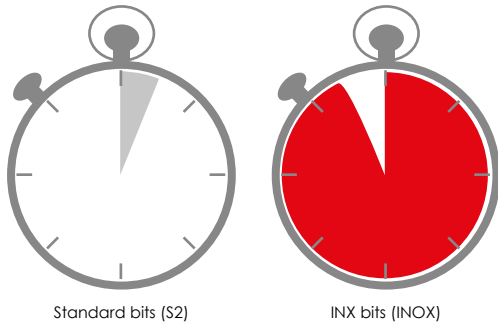

### RAPPORTO RESISTENZA ALL'USURA-RINVENIMENTO CRIOGENICO

Wear resistance-cryogenic recovery ratio / rapport résistance à l'usure-revenu cryogénique / relación resistencia al desgaste-revenimiento criogénico

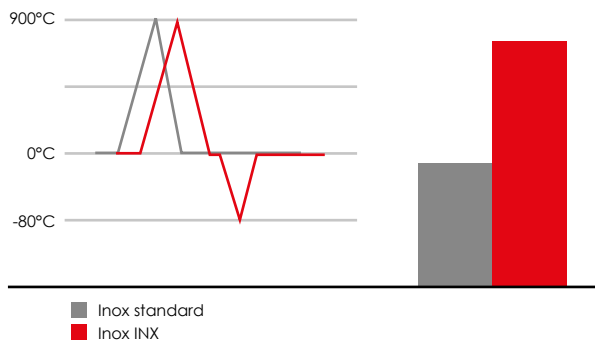

Applicazioni  
applications  
aplicaciones

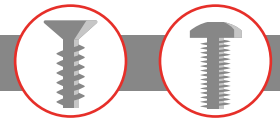

Interamente realizzati in acciaio inossidabile.

Made entirely of stainless steel.

Entièrement réalisées en acier inoxydable.

Completamente realizados con acero inoxidable.



Per lavori in condizioni estreme: resistono alla corrosione anche a contatto con acqua di mare.

For extreme conditions applications: corrosion resistant, even in contact with seawater.

Pour des travaux dans des conditions extrêmes : elles résistent à la corrosion même en contact avec l'eau de mer.

Para trabajos en condiciones difíciles: resistentes a la corrosión, incluso en contacto con el agua del mar.



Indicati per l'uso con viteria INOX in quanto non provocano / innescano ossidazioni.

Suitable for use with stainless steel screws as they do not cause or generate oxidation.

Indiquées pour l'utilisation avec vis INOX car elles ne provoquent pas et ne déclenchent pas d'oxydations.

Indicados para ser usados con tornillos INOX considerado que no provocan / causan oxidaciones.



**61410****PH INX**

INSERTI 1/4" C PHILLIPS® - IN ACCIAIO INOX  
 1/4" C PHILLIPS® BITS - IN STAINLESS STEEL  
 EMBOUTS 1/4 "C PHILLIPS® - EN ACIER INOX  
 PUNTAS DE 1/4" C PHILLIPS® - DE ACERO INOXIDABLE

54/56 HRC

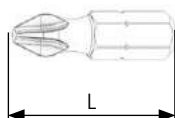
**EASYPACK** | sacchetto PVC con Euro-hole • PVC bags with Euro-hole

	L mm	PCS.	COD.	€ cad./each
<b>PH1</b>	25	10	61410005	2,280
<b>PH2</b>	25	10	61410010	2,280
<b>PH3</b>	25	10	61410015	2,280

**SELPACK**  
2 pcs.

	L mm	COD.	€ box
<b>PH1</b>	25	61410005002	5,900
<b>PH2</b>	25	61410010002	5,900
<b>PH3</b>	25	61410015002	5,900

**MINIBOX**  
10 pcs.

	L mm	COD.	€ box
<b>PH1</b>	25	61410005010	23,900
<b>PH2</b>	25	61410010010	23,900
<b>PH3</b>	25	61410015010	23,900

**61420****PZ INX**

INSERTI 1/4" C POZIDRIV® - IN ACCIAIO INOX  
 1/4" C POZIDRIV® BITS - IN STAINLESS STEEL  
 EMBOUTS 1/4 "C POZIDRIV® - EN ACIER INOX  
 PUNTAS DE 1/4" C POZIDRIV® - DE ACERO INOXIDABLE

54/56 HRC

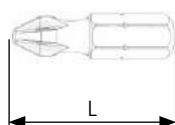
**EASYPACK** | sacchetto PVC con Euro-hole • PVC bags with Euro-hole

	L mm	PCS.	COD.	€ cad./each
<b>PZ1</b>	25	10	61420005	2,280
<b>PZ2</b>	25	10	61420010	2,280
<b>PZ3</b>	25	10	61420015	2,280

**SELPACK**  
2 pcs.

	L mm	COD.	€ box
<b>PZ1</b>	25	61420005002	5,900
<b>PZ2</b>	25	61420010002	5,900
<b>PZ3</b>	25	61420015002	5,900

**MINIBOX**  
10 pcs.

	L mm	COD.	€ box
<b>PZ1</b>	25	61420005010	23,900
<b>PZ2</b>	25	61420010010	23,900
<b>PZ3</b>	25	61420015010	23,900



# 1.1 LINEE PREMIUM

PREMIUM LINES  
LIGNES PREMIUM  
LÍNEAS PREMIUM

**61430**

TX INX



INSERTI 1/4" C PER VITI TORX® - IN ACCIAIO INOX  
1/4" C BITS FOR TORX® SCREWS - IN STAINLESS STEEL  
EMBOUS 1/4" C POUR VIS TORX® - EN ACIER INOX  
PUNTAS DE 1/4" C PARA TORNILLOS TORX® - DE ACERO INOXIDABLE

54/56 HRC

**EASYPACK** | sacchetto PVC con Euro-hole • PVC bags with Euro-hole

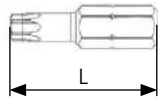

	L mm	PCS.	COD.	€ cad./each
<b>TX10</b>	25	10	61430005	2,550
<b>TX15</b>	25	10	61430010	2,550
<b>TX20</b>	25	10	61430015	2,550
<b>TX25</b>	25	10	61430020	2,550
<b>TX30</b>	25	10	61430030	2,550
<b>TX40</b>	25	10	61430035	2,550

	L mm	COD.	€ box
<b>TX10</b>	25	61430005002	6,430
<b>TX15</b>	25	61430010002	6,430
<b>TX20</b>	25	61430015002	6,430
<b>TX25</b>	25	61430020002	6,430
<b>TX30</b>	25	61430030002	6,430
<b>TX40</b>	25	61430035002	6,430



**SELPACK**  
2 pcs.

	L mm	COD.	€ box
<b>TX10</b>	25	61430005010	26,700
<b>TX15</b>	25	61430010010	26,700
<b>TX20</b>	25	61430015010	26,700
<b>TX25</b>	25	61430020010	26,700
<b>TX30</b>	25	61430030010	26,700
<b>TX40</b>	25	61430035010	26,700



**MINIBOX**  
10 pcs.

**61400**

HEX INX



INSERTI 1/4" C ESAGONALI - IN ACCIAIO INOX  
1/4" C HEX BITS - IN STAINLESS STEEL  
EMBOUS 1/4" C 6 PANS - EN ACIER INOX  
PUNTAS DE 1/4" C HEXAGONALES - DE ACERO INOXIDABLE

54/56 HRC

**EASYPACK** | sacchetto PVC con Euro-hole • PVC bags with Euro-hole

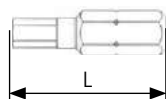

	L mm	PCS.	COD.	€ cad./each
<b>2</b>	25	10	61400005	2,820
<b>2,5</b>	25	10	61400010	2,820
<b>3</b>	25	10	61400015	2,820
<b>4</b>	25	10	61400020	2,820
<b>5</b>	25	10	61400025	2,820
<b>6</b>	25	10	61400030	2,820

	L mm	COD.	€ box
<b>2</b>	25	61400005002	6,970
<b>2,5</b>	25	61400010002	6,970
<b>3</b>	25	61400015002	6,970
<b>4</b>	25	61400020002	6,970
<b>5</b>	25	61400025002	6,970
<b>6</b>	25	61400030002	6,970



**SELPACK**  
2 pcs.

	L mm	COD.	€ box
<b>2</b>	25	61400005010	29,500
<b>2,5</b>	25	61400010010	29,500
<b>3</b>	25	61400015010	29,500
<b>4</b>	25	61400020010	29,500
<b>5</b>	25	61400025010	29,500
<b>6</b>	25	61400030010	29,500



**MINIBOX**  
10 pcs.

**61405** TAGLIO INX 

INSERTI 1/4" C A TAGLIO - IN ACCIAIO INOX  
 1/4" C SLOTTED BITS - IN STAINLESS STEEL  
 EMBOUTS 1/4 "C À FENTE - EN ACIER INOX  
 PUNTAS DE 1/4" C DE CORTE - DE ACERO INOXIDABLE

54/56 HRC

EASYPACK | sacchetto PVC con Euro-hole • PVC bags with Euro-hole

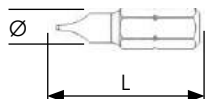

	Ø mm	L mm	PCS.	COD.	€ cad./each
0,5	3	25	10	61405005	2,950
0,6	4	25	10	61405010	2,950
0,6	4,5	25	10	61405015	2,950
0,8	5,5	25	10	61405020	2,950
1,2	6,5	25	10	61405025	2,950

	Ø mm	L mm	COD.	€ box
0,5	3	25	61405005002	7,230
0,6	4	25	61405010002	7,230
0,6	4,5	25	61405015002	7,230
0,8	5,5	25	61405020002	7,230
1,2	6,5	25	61405025002	7,230



SELPACK  
2 pcs.



MINIBOX  
10 pcs.

	Ø mm	L mm	COD.	€ box
0,5	3	25	61405005010	31,000
0,6	4	25	61405010010	31,000
0,6	4,5	25	61405015010	31,000
0,8	5,5	25	61405020010	31,000
1,2	6,5	25	61405025010	31,000



Bacino di carenaggio di un cantiere navale.  
 Dry dock of a shipyard.  
 Cale sèche de chantier naval.  
 Dique seco de un astillero.



# 1.1 LINEE PREMIUM

PREMIUM LINES  
LIGNES PREMIUM  
LÍNEAS PREMIUM

**62015**

**PORTAINSERTI INX**



PORTAINSERTI 1/4"E IN ACCIAIO INOX INTEGRALE MAGNETICO CON ANELLO PER INSERTI 1/4"C  
1/4"E STAINLESS STEEL BIT HOLDER WITH C-RING AND MAGNET FOR 1/42C BITS  
PORTEBOUITS 1/4" EN ACIER INOXYDABLE MAGNETIQUE AVEC BAGUE C POUR EMOUBITS 1/4"C  
PORTA PUNTAS DE 1/4"E EN ACERO INOXIDABLE MAGNETICO CON ANILLO C PARA PUNTAS 1/4"C

**NEW!**

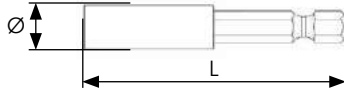
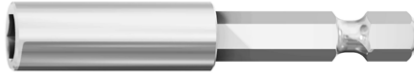

**EASYPACK** | sacchetto PVC con Euro-hole • PVC bags with Euro-hole

L mm	Ø mm	PCS.	COD.	€ cad./each
60	11	5	62015105	7,100



**SELPACK**  
1 pc.

L mm	COD.	€ box
60	62015105001	8,390

**62016**

**PORTAINSERTI INX  
MANDRINO DI BLOCCO**



PORTAINSERTI 1/4"E IN ACCIAIO INOX MAGNETICO CON MANDRINO DI BLOCCO  
1/4"E STAINLESS STEEL BIT HOLDER WITH LOCK CHUCK AND MAGNET  
PORTEBOUITS 1/4" EN ACIER INOX MAGNETIQUE AVEC MANDRIN DE BLOQUE  
PORTA PUNTAS DE 1/4"E EN ACERO INOX MAGNETICO CON MANDRIL DE BLOQUEO

**NEW!**

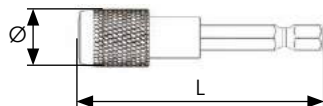

**EASYPACK** | sacchetto PVC con Euro-hole • PVC bags with Euro-hole

L mm	Ø mm	PCS.	COD.	€ cad./each
60	14	5	62016105	9,240



**SELPACK**  
1 pc.

L mm	COD.	€ box
60	62016105001	10,600



**FOCUS ON**



Le sfere di tenuta bloccano l'inserto: questo articolo è consigliato per l'uso con inserti esagonali che tendono a bloccarsi nella cava della vite.

The sealing balls block the bit: this article is recommended for use with hexagon bits that tend to become blocked in the slot of the screw.

Les billes bloquent l'embout : cet article est recommandé lors de l'utilisation d'embouts hexagonaux qui ont tendance à se coincer dans la fente de la vis.

Las esferas de retención bloquean la punta: este artículo se aconseja para que se use con puntas hexagonales que tienden a bloquearse en la ranura del tornillo.





66002

# MYBIT 7 ASSORTIMENTI INX

ASSORTIMENTO 7 PCS. - INSERTI + PORTAINSERI  
7 PCS. SET - BITS + BIT-HOLDER  
JEU 7 PCS. - EMBOUTS + PORTE-EMBOUTS  
JUEGO DE 7 PCS. - PUNTAS + PORTA PUNTAS



7  
pcs.



100 X 120 mm



INCLUSO / INCLUDED  
INCLUSE / INCLUIDO  
COD. 62015105



COD. **66002400**  
€ 23,900



PH1  
1pc.



PH2  
1pc.

PZ1  
1pc.

PZ2  
1pc.

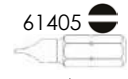

0,6x4,5  
1pc.

1,2x6,5  
1pc.

COD. **66002405**  
€ 24,200



TX10  
1pc.

TX15  
1pc.

TX20  
1pc.

TX25  
1pc.

TX30  
1pc.

TX40  
1pc.

COD. **66002410**  
€ 23,200



PH1  
1pc.

PH2  
1pc.

PZ1  
1pc.

PZ2  
1pc.



TX25  
1pc.

TX30  
1pc.

66002

# DISPLAY MYBIT 7 INX

ESPOSITORE DA BANCO IN PLEXIGLASS PER 12 BIT-SETS  
12 PCS. BIT-SETS PLEXIGLASS COUNTER DISPLAY  
PRÉSENTOIR EN PLEXIGLASS POUR 12 JEUX D'EMBOUTS  
MOSTRADOR DE EXPOSICIÓN IN PLEXIGLASS PARA 12 BIT-SET



12  
pcs.

150 X 40 X 195 mm

COD. **66002404**  
€ 286,800



12 pcs.  
COD. 66002400

COD. **66002409**  
€ 290,400



12 pcs.  
COD. 66002405

COD. **66002414**  
€ 278,400



12 pcs.  
COD. 66002410



# 1.1 LINEE PREMIUM

PREMIUM LINES  
LIGNES PREMIUM  
LÍNEAS PREMIUM

**66005**

**MYBIT 10**

ASSORTIMENTI INX

ASSORTIMENTO 10 PCS. - INSERTI + PORTAINSERI  
10 PCS. SET - BITS + BIT-HOLDER  
JEU 10 PCS. - EMBOUTS + PORTE-EMBOUTS  
JUEGO DE 10 PCS. - PUNTAS + PORTA PUNTAS



10  
pcs.

COD. **66005400**

€ 30,700

61410			61420			61405		
PH1	PH2	PH3	PZ1	PZ2	PZ3	0,6x4,5	0,8x5,5	1,2x6,5
1pc.	1pc.	1pc.	1pc.	1pc.	1pc.	1pc.	1pc.	1pc.

COD. **66005405**

€ 29,700

61410			61420			61430		
PH1	PH2	PH3	PZ1	PZ2	PZ3	TX25	TX30	TX40
1pc.	1pc.	1pc.	1pc.	1pc.	1pc.	1pc.	1pc.	1pc.

COD. **66005410**

€ 30,800

61410		61420		61430		61400		
PH2	PH3	PZ2	PZ3	TX20	TX25	4	5	6
1pc.	1pc.	1pc.	1pc.	1pc.	1pc.	1pc.	1pc.	1pc.

INCLUSO / INCLUDED  
INCLUSE / INCLUIDO

COD. 62015105



100 X 120 mm

**66005**

**DISPLAY MYBIT 10**  
INX

ESPOSITORE DA BANCO IN PLEXIGLASS PER 12 BIT-SETS  
12 PCS. BIT-SETS PLEXIGLASS COUNTER DISPLAY  
PRÉSENTOIR EN PLEXIGLASS POUR 12 JEUX D'EMBOUTS  
MOSTRADOR DE EXPOSICIÓN IN PLEXIGLASS PARA 12 BIT-SET



12  
pcs.

COD. **66005404**

€ 368,400



12 pcs.  
COD. 66005400

COD. **66005409**

€ 356,400



12 pcs.  
COD. 66005405

COD. **66005414**

€ 369,600



12 pcs.  
COD. 66005410

150 X 40 X 195 mm



## 66006 MYBIT 14 INX CON CRICCHETTO

ASSORTIMENTO 14 PCS. INX / CRICCHETTO  
14 PCS. SET - BITS + BIT HOLDER AND RATCHET  
JEU 14 PCS. - EMOBOUTS + PORTE-EMOUBOTS  
JUEGO DE 14 PCS. - PUNTAS + PORTA PUNTAS

### NEW!

COD. **66006525**

€ 43,200



14  
pcs.



100 X 170 mm



61410			61420		
PH1	PH2	PH3	PZ1	PZ2	PZ3
1pc.	1pc.	1pc.	1pc.	1pc.	1pc.

61430			61405		
TX25	TX30	TX40	0,6x4,5	0,8x5,5	1,2x6,5
1pc.	1pc.	1pc.	1pc.	1pc.	1pc.

INCLUSO / INCLUDED  
INCLUDE / INCLUIDO

COD. 62015105

COD. 64221030



## 66010 ASSORTIMENTI INX

ASSORTIMENTO 31 PCS. - INSERTI + PORTAININSERTI  
31 PCS. SET - BITS + BIT-HOLDER  
JEU 31 PCS. - EMOBOUTS + PORTE-EMOUBOTS  
JUEGO DE 31 PCS. - PUNTAS + PORTA PUNTAS

COD. **66010045**

€ 78,800



31  
pcs.



80 X 115 X 30 mm

61410			61420		
PH1	PH2	PH3	PZ1	PZ2	PZ3
2pcs.	2pcs.	2pcs.	2pcs.	2pcs.	2pcs.

61430				61405		
TX20	TX25	TX30	TX40	0,6x4,0	0,8x5,5	1,2x6,5
2pcs.	2pcs.	2pcs.	1pc.	1pc.	1pc.	1pc.

61400			
3	4	5	6
2pcs.	2pcs.	2pcs.	2pcs.

INCLUSO / INCLUDED  
INCLUDE / INCLUIDO

COD. 62015105





# 1.1 LINEE PREMIUM

PREMIUM LINES  
LIGNES PREMIUM  
LÍNEAS PREMIUM

**66001**

**STORE 9**

ASSORTIMENTI INX

CASSETTIERA CON 9 SCOMPARTI PER ESPOSITORE MULTISTORE  
DRAWERS WITH 9 COMPARTMENTS FOR MULTISTORE DISPLAY  
TIROIRS AVEC 9 COMPARTIMENTS POUR PRESENTOIR MULTISTORE  
9 CAJONES PARA MOSTRADOR DE EXPOSICIÓN TIPO MULTISTORE



110  
pcs.

600 X 90 X 65 mm

COD. **66001075**

€ 214,000

61410		61420		61400			61405	
PH1	PH2	PZ1	PZ2	3	4	5	0,8x5,5	1,2x6,5
10pcs.	20pcs.	10pcs.	20pcs.	10pcs.	10pcs.	10pcs.	10pcs.	10pcs.

COD. **66001076**

€ 198,000

61410		61420			61430			
PH1	PH2	PH3	PZ1	PZ2	PZ3	TX20	TX25	TX30
10pcs.	20pcs.	10pcs.	10pcs.	20pcs.	10pcs.	10pcs.	10pcs.	10pcs.



## MULTI STORE

COD. 66001005VC

PER DETTAGLI E COMPOSIZIONE VEDERE P. 184  
FOR DETAILS AND COMPOSITION SEE P. 184  
POUR LES DÉTAILS ET LA COMPOSITION VOIR P. 184  
PARA MÁS DETALLES Y COMPOSICIÓN VÉASE P. 184



**66001****MULTI BIT**  
ESPOSITORE INSERTI INXESPOSITORE DA BANCO CON 25 SCOMPARTI  
COUNTER DISPLAY WITH 25 COMPARTMENTS  
PRÉSENTOIR DE COMPTOIR À 25 LOGEMENTS  
MOSTRADOR DE EXPOSICIÓN DE 25 ALOJAMIENTOS265  
pcs.

445 X 465 X 210 mm

STRUTTURA IN POLIPROPILENE ALVEOLARE AUTOPORTANTE, 25 SCOMPARTI.  
SELF-SUPPORTING POLYPROPYLENE HONEYCOMB STRUCTURE, 25 COMPARTMENTS.  
STRUCTURE EN POLYPROPYLÈNE ALVÉOLAIRE AUTOPORTANTE, 25 LOGEMENTS.  
ESTRUCTURA DE POLIPROPILENO ALVEOLAR AUTOSUSTENTADA, 25 ALOJAMIENTOS.COD. **66001335**

€ 580,000

61410			61420		
PH1 10pcs.	PH2 20pcs.	PH3 10pcs.	PZ1 10pcs.	PZ2 20pcs.	PZ3 10pcs.
61430					
TX10 10pcs.	TX15 10pcs.	TX20 10pcs.	TX25 10pcs.	TX30 10pcs.	TX40 10pcs.
61400					
2 10pcs.	2,5 10pcs.	3 10pcs.	4 10pcs.	5 10pcs.	6 10pcs.
61405					
0,5x3,0 10pcs.	0,6x4,0 10pcs.	0,6x4,5 10pcs.	0,8x5,5 10pcs.	1,2x6,5 10pcs.	
62025010			62015105		
5pcs.			10pcs.		



# 1. LINEE PREMIUM

PREMIUM LINES  
LIGNES PREMIUM  
LÍNEAS PREMIUM

66001

**MULTIBOX**

ESPOSITORE MINIBOX INX

ESPOSITORE DA BANCO IN FILO METALLICO PER MINIBOX  
METAL WIRE COUNTER DISPLAY FOR MINIBOX  
PRÉSENTOIR DE COMPTOIR EN FIL MÉTALLIQUE POUR MINIBOX  
MOSTRADOR DE EXPOSICIÓN DE ALAMBRE PARA MINIBOX



428  
pcs.

COD. **66001530**  
€ 967,000

			L mm	COD.	box
10 pcs.		<b>PH1</b>	25	61410005010	2
10 pcs.		<b>PH2</b>	25	61410010010	3
10 pcs.		<b>PH3</b>	25	61410015010	2
10 pcs.		<b>PZ1</b>	25	61420005010	2
10 pcs.		<b>PZ2</b>	25	61420010010	3
10 pcs.		<b>PZ3</b>	25	61420015010	2
10 pcs.		<b>TX15</b>	25	61430010010	2
10 pcs.		<b>TX20</b>	25	61430015010	2
10 pcs.		<b>TX25</b>	25	61430020010	2
10 pcs.		<b>TX30</b>	25	61430030010	2
10 pcs.		<b>TX40</b>	25	61430035010	2
10 pcs.		<b>2,5</b>	25	61400010010	2
10 pcs.		<b>3</b>	25	61400015010	2
10 pcs.		<b>4</b>	25	61400020010	2
10 pcs.		<b>5</b>	25	61400025010	2
10 pcs.		<b>6</b>	25	61400030010	2
10 pcs.		<b>0,6x4,0</b>	25	61405010010	2
10 pcs.		<b>0,6x4,5</b>	25	61405015010	2
10 pcs.		<b>0,8x5,5</b>	25	61405020010	2
10 pcs.		<b>1,2x6,5</b>	25	61405025010	2
1 pc.				62015105001	5
1 pc.				64221020	3



370 X 545 X 220 mm

STRUTTURA IN FILO METALLICO DA BANCO ED APPENDIBILE ADATTA AD ACCOGLIERE 20 MISURE DIVERSE DI INSERTI CONFEZIONATI IN MINIBOX E DUE ARTICOLI ACCESSORI.

COUNTERTOP OR WALL-MOUNTED METAL WIRE STRUCTURE, SUITABLE FOR HOLDING BITS IN 20 DIFFERENT SIZES, MINIBOX PACKED AND TWO ACCESSORIES.

STRUCTURE EN FIL MÉTALLIQUE DE COMPTOIR ET À SUSPENDRE, ADAPTÉE POUR 20 TAILLES DIFFÉRENTES D'EMBOÛTS EMBALLÉS DANS UNE MINI-BOÎTE ET DEUX ARTICLES ACCESSOIRES.

ESTRUCTURA DE HILO METÁLICO PARA MOSTRADOR QUE SE PUEDE COLGAR APTA PARA ALOJAR 20 DIFERENTES MEDIDAS DE PUNTAS PUESTOS EN MINICAJAS MÁS DOS ARTÍCULOS DE ACCESORIOS.



# FOCUS ON

## CORROSIONE

CORROSION  
CORROSION  
CORROSIÓN

1.1

New



### CORROSIONE

Gli acciai INOX sono leghe di ferro caratterizzate, oltre che dalle proprietà meccaniche tipiche degli acciai al carbonio, da una notevole resistenza alla corrosione. Tale capacità è dovuta alla presenza di elementi di lega, principalmente cromo, in grado di ricoprirsi di uno strato di ossidi aderente e invisibile che protegge il metallo sottostante dall'azione degli agenti chimici esterni (acqua, sale, altri metalli...).

I principali tipi di corrosione a cui è soggetto l'acciaio INOX sono quella in ambiente salino (corrosione salina) oppure quella dovuta a contaminazione da altri metalli (corrosione galvanica). Proprio per quest'ultimo motivo è preferibile utilizzare gli inserti INOX con viteria INOX o, se ciò non fosse possibile, interporre del materiale isolante tra gli stessi.

### CORROSION

*Stainless steels are iron alloys characterised not only by the typical mechanical properties of carbon steel, but also by a remarkable resistance to corrosion. This ability comes from the presence of alloy elements, primarily chromium, which are able to cover themselves with an adhering and invisible oxide layer that protects the underlying metal against the action of external chemical agents (water, salt, other metals, etc.).*

*STAINLESS steel is particularly prone to corrosion in saline environments (saline corrosion) or corrosion caused by contamination with other metals (galvanic corrosion).*

*For this last reason, it is preferable to use STAINLESS STEEL BITS with STAINLESS STEEL screws or, if this is not possible, to place insulating material between them.*



*Camera per test corrosione INOX in nebbia salina.*

*Chamber for STAINLESS STEEL corrosion tests in a saline mist.*

*Chambre pour test à la corrosion INOX en brouillard salin.*

*Cámara para la prueba de corrosión INOX en niebla salina.*

### CORROSION

*Les aciers INOX sont des alliages en fer qui se distinguent par leurs propriétés mécaniques typiques des aciers au carbone, et offrent une résistance élevée à la corrosion. Cette capacité est due à la présence d'éléments d'alliage, du chrome principalement, en mesure de se recouvrir d'une couche d'oxydes adhérente et invisible, qui protège le métal en dessous de l'action des agents chimiques externes (eau, sel, autres métaux, etc.).*

*Les principaux types de corrosion auxquels est sujet l'acier INOX sont ceux en environnement salin (corrosion saline) ou ceux dus à la contamination d'autres métaux (corrosion galvanique).*

*C'est précisément pour cette raison qu'il est préférable d'utiliser des embouts INOX avec vis INOX ou, si cela n'est pas possible, interposer du matériau isolant entre ces dernières.*

### CORROSIÓN

*Los aceros INOX son aleaciones de hierro que, además de tener propiedades mecánicas típicas de los aceros de carbono, se caracterizan por su elevada resistencia a la corrosión. Dicha capacidad se debe a la presencia de elementos de aleación, principalmente el cromo, capaces de cubrirse de una capa de óxidos adherente e invisible que protege al metal por debajo de la acción de los agentes químicos externos (agua, sal, otros metales...).*

*Los principales tipos de corrosión a los que está sometido el acero INOX son la corrosión en ambiente salino (corrosión salina) o la que se debe a la contaminación por otros metales (corrosión galvánica)*

*Justo por este último motivo es preferible usar los PUNTAS INOX con tornillos INOX o, si esto no fuera posible, interponer material aislante entre los mismos.*



*Esempio di corrosione galvanica dovuta dall'accoppiamento di dadi e bulloni in acciaio INOX su una piastra in acciaio.*

*Example of galvanic corrosion caused by combining stainless steel details on a steel plate.*

*Exemple de corrosion galvanique due au couplage d'écrous et boulons en acier INOX sur une plaque en acier.*

*Ejemplo de corrosión galvánica debida al acoplamiento de tuercas y pernos de acero INOX sobre una plancha de acero.*

# LTI®



## INSERTI 1/4" CON CRESTE ANTISCIVOLAMENTO

1/4" bits with Anti Come-out Ribs  
 Embouts 1/4" striures anti-dérapantes  
 Puntas 1/4" con crestas antideslizamiento

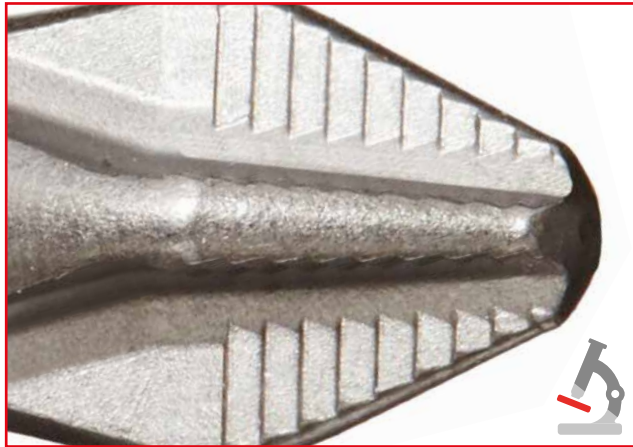

ACR® = creste antiscivolamento  
 ACR® = nonslip ridges  
 ACR® = striures antidérapantes  
 ACR® = crestas antideslizamiento



### RIDUZIONE DELL'EFFETTO COME-OUT

Reduced come-out effect / réduction de l'effet come-out / reducción del efecto de salida (come out)

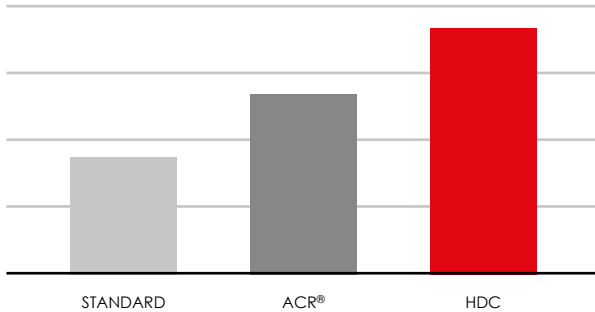

Applicazioni  
 applications  
 aplicaciones

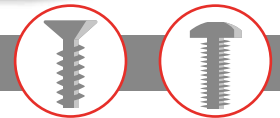

Ideali per applicazioni su materiali duri anche in presenza di ruggine: il sistema ACR® distribuisce più efficientemente la forza applicata.

*Ideal for applications using hard materials, even in the presence of rust: the ACR® system distributes the force applied in a more efficient way.*

*Idéal pour les applications sur des matériaux durs aussi en présence de rouille : le système ACR® distribue de façon plus efficace la force appliquée.*

*Ideales para aplicaciones sobre materiales duros incluso con óxido: el sistema ACR® distribuye de forma más eficaz la fuerza aplicada.*



Perfetta aderenza anche con viti verniciate o smaltate, tipiche del settore aeronautico.

*Perfect grip even with painted or enamelled screws typically used in the aviation industry.*

*Parfaite adhérence avec les vis peintes ou émaillées, typiques de l'industrie aéronautique.*

*Perfecta adherencia incluso con tornillos barnizados o esmaltados, típicos del sector aeronáutico.*



Le creste sulla punta dell'inserto aumentano l'aderenza nella cava della vite, riducendo lo scivolamento e il conseguente effetto come-out.

*The ridges on the tip of the bit increase grip in the cavity of the screw, reducing slippage and consequently, the come-out effect.*

*Les striures sur la pointe de l'embout augmentent l'adhérence dans le creux de la vis, en réduisant le glissement et l'effet de sortie qui en dérive.*

*Las crestas en la punta de la punta aumentan la adherencia en la ranura del tornillo, disminuyendo el deslizamiento y el consiguiente efecto come-out.*

**61049****PH ACR®**

INSERTI 1/4" C PHILLIPS® ACR  
 1/4" C PHILLIPS® ACR BITS  
 EMBOUTS 1/4" C PHILLIPS® ACR  
 PUNTAS DE 1/4" C PHILLIPS® ACR

58/60 HRC

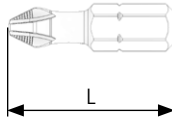
**EASYPACK** | sacchetto PVC con Euro-hole • PVC bags with Euro-hole

+	L mm	PCS.	COD.	€ cad./each
<b>PH1</b>	25	10	61049005	1,020
<b>PH2</b>	25	10	61049010	1,020
<b>PH3</b>	25	10	61049015	1,020

**SELPACK**  
2 pcs.

+	L mm	COD.	€ box
<b>PH1</b>	25	61049005002	3,380
<b>PH2</b>	25	61049010002	3,380
<b>PH3</b>	25	61049015002	3,380

**MINIBOX**  
10 pcs.

+	L mm	COD.	€ box
<b>PH1</b>	25	61049005010	11,600
<b>PH2</b>	25	61049010010	11,600
<b>PH3</b>	25	61049015010	11,600

**61060****PH ACR®**

LAME 1/4" E PHILLIPS® ACR  
 1/4" E PHILLIPS® ACR POWER BITS  
 EMBOUTS 1/4" E PHILLIPS® ACR  
 PUNTAS DE 1/4" E PHILLIPS® ACR

58/60 HRC

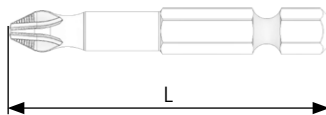
**EASYPACK** | sacchetto PVC con Euro-hole • PVC bags with Euro-hole

+	L mm	PCS.	COD.	€ cad./each
<b>PH1</b>	50	5	61060005	2,550
<b>PH2</b>	50	5	61060010	2,550
<b>PH3</b>	50	5	61060015	2,550

**SELPACK**  
2 pcs.

+	L mm	COD.	€ box
<b>PH1</b>	50	61060005002	6,430
<b>PH2</b>	50	61060010002	6,430
<b>PH3</b>	50	61060015002	6,430

**MINIBOX**  
5 pcs.

+	L mm	COD.	€ box
<b>PH1</b>	50	61060005005	13,400
<b>PH2</b>	50	61060010005	13,400
<b>PH3</b>	50	61060015005	13,400



# 1.1 LINEE PREMIUM

PREMIUM LINES  
LIGNES PREMIUM  
LÍNEAS PREMIUM

**61081**

PZ ACR®



INSERTI 1/4"C POZIDRIV® ACR  
1/4"C POZIDRIV® ACR BITS  
EMBOUTS 1/4"C POZIDRIV® ACR  
PUNTAS 1/4"C POZIDRIV® ACR

58/60 HRC

**EASYPACK** | sacchetto PVC con Euro-hole • PVC bags with Euro-hole

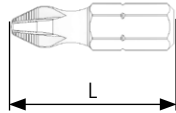

	L mm	PCS.	COD.	€ cad./each
<b>PZ1</b>	25	10	61081005	1,020
<b>PZ2</b>	25	10	61081010	1,020
<b>PZ3</b>	25	10	61081015	1,020



	L mm	COD.	€ box
<b>PZ1</b>	25	61081005002	3,380
<b>PZ2</b>	25	61081010002	3,380
<b>PZ3</b>	25	61081015002	3,380

**SELFPACK**  
2 pcs.



	L mm	COD.	€ box
<b>PZ1</b>	25	61081005010	11,600
<b>PZ2</b>	25	61081010010	11,600
<b>PZ3</b>	25	61081015010	11,600

**MINIBOX**  
10 pcs.

**61085**

PZ ACR®



LAME 1/4"E POZIDRIV® ACR  
1/4"E POZIDRIV® ACR POWER BITS  
EMBOUTS 1/4"E POZIDRIV® ACR  
PUNTAS DE 1/4"E POZIDRIV® ACR

58/60 HRC

**EASYPACK** | sacchetto PVC con Euro-hole • PVC bags with Euro-hole



	L mm	PCS.	COD.	€ cad./each
<b>PZ1</b>	50	5	61085005	2,550
<b>PZ2</b>	50	5	61085010	2,550
<b>PZ3</b>	50	5	61085015	2,550



	L mm	COD.	€ box
<b>PZ1</b>	50	61085005002	6,430
<b>PZ2</b>	50	61085010002	6,430
<b>PZ3</b>	50	61085015002	6,430

**SELFPACK**  
2 pcs.



	L mm	COD.	€ box
<b>PZ1</b>	50	61085005005	13,400
<b>PZ2</b>	50	61085010005	13,400
<b>PZ3</b>	50	61085015005	13,400

**MINIBOX**  
5 pcs.



# COME SCEGLIERE L'INSERTO PREMIUM



HOW TO CHOOSE THE RIGHT PREMIUM BIT  
COMMENT CHOISIR L'EMBOU PREMIUM  
CÓMO ESCOGER LA PUNTA PREMIUM

## VITI AUTOFILETTANTI PER LEGNO

Self-tapping screws for wood  
Vis autotaraudeuses pour bois  
Tornillos de rosca chapa para madera

**RECOMMENDED**

p. 76

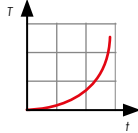

Lo sforzo cresce progressivamente fino al picco massimo quando la testa della vite penetra nel legno. In caso di legni duri questi sforzi possono essere elevati.

The stress grows progressively until reaching maximum peak when the head of the screw penetrates the wood. In case of hard wood, this stress can be very high.

La contrainte se développe progressivement jusqu'au pic maximum lorsque la tête de la vis pénètre dans le bois. Dans le cas de bois dur, ces contraintes peuvent être élevées.

El esfuerzo crece de forma progresiva hasta un punto máximo cuando la cabeza del tornillo penetra en la madera. En caso de madera dura, estos esfuerzos podrían ser muy elevados.

## VITI AUTO-FORANTI

Self-drilling screws  
Vis auto-perçuses  
Tornillos autotaladrantes

**RECOMMENDED**

p. 30

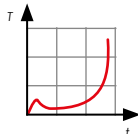

Nelle prime fasi si ha un picco di sforzo per la creazione di foro e filetto e le viti tendono a disallinearsi rischiando di rovonare il piano di avvitatura.

Given the particular use, when making the hole the screws tend to become misaligned and may ruin the material that is being worked.

Compte tenu de l'utilisation particulière, lors de la création du trou, les vis ont tendance à se désaligner en risquant d'abîmer le matériau travaillé.

Teniendo en cuenta el particular uso, durante la creación del orificio los tornillos tienden a desalinearse, arriesgando a estropear el material sobre el cual se está trabajando.

## VITI LUNGHE PER COPERTURE

Long screws for roofs  
Vis longues pour couvertures  
Tornillos largos para coberturas

**RECOMMENDED**

p. 76 p. 50

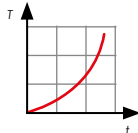

Durante la fase di avvitatura nel legno lo sforzo cresce repentinamente fino a raggiungere coppie estremamente elevate.

When screwing into wood, the stress increases until reaching extremely high torques.

Pendant la phase de vissage, la contrainte augmente jusqu'à atteindre des couples extrêmement élevés.

Durante la fase de atornillado en la madera, el esfuerzo crece hasta alcanzar par de torsión extremadamente altas.

T = TORSIONE - TORQUE

t = TEMPO - TIME

## VITI AUTOFILETTANTI PER METALLO

Self-tapping screws for metal  
Vis autotaraudeuses pour métal  
Tornillos de rosca chapa para metal

**RECOMMENDED**

p. 50 p. 64

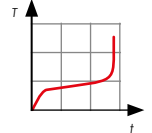

Lo sforzo, inizialmente elevato, diventa costante dopo la creazione del filetto, per poi raggiungere il picco al termine del lavoro.

The stress, initially high, becomes constant after the thread has been created, and then reaches its peak at the end of the work.

La contrainte, initialement élevée, devient constante après la création du filetage pour atteindre son pic à la fin des travaux.

El esfuerzo, inicialmente elevado, se vuelve constante después de crear la rosca, para luego alcanzar el pico al final del trabajo.

## VITI TRI-LOBATE

Tri-lobe screws  
Vis trilobées  
Tornillos de tres lóbulos

**RECOMMENDED**

p. 76

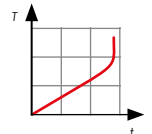

Data la particolare sezione della vite lo sforzo è molto elevato durante tutte le fasi dell'avvitatura.

Given the particular section of the screw, the stress is very high throughout the entire screwing operation.

Étant donnée la section particulière de la vis, la contrainte est très élevée pendant toutes les phases de vissage.

Teniendo en cuenta la particular sección del tornillo, el esfuerzo es muy grande durante todas las fases de atornillado.

## VITI VERNICIATE O DANNEGGIATE

Painted or damaged screws  
Vis peintes ou endommagées  
Tornillos barnizados o dañados

**RECOMMENDED**

p. 88 p. 124

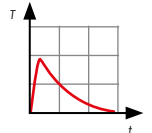

In presenza di teste di viti arrugginite o verniciate il grip dell'inserto tende a diminuire rendendo particolarmente difficoltose le operazioni.

In the presence of rusty or painted screw heads, the grip of the insert bit tends to decrease, making it particularly difficult to perform the operations.

En présence de têtes de vis rouillées ou peintes, l'adhérence de l'embout a tendance à diminuer en rendant les opérations particulièrement difficiles.

Si hay cabezas de tornillo oxidadas o barnizadas, el agarre de la punta tenderá a disminuir dificultando el trabajo.



Gli inserti con attacco da 1/4" rappresentano senza dubbio la parte più significativa del mercato degli utensili per avvitatori. Ogni produttore deve quindi essere in grado di offrire ai propri clienti una gamma sufficientemente ampia di forme e di lunghezze, così da poter "risolvere il problema" in ogni occasione. Le linee di prodotti standard (ESSENTIAL) che presentiamo in questa sezione rispondono esattamente a queste necessità. Anche il confezionamento ed i metodi di presentazione sul punto vendita costituiscono un'aspetto del prodotto. Per questo motivo abbiamo sviluppato nuove e diversificate soluzioni espositive, che vanno dal bit-set più semplice all'espositore più completo.

Insert with 1/4" attachment account for the largest slice of the market of tools for drivers. As a manufacturer, we are able to offer our customers a wide range of shapes and lengths, so that they can be the ideal choice for any application. The standard or ESSENTIAL product lines presented in this section perfectly meet these requirements. The packaging and presentation of the products in the store is also an important aspect and we have worked hard to develop a complete range of counter displays, which include innovative pocket-sized bit sets with a brand new design.

Les embouts avec queue 1/4" représentent la partie la plus importante du marché des outils pour visseuses. En tant que producteur, nous sommes donc en mesure d'offrir à nos clients un large éventail de formes et de longueurs, afin de proposer un choix idéal pour toute application. Les lignes de produits standard ou ESSENTIAL, que nous présentons dans cette section correspondent exactement à ce type de caractéristiques. Même l'emballage et la présentation du produit dans le point de vente constituent un aspect important auquel nous avons consacré beaucoup d'énergie, en développant des solutions d'exposition sur comptoir complètes, ainsi que des jeux d'embouts de poche, au nouveau design.

Las puntas con empalmes de 1/4" representan la parte más significativa del mercado de los utensilios para atornilladores. Como productores podemos ofrecer a nuestros clientes una gama tan amplia de formas y longitudes hasta el punto de convertirnos en la elección ideal para cualquier aplicación. Las líneas de los productos estándar o ESSENTIAL que presentamos en esta sección confirman exactamente esta característica. También la presentación y el embalaje en el punto venta del producto constituyen un aspecto importante al cual hemos dedicado mucha energía, desarrollando soluciones de exposición para mostradores completas, así como innovadores juegos de puntas de bolsillo con el nuevo diseño.



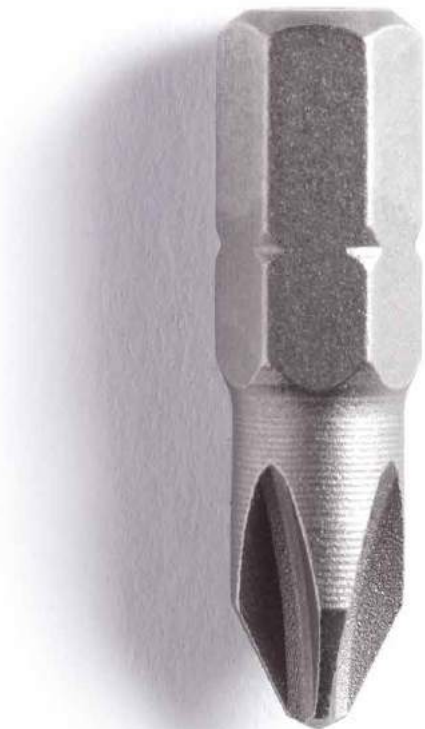













# 1.2

1.2



## LINEE ESSENTIAL ESSENTIAL LINES LIGNES ESSENTIAL LÍNEAS ESSENTIAL

		<b>1/4" PHILLIPS®</b>	p. 132
		<b>1/4" POZIDRIV®</b>	p. 138
		<b>1/4" PER VITI TORX®</b> FOR TORX® SCREWS • POUR VIS TORX® • PARA TORNILLOS TORX®	p. 142
		<b>1/4" PER VITI TORX® CON FORO</b> FOR TORX® SCREWS WITH HOLE • POUR VIS TORX® AVEC TROU • PARA TORNILLOS TORX® CON ORIFICIO	p. 144
		<b>1/4" CONICO PER VITI TORX®</b> TAPERED FOR TORX® SCREWS • CONIQUE POUR VIS TORX® • CÓNICO PARA TORNILLOS TORX®	p. 146
		<b>1/4" CONICO PER VITI TORX®</b> TAPERED FOR TORX® SCREWS • CONIQUE POUR VIS TORX® • CÓNICO PARA TORNILLOS TORX®	p. 147
		<b>1/4" PER VITI TORX-PLUS®</b> FOR TORX-PLUS® SCREWS • POUR VIS TORX-PLUS® • PARA TORNILLOS TORX-PLUS®	p. 148
		<b>1/4" PER VITI 5 LOBI</b> FOR 5-LOBE SCREWS • POUR VIS 5 LOBES • PARA TORNILLOS DE 5 LÓBULOS	p. 149
		<b>1/4" ESAGONO</b> HEXAGON • TÊTE HEXAGONALE • HEXÁGONO	p. 150
		<b>1/4" ESAGONO SFERICO</b> SPHERICAL HEXAGON • TÊTE HEXAGONALE SPHÉRIQUE • HEXÁGONO ESFÉRICO	p. 152
		<b>1/4" ESAGONO FORATO</b> HEXAGON WITH HOLE • TÊTE HEXAGONALE PERCÉE • HEXÁGONO CON ORIFICIO	p. 153
		<b>1/4" ESAGONO (POLLICI)</b> HEXAGON (INCHES) • TÊTE HEXAGONALE (POUCES) • HEXÁGONO (PULGADAS)	p. 153

		<b>1/4" TAGLIO</b> SLOTTED • FENTE • CORTE	p. 154
		<b>1/4" PLUS/MINUS TAGLIO/PH</b> PLUS/MINUS SLOT/PH • PLUS/MINUS FENTE/PH • PLUS/MINUS CORTE/PH	p. 158
		<b>1/4" PLUS/MINUS TAGLIO/PZ</b> PLUS/MINUS SLOT/PZ • PLUS/MINUS FENTE/PZ • PLUS/MINUS CORTE/PZ	p. 159
		<b>1/4" QUADRO</b> SQUARE • CARRÉ • CUADRADO	p. 160
		<b>1/4" SPANNER</b>	p. 161
		<b>1/4" TRI-WING®</b>	p. 162
		<b>1/4" TORQ-SET®</b>	p. 163
		<b>1/4" XZN</b>	p. 164
		<b>ASSI-SIT</b>	p. 165
		<b>1/4" PH DOPPIO</b> DOUBLE PH • PH DOUBLE • PH DOBLE	p. 166
		<b>1/4" PZ DOPPIO</b> DOUBLE PZ • PZ DOUBLE • PZ DOBLE	p. 166
		<b>1/4" DOPPI TAGLIO-PH</b> DOUBLE SLOT-PH • DOUBLE FENTE-PH • DOBLE CORTE-PH	p. 167
		<b>1/4" DOPPI TAGLIO-PZ</b> DOUBLE SLOT-PZ • DOUBLE FENTE-PZ • DOBLE CORTE-PZ	p. 167
		<b>1/4" CHIAVI A BUSSOLA</b> NUT SETTERS • DOUILLES • LLAVE DE VASO	p. 188

# ESSENTIAL

## LINEE ESSENTIAL

Essential lines

Lignes essential

Líneas essential

Lavorazioni meccaniche eseguite con moderne macchine a CN di elevata affidabilità per conferire alle geometrie dell'inserto la precisione necessaria al miglior accoppiamento con la vite.

*Mechanical processes performed with modern CNC machines to give the geometries of the bit the precision necessary for better screw coupling.*

*Usinages mécaniques effectués avec des machines modernes à CN pour conférer aux formes de l'embout la précision nécessaire au meilleur accouplement avec la vis.*

*Trabajos mecánicos realizados con modernas máquinas con CN (Control Numérico) para dar a las geometrías de la punta la precisión necesaria para acoplarse mejor con el tornillo.*

Acciaio di altà qualità al Cromo-Molibdeno-Vanadio temprato a cuore. Temperatura di rinvenimento calibrata per dare ad ogni tipologia la durezza ottimale.

*High-quality chrome-molybdenum-vanadium hardened steel and recovery temperature calibrated to strengthen each insert bit to its maximum hardness.*

*Acier haute qualité au chrome-molybdène-vanadium trempé à cœur et température de revenu calibrée pour donner à chaque type d'embout une dureté optimale.*

*Acero de alta calidad de Cromo-Molibdeno-Vanadio templado incluyendo su núcleo y con temperatura de revenimiento calibrada para dar a cada tipología de punta la mejor dureza.*



La fosfatazione allo zinco come rivestimento superficiale conferisce a questa linea di prodotto un'ottima resistenza all'ossidazione.

*Zinc phosphate as a surface coating offers this product line excellent oxidation resistance.*

*La fosfatación al zinc del revestimiento superficial proporciona a esta línea de productos una óptima resistencia a la oxidación.*

*El fosfatado de zinc como recubrimiento superficial proporciona a esta línea de productos una óptima resistencia a la oxidación.*



Controlli qualitativi e attenzione al customer satisfaction permettono di mantenere la qualità dei nostri prodotti sempre ai massimi livelli.

*Strict quality controls and constant attention to customer satisfaction ensure that the quality of our products is always at the highest levels.*

*Des contrôles qualité extrêmement précis et une attention constante à la satisfaction du client permettent de maintenir la qualité de nos produits toujours au plus haut niveau.*

*Los estrictos controles de la calidad y una atención constante para satisfacer las necesidades del cliente permiten mantener la calidad de nuestros productos siempre al máximo.*



Grazie all'ottimo equilibrio tra durezza e tenacità, i nostri inserti ESSENTIAL non presentano rischi di rotture precoci e pericolose.

*The perfect balance between hardness and toughness of our ESSENTIAL bits, prevent premature and dangerous breakage.*

*Grâce à l'excellent équilibre entre la dureté et la ténacité, nos embouts ESSENTIAL ne présentent pas de risque de ruptures prématurées et dangereuses.*

*Gracias al óptimo equilibrio entre dureza y tenacidad, nuestras puntas ESSENTIAL no corren el riesgo de sufrir rupturas precoces y peligrosas.*

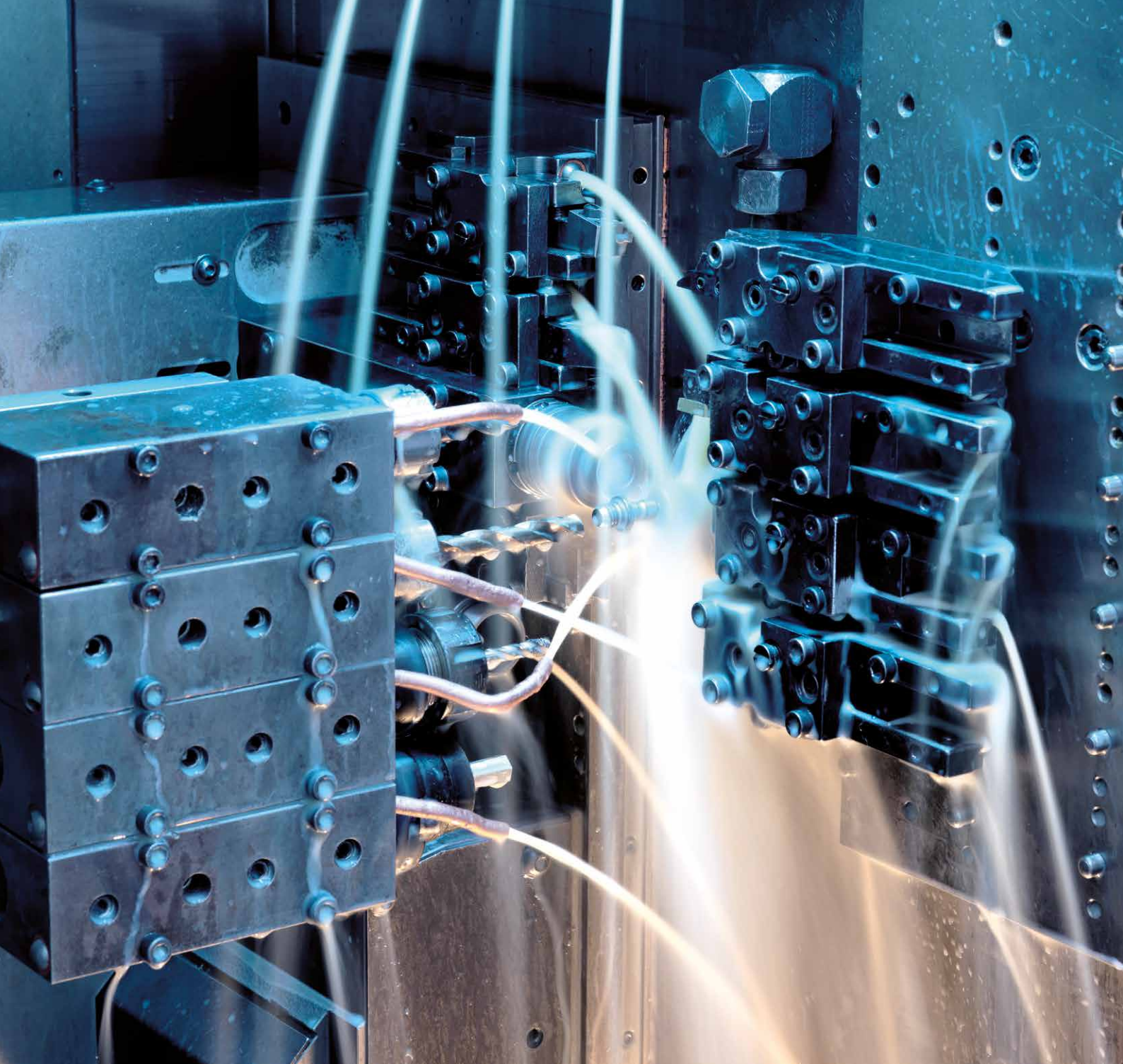

*Particolare di una nostra macchina utensile: tornio CN a 10 assi ad alta precisione.*

*One of our machine tools: CN lathe with 10 high-precision axes.*

*Détail de notre machine outil : tour CN à 10 axes à haute précision.*

*Detalle de una máquina utensilio nuestra: torno CN de 10 ejes de alta precisión.*



# 1.2 LINEE ESSENTIAL

ESSENTIAL LINES  
LIGNES ESSENTIAL  
LÍNEAS ESSENTIAL

## 61043

### PH FRESATI

INSERTI 1/4" C PHILLIPS® IMPRONTA FRESATA  
1/4" C PHILLIPS® BITS MILLED TIP  
EMBOUTS 1/4" C PHILLIPS® EMPREINTE FRAISÉE  
PUNTAS DE 1/4" C PHILLIPS® HUELLA FRESADA

58/60 HRC

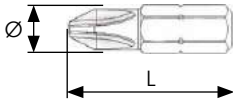

**EASYPACK** | sacchetto PVC con Euro-hole • PVC bags with Euro-hole

	L mm	Ø mm	PCS.	COD.	€ cad./each
<b>PH0</b>	25	3	10	61043005	0,590
<b>PH1</b>	25	4,5	10	61043010	0,590
<b>PH2</b>	25	6	10	61043020	0,590
<b>PH3</b>	25	6	10	61043030	0,590
<b>PH4</b>	32	10	10	61043040	2,280



**SELPACK**  
2 pcs.

	L mm	COD.	€ box
<b>PH0</b>	25	61043005002	2,520
<b>PH1</b>	25	61043010002	2,520
<b>PH2</b>	25	61043020002	2,520
<b>PH3</b>	25	61043030002	2,520
<b>PH4</b>	32	61043040002	5,900



**MINIBOX**  
10 pcs.

	L mm	COD.	€ box
<b>PH0</b>	25	61043005010	6,700
<b>PH1</b>	25	61043010010	6,700
<b>PH2</b>	25	61043020010	6,700
<b>PH3</b>	25	61043030010	6,700
<b>PH4</b>	32	61043040010	24,200

## 61046

### PH FRESATI

INSERTI 1/4" C PHILLIPS® IMPRONTA FRESATA TIPO LUNGO  
1/4" C PHILLIPS® BITS LONG MILLED TIP  
EMBOUTS 1/4" C PHILLIPS® EMPREINTE FRAISÉE LONGUE  
PUNTAS DE 1/4" C PHILLIPS® HUELLA FRESADA TIPO LARGO

58/60 HRC

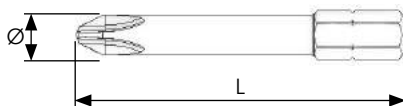

**EASYPACK** | sacchetto PVC con Euro-hole • PVC bags with Euro-hole

	L mm	Ø mm	PCS.	COD.	€ cad./each
<b>PH1</b>	50	4,5	5	61046005	1,690
<b>PH2</b>	50	6	5	61046010	1,690
<b>PH3</b>	50	8	5	61046015	2,870



# 61051 PH FRESATI

LAME 1/4"E PHILLIPS® IMPRONTA FRESATA  
1/4"E PHILLIPS® POWER BITS MILLED TIP  
EMBOUTS 1/4"E PHILLIPS® EMPREINTE FRAISÉE  
PUNTAS DE 1/4"E PHILLIPS® HUELLA FRESADA

58/60 HRC

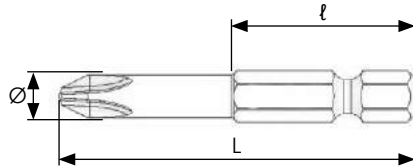

EASYPACK | sacchetto PVC con Euro-hole • PVC bags with Euro-hole

+	L mm	l mm	Ø mm	PCS.	COD.	€ cad./each
PH0	50	25	3	5	61051005	2,750
	75	25	3	5	61051010	4,740
	100	25	3	5	61051015	11,000
PH1	50	25	4,5	5	61051020	1,640
	70	25	4,5	5	61051024	2,250
	75	25	4,5	5	61051030	2,280
	90	25	4,5	5	61051034	2,870
	100	25	4,5	5	61051035	3,030
	127	25	4,5	5	61051037	4,290
	150	25	4,5	5	61051040	4,930
PH2	200	25	4,5	5	61051178	11,300
	50	25	6	5	61051045	1,640
	70	25	6	5	61051055	2,250
	75	25	6	5	61051060	2,280
	90	25	6	5	61051065	2,870
	100	25	6	5	61051070	3,030
	120	25	6	5	61051075	4,180
PH3	127	25	6	5	61051077	4,290
	150	25	6	5	61051080	4,930
	200	25	6	5	61051315	11,300
	50	25	6	5	61051085	1,640
	50	25	8	5	61051088	3,300
	75	25	6	5	61051090	3,190
	75	25	8	5	61051093	7,230
PH4	100	25	6	5	61051095	4,100
	100	25	8	5	61051098	9,110
	150	25	8	5	61051100	16,700
PH4	50	25	10	5	61051105	4,820

+	L mm	COD.	€ box
PH1	50	61051020002	4,610
	75	61051030002	5,900
	100	61051035002	7,400
PH2	50	61051045002	4,610
	75	61051060002	5,900
	100	61051070002	7,400
PH3	50	61051085002	4,610
PH4	50	61051105002	11,000



SELPACK  
2 pcs.



MINIBOX  
5 pcs.

+	L mm	COD.	€ box
PH1	50	61051020005	8,570
	75	61051030005	12,000
	100	61051035005	15,900
PH2	50	61051045005	8,570
	75	61051060005	12,000
	100	61051070005	15,900
PH3	50	61051085005	8,570
PH4	50	61051105005	25,400

1.2





# 1.2 LINEE ESSENTIAL

ESSENTIAL LINES  
LIGNES ESSENTIAL  
LÍNEAS ESSENTIAL

## 61051 PH FRESATI CORPO RIDOTTO

LAME 1/4" E PHILLIPS® CORPO RIDOTTO IMPRONTA FRESATA  
REDUCED BODY 1/4" E PHILLIPS® POWER BITS MILLED TIP  
EMBOUTS RÉDUITE 1/4" E PHILLIPS® EMPREINTE FRAISÉE  
PUNTAS DE 1/4" E PHILLIPS® REDUCIDA HUELLA FRESADA

58/60 HRC

**EASYPACK** | sacchetto PVC con Euro-hole • PVC bags with Euro-hole

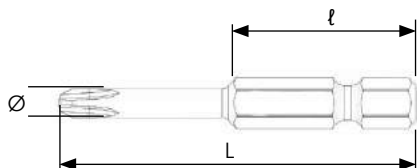

	L mm	ℓ mm	Ø mm	PCS.	COD.	€ cad./each
PH1	50	25	3	5	61051110	6,160
	75	25	3	5	61051125	8,200
	100	25	3	5	61051140	12,800
PH2	50	25	4	5	61051200	6,150
	50	25	5	5	61051205	6,150
	75	25	3	5	61051215	8,200
	75	25	4	5	61051225	8,200
	75	25	5	5	61051230	8,200
	100	25	4	5	61051240	12,400
	100	25	5	5	61051250	12,300



### FOCUS ON



La fresatura, o più correttamente profilatura, è la lavorazione per asportazione di truciolo che viene eseguita per realizzare l'impronta dell'inserto. Noi la eseguiamo con apposite macchine costruite in Germania ed utensili per fresatura specifici per ogni misura di impronta. La profilatura, unitamente all'operazione di tornitura, riescono a garantire alle geometrie dell'inserto una precisione superiore rispetto al metodo di stampatura a freddo.

Milling, or more correctly, profiling, is the chip removal process which is performed to create the tip of the insert bit. We perform this with special milling machines and tools specific to each tip size. Profiling, together with the turning operation, gives the bit greater geometric precision than cold pressing.

Le fraisage, ou plus correctement le profilage, est l'usinage par enlèvement de copeaux qui est effectué pour réaliser l'empreinte de l'embout. Nous l'effectuons avec des machines spéciales et des outils de fraisage spécifiques à chaque mesure d'empreinte. Le profilage et l'opération de tournage sont en mesure de garantir aux formes de l'embout une précision supérieure par rapport à la méthode de pressage à froid.

El fresado, o con más precisión, el perfilado, es el trabajo de eliminación de la viruta que se realiza para formar la huella de la punta. Nosotros la realizamos con máquinas y utensilios idóneos para el fresado específicos para cada medida de huella. El perfilado, junto a la operación de torneado, consiguen garantizar a las geometrías de la punta una precisión superior con respecto al método de moldeado en frío.

# LAB TEST





## 61044 PH EXTRA-HARD

INSERTI 1/4"C EXTRA HARD PHILLIPS® IMPRONTA FRESATA  
EXTRA-HARD 1/4"C PHILLIPS® BITS MILLED TIP  
EMBOUS 1/4"C EXTRA HARD PHILLIPS® EMPREINTE FRAISÉE  
PUNTAS DE 1/4"C EXTRA DURAS PHILLIPS® HUELLA FRESADA

60/62 HRC

**EASYPACK** | sacchetto PVC con Euro-hole • PVC bags with Euro-hole



+	L mm	Ø mm	PCS.	COD.	€ cad./each
PH1	25	4,5	10	61044005	0,780
PH2	25	4,5	10	61044010	0,780
PH2	25	1/4	10	61044020*	0,780

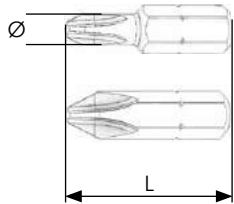

\*61044020

1.2



### FOCUS ON



Questi inserti sono specifici per utilizzi dove non siano applicate elevate coppie di serraggio: su legni teneri o lamiera. L'elevata durezza preserva l'integrità dell'impronta e aumenta l'efficienza dell'utensile.

These bits are specifically for applications that do not require the use of high torques: on soft wood or sheet metal. The extra hardness preserves the integrity of the tip and increases tool efficiency.

Ces embouts sont spécifiques pour les utilisations où sont appliqués des couples élevés de serrage : sur des bois tendres ou des tôles. La dureté élevée préserve l'intégrité de l'empreinte et augmente l'efficacité de l'outil.

Estas puntas son específicos para usos donde no se apliquen elevados pares de torsión de cierre: sobre madera tierna o chapa. La elevada dureza preserva la integridad de la huella y aumenta la eficiencia del utensilio.

## 61047 PH ESAGONALI

INSERTI 1/4"C CORPO ESAGONALE PHILLIPS® IMPRONTA FRESATA  
HEXAGON BODY 1/4"C PHILLIPS® BITS MILLED TIP  
EMBOUS 1/4"C FRAISÉE HEXAGONALE PHILLIPS® EMPREINTE FRAISÉE  
PUNTAS DE 1/4"C CUERPO HEXAGONAL PHILLIPS® HUELLA FRESADA

58/60 HRC

**EASYPACK** | sacchetto PVC con Euro-hole • PVC bags with Euro-hole



+	L mm	PCS.	COD.	€ cad./each
PH1	25	10	61047005	0,700
PH2	25	10	61047015	0,700
PH3	25	10	61047025	0,700

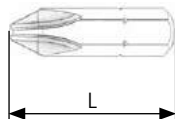



# 1.2 LINEE ESSENTIAL

ESSENTIAL LINES  
LIGNES ESSENTIAL  
LÍNEAS ESSENTIAL

## 61048 PH STAMPATI

INSERTI 1/4"C PHILLIPS® IMPRONTA STAMPATA  
1/4"C PHILLIPS® BITS FORGED TIP  
EMBOUS 1/4"C PHILLIPS® EMPREINTE FORGÉE  
PUNTAS DE 1/4"C PHILLIPS® HUELLA IMPRESA

58/60 HRC

EASYPACK | sacchetto PVC con Euro-hole • PVC bags with Euro-hole

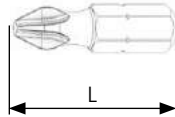

	L mm	PCS.	COD.	€ cad./each
PH1	25	10	61048005	0,570
PH2	25	10	61048015	0,570
PH3	25	10	61048025	0,570



SELPACK  
2 pcs.

	L mm	COD.	€ box
PH1	25	61048005002	2,470
PH2	25	61048015002	2,470
PH3	25	61048025002	2,470



MINIBOX  
10 pcs.

	L mm	COD.	€ box
PH1	25	61048005010	6,300
PH2	25	61048015010	6,300
PH3	25	61048025010	6,300

## 61056 PH STAMPATI

LAME 1/4"E PHILLIPS® IMPRONTA STAMPATA  
1/4"E PHILLIPS® POWER BITS FORGED TIP  
EMBOUS 1/4"E PHILLIPS® EMPREINTE FORGÉE  
PUNTAS DE 1/4"E PHILLIPS® HUELLA IMPRESA

58/60 HRC

EASYPACK | sacchetto PVC con Euro-hole • PVC bags with Euro-hole

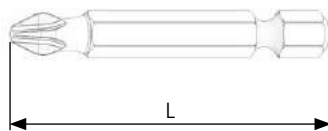

	L mm	PCS.	COD.	€ cad./each
PH1	50	5	61056030	1,560
PH2	50	5	61056035	1,560
PH3	50	5	61056040	1,560



SELPACK  
2 pcs.

	L mm	COD.	€ box
PH1	50	61056030002	4,450
PH2	50	61056035002	4,450
PH3	50	61056040002	4,450



MINIBOX  
5 pcs.

	L mm	COD.	€ box
PH1	50	61056030005	8,170
PH2	50	61056035005	8,170
PH3	50	61056040005	8,170





# 61057 PH CARTONGESSO

INSERTI 1/4" PHILLIPS® CON BUSSOLA DI FERMO PER CARTONGESSO  
 1/4" PHILLIPS® BITS WITH STOP FOR DRYWALL  
 EMBOUTS 1/4" "PHILLIPS® AVEC DOUILLE DE BUTÉE POUR PLAQUES DE PLÂTRE  
 PUNTAS DE 1/4" PHILLIPS® CON LLAVE TUBULAR DE TOPE PARA PLADUR

58/60 HRC

**EASYPACK** | sacchetto PVC con Euro-hole • PVC bags with Euro-hole



	L mm	PCS.	COD.	€ cad./each
<b>PH2</b>	25	10	61057010	<b>1,480</b>

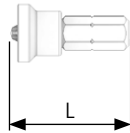

	L mm	PCS.	COD.	€ cad./each
<b>PH2</b>	50	5	61057020	<b>2,250</b>

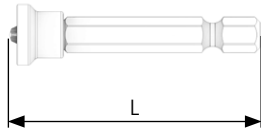

## FOCUS ON

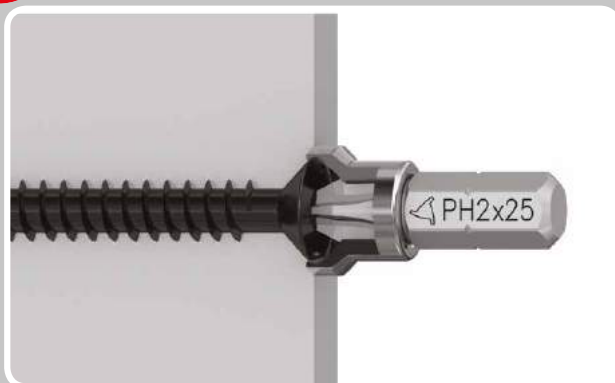

La bussola copre la testa della vite: in questo modo si evita di penetrare eccessivamente nel cartongesso facilitando così le operazioni di stuccatura.

The socket covers the head of the screw: this prevents excessive penetration into plasterboard, thus facilitating the grouting operations.

La douille couvre la tête de la vis : cela évite de trop pénétrer dans la plaque de plâtre en facilitant ainsi les opérations de jointoiement.

El vaso cubre la cabeza del tornillo: de esta manera se evita tener que penetrar excesivamente en el pladur facilitando la operación de estucado.

# LAB TEST





# 1.2 LINEE ESSENTIAL

ESSENTIAL LINES  
LIGNES ESSENTIAL  
LÍNEAS ESSENTIAL

## 61069 PZ FRESATI

INSERTI 1/4" C POZIDRIV® IMPRONTA FRESATA  
1/4" C POZIDRIV® BITS MILLED TIP  
EMBOUITS 1/4" C POZIDRIV® EMPREINTE FRAISÉE  
PUNTAS DE 1/4" C POZIDRIV® HUELLA FRESADA

58/60 HRC

**EASYPACK** | sacchetto PVC con Euro-hole • PVC bags with Euro-hole

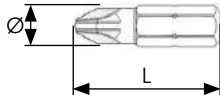

	L mm	Ø mm	PCS.	COD.	€ cad./each
<b>PZ0</b>	25	3	10	61069005	0,590
<b>PZ1</b>	25	4,5	10	61069010	0,590
<b>PZ2</b>	25	6	10	61069020	0,590
<b>PZ3</b>	25	6	10	61069030	0,590
<b>PZ4</b>	32	10	10	61069040	2,280



**SELPACK**  
2 pcs.

	L mm	COD.	€ box
<b>PZ0</b>	25	61069005002	2,520
<b>PZ1</b>	25	61069010002	2,520
<b>PZ2</b>	25	61069020002	2,520
<b>PZ3</b>	25	61069030002	2,520
<b>PZ4</b>	32	61069040002	5,900



**MINIBOX**  
10 pcs.

	L mm	COD.	€ box
<b>PZ0</b>	25	61069005010	6,700
<b>PZ1</b>	25	61069010010	6,700
<b>PZ2</b>	25	61069020010	6,700
<b>PZ3</b>	25	61069030010	6,700
<b>PZ4</b>	32	61069040010	24,200

## 61075 PZ FRESATI

INSERTI 1/4" C POZIDRIV® IMPRONTA FRESATA TIPO LUNGO  
1/4" C POZIDRIV® BITS LONG MILLED TIP  
EMBOUITS 1/4" C POZIDRIV® EMPREINTE FRAISÉE LONGUE  
PUNTAS DE 1/4" C POZIDRIV® HUELLA FRESADA TIPO LARGO

58/60 HRC

**EASYPACK** | sacchetto PVC con Euro-hole • PVC bags with Euro-hole

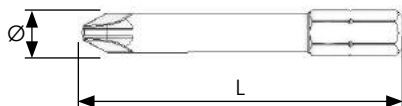

	L mm	Ø mm	PCS.	COD.	€ cad./each
<b>PZ1</b>	50	4,5	5	61075005	1,690
<b>PZ2</b>	50	6	5	61075010	1,690
<b>PZ3</b>	50	8	5	61075015	2,870



# 61076 PZ FRESATI

LAME 1/4"E POZIDRIV® IMPRONTA FRESATA  
1/4"E POZIDRIV® POWER BITS MILLED TIP  
EMBOUTS 1/4"E POZIDRIV® EMPREINTE FRAISÉE  
PUNTAS DE 1/4"E POZIDRIV® HUELLA FRESADA

58/60 HRC

EASYPACK | sacchetto PVC con Euro-hole • PVC bags with Euro-hole

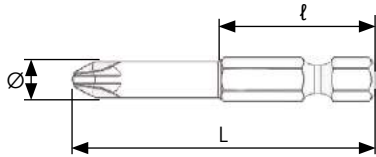

+	L mm	l mm	Ø mm	PCS.	COD.	€ cad./each
<b>PZ0</b>	50	25	3	5	61076005	2,750
	50	25	4,5	5	61076010	1,640
	70	25	4,5	5	61076019	2,250
	75	25	4,5	5	61076020	2,280
	90	25	4,5	5	61076024	2,870
<b>PZ1</b>	100	25	4,5	5	61076025	3,030
	127	25	4,5	5	61076085	4,290
	150	25	4,5	5	61076030	4,930
	200	25	4,5	5	61076033	11,300
	50	25	6	5	61076035	1,640
<b>PZ2</b>	70	25	6	5	61076044	2,250
	75	25	6	5	61076045	2,280
	90	25	6	5	61076049	2,870
	100	25	6	5	61076050	3,030
	127	25	6	5	61076054	4,290
<b>PZ3</b>	150	25	6	5	61076055	4,930
	200	25	6	5	61076057	11,300
	50	25	6	5	61076060	1,640
	50	25	8	5	61076063	3,300
	75	25	6	5	61076065	3,190
<b>PZ4</b>	100	25	6	5	61076070	4,100
	100	25	8	5	61076073	9,110
	150	25	7	5	61076120	16,700
<b>PZ4</b>	50	25	10	5	61076075	4,820

1.2



+	L mm	COD.	€ box
<b>PZ1</b>	50	61076010002	4,610
	75	61076020002	5,900
	100	61076025002	7,400
<b>PZ2</b>	50	61076035002	4,610
	75	61076045002	5,900
	100	61076050002	7,400
<b>PZ3</b>	50	61076060002	4,610
<b>PZ4</b>	50	61076075002	11,000



SELPACK  
2 pcs.



MINIBOX  
5 pcs.

+	L mm	COD.	€ box
<b>PZ1</b>	50	61076010005	8,570
	75	61076020005	12,000
	100	61076025005	15,900
<b>PZ2</b>	50	61076035005	8,570
	75	61076045005	12,000
	100	61076050005	15,900
<b>PZ3</b>	50	61076060005	8,570
	100	61076070005	25,400





# 1.2 LINEE ESSENTIAL

ESSENTIAL LINES  
LIGNES ESSENTIAL  
LÍNEAS ESSENTIAL

**61070**

**PZ EXTRA-HARD**

INSERTI 1/4"C POZIDRIV® IMPRONTA FRESATA EXTRA HARD  
1/4"C POZIDRIV® BITS EXTRA HARD MILLED TIP  
EMBOUITS 1/4"C POZIDRIV® EMPREINTE FRAISÉE EXTRA HARD  
PUNTAS DE 1/4"C POZIDRIV® HUELLA FRESADA EXTRA DUROS

60/62 HRC

**EASYPACK** | sacchetto PVC con Euro-hole • PVC bags with Euro-hole



+	L mm	Ø mm	PCS.	COD.	€ cad./each
<b>PZ1</b>	25	4,5	10	61070005	0,780
<b>PZ2</b>	25	4,5	10	61070008	0,780
<b>PZ2</b>	25	1/4	10	61070010*	0,780

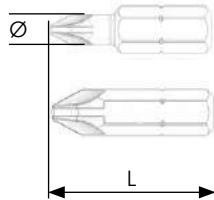

\*61070010

**61072**

**PZ ESAGONALI**

INSERTI 1/4"C POZIDRIV® IMPRONTA FRESATA CORPO ESAGONALE  
1/4"C POZIDRIV® BITS MILLED TIP HEXAGON BODY  
EMBOUITS 1/4"C POZIDRIV® EMPREINTE FRAISÉE HEXAGONALE  
PUNTAS DE 1/4"C POZIDRIV® HUELLA FRESADA CUERPO HEXAGONAL

58/60 HRC

**EASYPACK** | sacchetto PVC con Euro-hole • PVC bags with Euro-hole



+	L mm	PCS.	COD.	€ cad./each
<b>PZ1</b>	25	10	61072005	0,700
<b>PZ2</b>	25	10	61072010	0,700
<b>PZ3</b>	25	10	61072015	0,700

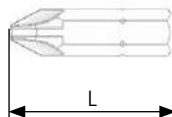

## TIPS

Il corpo pieno interamente esagonale permette di applicare la massima torsione.

The full hexagonal body allows applying the maximum torque.

Le corps plein hexagonal permet d'appliquer une torsion maximale.

El cuerpo entero internamente hexagonal permite aplicar la máxima torsión.



# 61073 PZ STAMPATI

INSERTI 1/4" C POZIDRIV® IMPRONTA STAMPATA  
1/4" C POZIDRIV® BITS FORGED TIP  
EMBOUTS 1/4" C POZIDRIV® EMPREINTE FORGÉE  
PUNTAS DE 1/4" C POZIDRIV® HUELLA IMPRESA

58/60 HRC

EASYPACK | sacchetto PVC con Euro-hole • PVC bags with Euro-hole

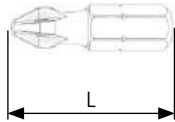

	L mm	PCS.	COD.	€ cad./each
<b>PZ1</b>	25	10	61073005	0,570
<b>PZ2</b>	25	10	61073015	0,570
<b>PZ3</b>	25	10	61073025	0,570



SELFPACK  
2 pcs.

	L mm	COD.	€ box
<b>PZ1</b>	25	61073005002	2,470
<b>PZ2</b>	25	61073015002	2,470
<b>PZ3</b>	25	61073025002	2,470



MINIBOX  
10 pcs.

	L mm	COD.	€ box
<b>PZ1</b>	25	61073005010	6,300
<b>PZ2</b>	25	61073015010	6,300
<b>PZ3</b>	25	61073025010	6,300

# 61082 PZ STAMPATI

LAME 1/4" E POZIDRIV® IMPRONTA STAMPATA  
1/4" E POZIDRIV® POWER BITS FORGED TIP  
EMBOUTS 1/4" E POZIDRIV® EMPREINTE FORGÉE  
PUNTAS DE 1/4" E POZIDRIV® HUELLA IMPRESA

58/60 HRC

EASYPACK | sacchetto PVC con Euro-hole • PVC bags with Euro-hole

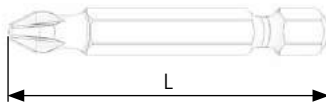

	L mm	PCS.	COD.	€ cad./each
<b>PZ1</b>	50	5	61082030	1,560
<b>PZ2</b>	50	5	61082035	1,560
<b>PZ3</b>	50	5	61082040	1,560



SELFPACK  
2 pcs.

	L mm	COD.	€ box
<b>PZ1</b>	50	61082030002	4,450
<b>PZ2</b>	50	61082035002	4,450
<b>PZ3</b>	50	61082040002	4,450



MINIBOX  
5 pcs.

	L mm	COD.	€ box
<b>PZ1</b>	50	61082030005	8,170
<b>PZ2</b>	50	61082035005	8,170
<b>PZ3</b>	50	61082040005	8,170



# 1.2 LINEE ESSENTIAL

ESSENTIAL LINES  
LIGNES ESSENTIAL  
LÍNEAS ESSENTIAL

**61094** TX

INSERTI 1/4" C PER VITI TORX®  
1/4" C BITS FOR TORX® SCREWS  
EMBOUTS 1/4" C POUR VIS TORX®  
PUNTAS DE 1/4" C PARA TORNILLOS TORX®

58/60 HRC

**EASYPACK** | sacchetto PVC con Euro-hole • PVC bags with Euro-hole

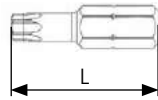

	L mm	PCS.	COD.	€ cad./each
<b>TX06</b>	25	10	61094005	1,020
<b>TX07</b>	25	10	61094010	1,020
<b>TX08</b>	25	10	61094015	1,020
<b>TX09</b>	25	10	61094020	1,020
<b>TX10</b>	25	10	61094025	1,020
<b>TX15</b>	25	10	61094030	1,020
<b>TX20</b>	25	10	61094035	1,020
<b>TX25</b>	25	10	61094040	1,020
<b>TX27</b>	25	10	61094045	1,020
<b>TX30</b>	25	10	61094050	1,020
<b>TX40</b>	25	10	61094055	1,020
<b>TX45</b>	25	10	61094060	2,410
<b>TX50</b>	25	10	61094065	2,410

	L mm	COD.	€ box
<b>TX06</b>	25	61094005002	3,380
<b>TX07</b>	25	61094010002	3,380
<b>TX08</b>	25	61094015002	3,380
<b>TX09</b>	25	61094020002	3,380
<b>TX10</b>	25	61094025002	3,380
<b>TX15</b>	25	61094030002	3,380
<b>TX20</b>	25	61094035002	3,380
<b>TX25</b>	25	61094040002	3,380
<b>TX27</b>	25	61094045002	3,380
<b>TX30</b>	25	61094050002	3,380
<b>TX40</b>	25	61094055002	3,380



**SELPACK**  
2 pcs.

	L mm	COD.	€ box
<b>TX06</b>	25	61094005010	11,700
<b>TX07</b>	25	61094010010	11,700
<b>TX08</b>	25	61094015010	11,700
<b>TX09</b>	25	61094020010	11,700
<b>TX10</b>	25	61094025010	11,700
<b>TX15</b>	25	61094030010	11,700
<b>TX20</b>	25	61094035010	11,700
<b>TX25</b>	25	61094040010	11,700
<b>TX27</b>	25	61094045010	11,700
<b>TX30</b>	25	61094050010	11,700
<b>TX40</b>	25	61094055010	11,700



**MINIBOX**  
10 pcs.



# 61097 TX

58/60 HRC

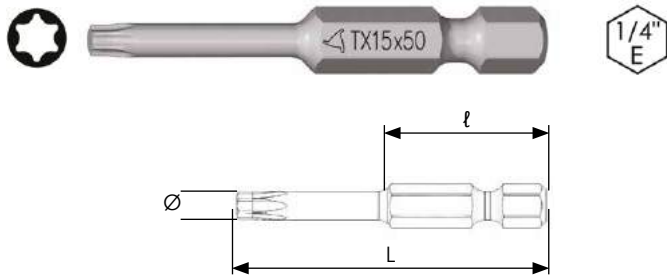

LAME 1/4"E PER VITI TORX®  
1/4"E POWER BITS FOR TORX® SCREWS  
EMBOUTS 1/4"E POUR VIS TORX®  
PUNTAS DE 1/4"E PARA TORNILLOS TORX®

**EASYPACK** | sacchetto PVC con Euro-hole • PVC bags with Euro-hole

1.2



	L mm	ℓ mm	Ø mm	PCS.	COD.	€ cad./each
<b>TX05</b>	50	25	3	5	61097005	5,090
	50	25	3	5	61097010	5,090
<b>TX06</b>	70	25	3	5	61097012	5,900
	100	25	3	5	61097014	9,110
	150	25	3	5	61097165	14,000
<b>TX07</b>	50	25	3	5	61097015	5,090
	70	25	3	5	61097017	5,900
<b>TX08</b>	50	25	3	5	61097020	5,090
	70	25	3	5	61097130	5,900
	100	25	3	5	61097133	9,110
<b>TX09</b>	150	25	3	5	61097170	14,000
	50	25	3	5	61097025	5,090
	50	25	4	5	61097030	3,080
<b>TX10</b>	70	25	4	5	61097035	4,560
	90	25	4	5	61097039	6,620
	100	25	4	5	61097040	6,700
	127	25	4	5	61097043	9,380
	150	25	4	5	61097160	11,200
<b>TX15</b>	200	25	5	5	61097205	17,200
	50	25	4	5	61097045	3,080
	70	25	4	5	61097050	4,560
	90	25	4	5	61097054	6,620
	100	25	4	5	61097055	6,700
	127	25	4	5	61097058	9,380
	150	25	4	5	61097135	11,200
	200	25	5	5	61097210	17,200

	L mm	ℓ mm	Ø mm	PCS.	COD.	€ cad./each
<b>TX20</b>	50	25	4,5	5	61097060	3,080
	70	25	5	5	61097065	4,560
	90	25	5	5	61097069	6,620
	100	25	5	5	61097070	6,700
	127	25	5	5	61097073	9,380
<b>TX25</b>	150	25	5	5	61097140	11,200
	200	25	5	5	61097215	17,200
	50	25	5	5	61097075	3,080
	70	25	5	5	61097080	4,560
	90	25	5	5	61097084	6,620
<b>TX27</b>	100	25	5	5	61097085	6,700
	127	25	5	5	61097088	9,380
	150	25	5	5	61097145	11,200
	200	25	5	5	61097220	17,200
	50	25	6	5	61097090	3,080
<b>TX30</b>	70	25	6	5	61097095	4,560
	90	25	6	5	61097099	6,620
	100	25	6	5	61097100	6,700
	127	25	6	5	61097102	9,380
	50	25	6	5	61097105	3,080
<b>TX40</b>	70	25	6	5	61097110	4,560
	90	25	6	5	61097114	6,620
	100	25	6	5	61097115	6,700
	127	25	6	5	61097118	9,380
	150	25	6	5	61097150	11,200
	50	25	1/4	5	61097120	3,080
	70	25	1/4	5	61097125	4,560
	90	25	1/4	5	61097127	6,620
	100	25	1/4	5	61097126	6,700
	150	25	1/4	5	61097128	11,200

	L mm	COD.	€ box
<b>TX10</b>	50	61097030002	7,500
<b>TX15</b>	50	61097045002	7,500
<b>TX20</b>	50	61097060002	7,500
<b>TX25</b>	50	61097075002	7,500
<b>TX27</b>	50	61097090002	7,500
<b>TX30</b>	50	61097105002	7,500
<b>TX40</b>	50	61097120002	7,500

	L mm	COD.	€ box
<b>TX10</b>	50	61097030005	16,400
<b>TX15</b>	50	61097045005	16,400
<b>TX20</b>	50	61097060005	16,400
<b>TX25</b>	50	61097075005	16,400
<b>TX27</b>	50	61097090005	16,400
<b>TX30</b>	50	61097105005	16,400
<b>TX40</b>	50	61097120005	16,400



**SELFPACK**  
2 pcs.



**MINIBOX**  
5 pcs.



# 1.2 LINEE ESSENTIAL

ESSENTIAL LINES  
LIGNES ESSENTIAL  
LÍNEAS ESSENTIAL

## 61111 TXH CON FORO

INSERTI 1/4" C PER VITI TORX® ANTI-MANOMISSIONE  
1/4" C BITS FOR TORX® SCREWS TAMPER-RESISTANT  
EMBOUTS 1/4" C POUR VIS TORX® AVEC SÉCURITÉ  
PUNTAS DE 1/4" C PARA TORNILLOS TORX® ANTIMANIPULACIONES

58/60 HRC

**EASYPACK** | sacchetto PVC con Euro-hole • PVC bags with Euro-hole

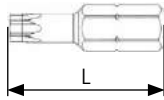

	L mm	PCS.	COD.	€ cad./each
<b>TXH09</b>	25	10	61111005	1,690
<b>TXH10</b>	25	10	61111010	1,690
<b>TXH15</b>	25	10	61111015	1,690
<b>TXH20</b>	25	10	61111020	1,690
<b>TXH25</b>	25	10	61111025	1,690
<b>TXH27</b>	25	10	61111030	1,690
<b>TXH30</b>	25	10	61111035	1,690
<b>TXH40</b>	25	10	61111040	1,690

	L mm	COD.	€ box
<b>TXH09</b>	25	61111005002	4,720
<b>TXH10</b>	25	61111010002	4,720
<b>TXH15</b>	25	61111015002	4,720
<b>TXH20</b>	25	61111020002	4,720
<b>TXH25</b>	25	61111025002	4,720
<b>TXH27</b>	25	61111030002	4,720
<b>TXH30</b>	25	61111035002	4,720
<b>TXH40</b>	25	61111040002	4,720



**SELFPACK**  
2 pcs.

	L mm	COD.	€ box
<b>TXH09</b>	25	61111005010	17,900
<b>TXH10</b>	25	61111010010	17,900
<b>TXH15</b>	25	61111015010	17,900
<b>TXH20</b>	25	61111020010	17,900
<b>TXH25</b>	25	61111025010	17,900
<b>TXH27</b>	25	61111030010	17,900
<b>TXH30</b>	25	61111035010	17,900
<b>TXH40</b>	25	61111040010	17,900



**MINIBOX**  
10 pcs.



### FOCUS ON



Le viti con impronta THX antimanomissione sono spesso utilizzate per l'assemblaggio di piccoli elettrodomestici per escludere rischi di manomissione da personale non qualificato.

Screws with tamper-proof THX tip are often used in the assembly of small household appliances to eliminate the risk of tampering by unqualified people.

Les vis inviolables avec empreinte THX sont souvent utilisées pour l'assemblage de petits appareils électroménagers, afin d'exclure les risques de manipulation par un personnel non qualifié.

Los tornillos con huella THX anti manipulación se usan a menudo para el ensamblaje de pequeños electrodomésticos con el fin de evitar el riesgo de que sean manipulados por personal no especializado.





# 61113 TXH CON FORO

LAME 1/4"E PER VITI TORX® ANTI-MANOMISSIONE  
1/4"E POWER BITS FOR TORX® SCREWS TAMPER-RESISTANT  
EMBOUTS 1/4"E POUR VIS TORX® AVEC SÉCURITÉ  
PUNTAS DE 1/4"E PARA TORNILLOS TORX® ANTIMANIPULACIONES

58/60 HRC

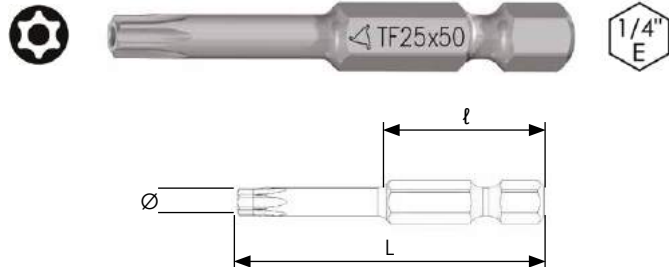

EASYPACK | sacchetto PVC con Euro-hole • PVC bags with Euro-hole

	L mm	l mm	Ø mm	PCS.	COD.	€ cad./each
TXH10	50	25	4	5	61113005	4,180
	75	25	4	5	61113050	9,140
	100	25	4	5	61113055	12,400
	150	25	4	5	61113060	17,900
TXH15	50	25	4	5	61113010	4,180
	75	25	4	5	61113070	9,140
	100	25	4	5	61113075	12,400
	150	25	4	5	61113080	17,900
TXH20	50	25	4,5	5	61113015	4,180
	75	25	4,5	5	61113090	9,140
	100	25	4,5	5	61113095	12,400
	150	25	4,5	5	61113100	17,900
TXH25	50	25	5	5	61113020	4,180
	75	25	5	5	61113110	9,140
	100	25	5	5	61113115	12,400
TXH27	50	25	5,5	5	61113025	4,180
	75	25	5,5	5	61113120	9,140
	100	25	5,5	5	61113125	12,400
TXH30	50	25	6	5	61113030	4,180
	75	25	6	5	61113130	9,140
	100	25	6	5	61113135	12,400
TXH40	50	25	1/4	5	61113035	4,180
	75	25	1/4	5	61113140	9,140

	L mm	COD.	€ box
TXH10	50	61113005002	9,700
TXH15	50	61113010002	9,700
TXH20	50	61113015002	9,700
TXH25	50	61113020002	9,700
TXH27	50	61113025002	9,700
TXH30	50	61113030002	9,700
TXH40	50	61113035002	9,700



SELFPACK  
2 pcs.

	L mm	COD.	€ box
TXH10	50	61113005005	22,000
TXH15	50	61113010005	22,000
TXH20	50	61113015005	22,000
TXH25	50	61113020005	22,000
TXH27	50	61113025005	22,000
TXH30	50	61113030005	22,000
TXH40	50	61113035005	22,000



MINIBOX  
5 pcs.



## FOCUS ON



Le viti con impronta THX antimanomissione sono spesso utilizzate per l'assemblaggio di piccoli elettrodomestici per escludere rischi di manomissione da personale non qualificato.

Screws with tamper-proof THX tip are often used in the assembly of small household appliances to eliminate the risk of tampering by unqualified people.

Les vis inviolables avec empreinte THX sont souvent utilisées pour l'assemblage de petits appareils électroménagers, afin d'exclure les risques de manipulation par un personnel non qualifié.

Los tornillos con huella THX anti manipulación se usan a menudo para el ensamblaje de pequeños electrodomésticos con el fin de evitar el riesgo de que sean manipulados por personal no especializado.



# 1.2 LINEE ESSENTIAL

ESSENTIAL LINES  
LIGNES ESSENTIAL  
LÍNEAS ESSENTIAL

## 61101 TW CONICI

INSERTI 1/4"C PER VITI TORX® CONICHE  
1/4"C BITS FOR TORX® SCREWS WEDGE TIP  
EMBOUTS 1/4"C POUR VIS TORX® EMPREINTE CONIQUE  
PUNTAS DE 1/4"C PARA TORNILLOS TORX® TIPO CÓNICO

58/60 HRC

EASYPACK | sacchetto PVC con Euro-hole • PVC bags with Euro-hole

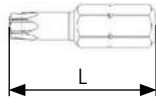

W	L mm	PCS.	COD.	€ cad./each
T06W	25	10	61101005	3,650
T07W	25	10	61101010	3,650
T08W	25	10	61101015	3,650
T09W	25	10	61101020	3,650
T10W	25	10	61101025	1,400
T15W	25	10	61101030	1,400
T20W	25	10	61101035	1,400
T25W	25	10	61101040	1,400
T27W	25	10	61101045	1,400
T30W	25	10	61101050	1,400
T40W	25	10	61101055	1,400

## 61102 TW CONICI

LAME 1/4"E PER VITI TORX® CONICHE  
1/4"E POWER BITS FOR TORX® SCREWS WEDGE TIP  
EMBOUTS 1/4"E POUR VIS TORX® EMPREINTE CONIQUE  
PUNTAS DE 1/4"E PARA TORNILLOS TORX® TIPO CÓNICO

58/60 HRC

EASYPACK | sacchetto PVC con Euro-hole • PVC bags with Euro-hole

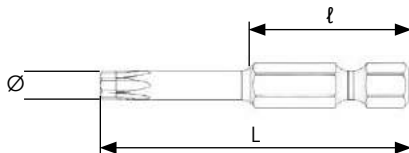

W	L mm	ℓ mm	Ø mm	PCS.	COD.	€ cad./each
T10W	70	25	4	5	61102005	6,430
T15W	70	25	5	5	61102010	6,430
T20W	70	25	5	5	61102015	6,430
T25W	70	25	6	5	61102020	6,430
T27W	70	25	6	5	61102025	6,430
T30W	70	25	6	5	61102030	6,430
T40W	70	25	1/4	5	61102035	6,430



### FOCUS ON

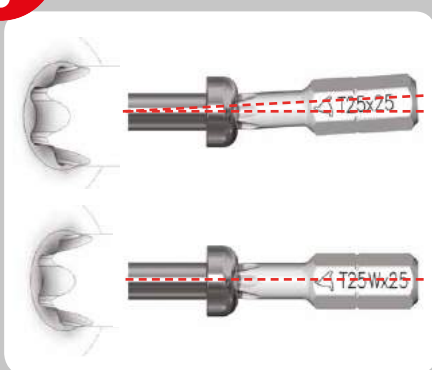

L'impronta TX conica raggiunge il massimo della tolleranza dimensionale.

- Tutto il profilo dell'inserto aderisce alla cava della vite (mentre la standard è sempre leggermente lasca), trasmette più uniformemente la coppia di serraggio e si consuma meno.
- L'inserto rimane in asse con la vite rendendo più veloce e sicura l'avvitatura.

The tapered TX tip reaches the maximum dimensional tolerance.

- The entire profile of the insert sticks to the cavity of the screw, while the standard is always slightly loose, spreading the tightening torque more evenly and contributing significantly to less wear and tear.
- The bit remains in axis with the screw for faster and safer screwing.

L'empreinte TX conique atteint le maximum de la tolérance dimensionnelle.

- Tout le profil de l'embout adhère à la fente de la vis, alors que le modèle standard est légèrement lâche, en transmettant de façon uniforme le couple de serrage et en contribuant de manière significative à la réduction de l'usure.
- L'embout reste dans l'axe avec la vis, en rendant le vissage plus rapide et sûr.

La huella TX cónica alcanza el máximo de la tolerancia dimensional.

- Todo el perfil de la punta se adhiere a la ranura del tornillo, mientras que la estándar está siempre ligeramente floja, transmitiendo de forma más uniforme la par de torsión de cierre y contribuyendo sensiblemente a un menor desgaste.
- La punta queda alineada con el tornillo haciendo que sea más rápido y seguro el atornillado.



# 61139

## TX CON PERNO DI CENTRAGGIO

58/60 HRC

INSERTI 1/4"C CON PERNO DI CENTRAGGIO PER VITI TORX®  
1/4" C WITH CENTERING PIN BITS FOR TORX® SCREWS  
EMBOUITS 1/4" C AVEC GOUPILLE CENTRALE POUR VIS TORX®  
PUNTAS DE 1/4" C CON PERNO CENTRAL PARA TORNILLOS TORX®

EASYPACK | sacchetto PVC con Euro-hole • PVC bags with Euro-hole

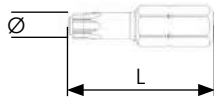

Icon	L mm	PCS.	COD.	€ cad./each
	25	10	61139005	1,450
	25	10	61139010	1,450
	25	10	61139015	1,450
	25	10	61139020	1,450
	25	10	61139025	1,450
	25	10	61139030	1,450
	25	10	61139035	1,450



### FOCUS ON



Le viti con foro di centraggio sono principalmente usate per lavorazioni su legno e plastica. L'utilizzo con lo specifico inserto assicura il perfetto centraggio durante la lavorazione.

Screws with centering hole are mainly used for working on wood and plastic. Use with the specific bit ensures perfect centring during the machining process.

Les vis avec trou de centrage sont principalement utilisées pour l'usage du bois et des matières plastiques. L'utilisation avec l'embout spécifique garantit le centrage parfait pendant l'usinage.

Los tornillos con orificio de centrado se usan principalmente para trabajos sobre madera y plástico. El uso con el específico portapuntas asegura una perfecta alineación durante los trabajos.

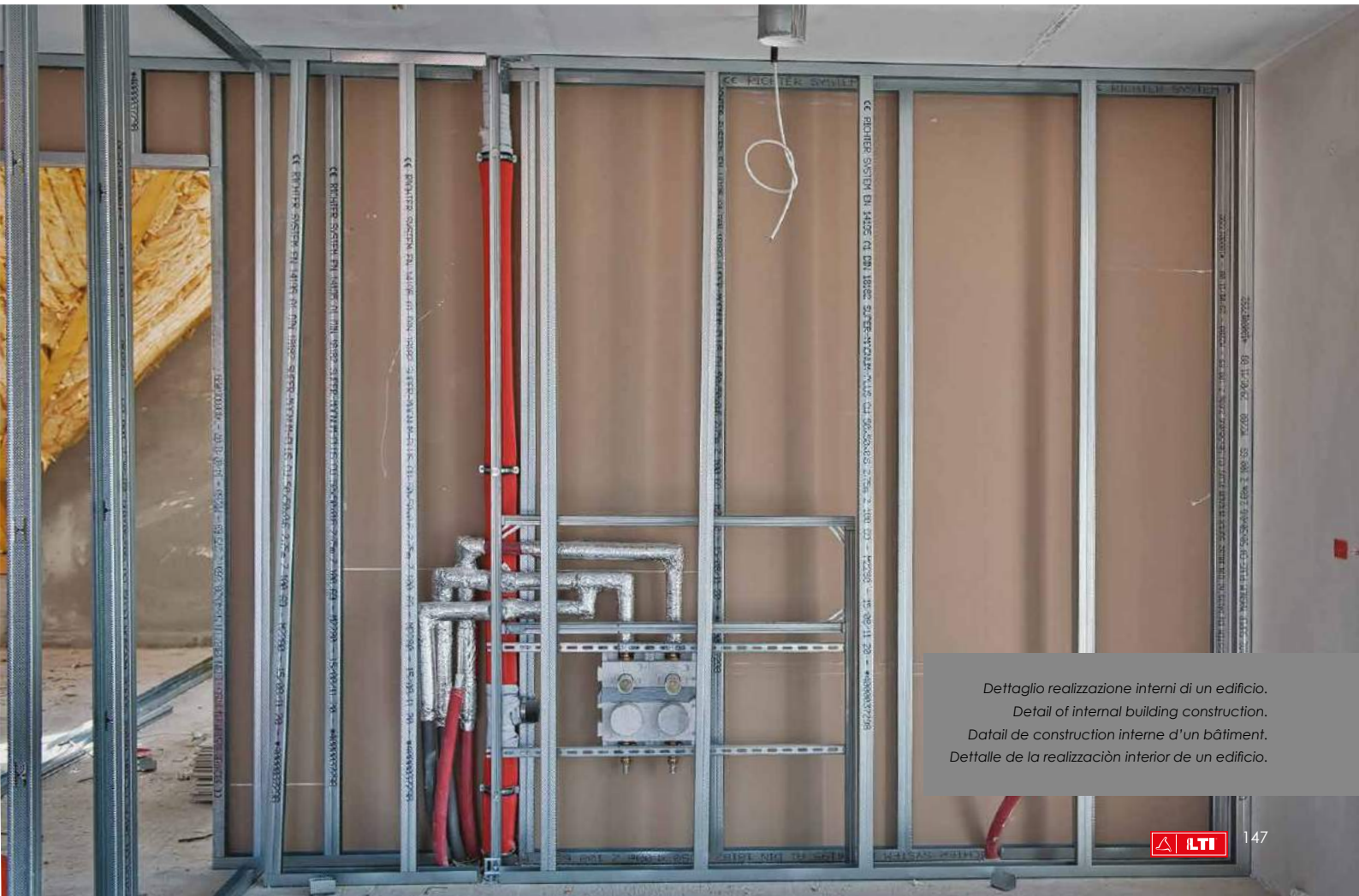

Dettaglio realizzazione interni di un edificio.  
Detail of internal building construction.  
Detail de construction interne d'un bâtiment.  
Dettaglio de la realización interior de un edificio.





# 1.2 LINEE ESSENTIAL

ESSENTIAL LINES  
LIGNES ESSENTIAL  
LÍNEAS ESSENTIAL

## 61123 PER VITI TORX-PLUS® IP

INSERTI 1/4" C PER VITI (IP) TORX-PLUS®  
1/4" C BITS FOR TORX-PLUS® SCREWS (IP)  
EMBOUS 1/4" C POUR VIS (IP) TORX-PLUS®  
PUNTAS DE 1/4" C PARA TORNILLOS (IP) TORX-PLUS®

58/60 HRC

**EASYPACK** | sacchetto PVC con Euro-hole • PVC bags with Euro-hole

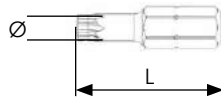

Icon	L mm	PCS.	COD.	€ cad./each
10IP	25	10	61123005	3,490
15IP	25	10	61123010	3,490
20IP	25	10	61123015	3,490
25IP	25	10	61123020	3,490
27IP	25	10	61123025	3,490
30IP	25	10	61123030	3,490
40IP	25	10	61123035	3,490

## 61126 PER VITI TORX-PLUS® IP

LAME 1/4" E PER VITI (IP) TORX-PLUS®  
1/4" E POWER BITS FOR TORX-PLUS® SCREWS (IP)  
EMBOUS 1/4" E POUR VIS (IP) TORX-PLUS®  
PUNTAS DE 1/4" E PARA TORNILLOS (IP) TORX-PLUS®

58/60 HRC

**EASYPACK** | sacchetto PVC con Euro-hole • PVC bags with Euro-hole

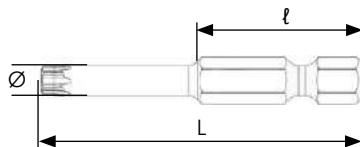

Icon	L mm	l mm	Ø mm	PCS.	COD.	€ cad./each
10IP	50	25	4	5	61126005	6,570
15IP	50	25	4	5	61126010	6,570
20IP	50	25	5	5	61126015	6,570
25IP	50	25	5	5	61126020	6,570
27IP	50	25	6	5	61126025	6,570
30IP	50	25	6	5	61126030	6,570
40IP	50	25	1/4	5	61126035	6,570



### FOCUS ON



Le viti TORX-PLUS® IP nasce come evoluzione dell'impronta TORX® tradizionale per garantire un'elevata resistenza alla coppia di torsione. Questo tipo di impronta viene utilizzata in campo meccanico e per il serraggio degli utensili da tornio.

TORX-PLUS® IPR screws are widely used in the field of mechanical assemblies. Their special shape ensures almost absolute inviolability.

Les vis TORX PLUS®-IPR trouvent une large application dans le domaine des assemblages mécaniques. Leur forme spéciale assure une inviolabilité presque absolue.

Los tornillos TORX-PLUS® IPR se utilizan mucho en el campo de los ensamblajes mecánicos. Su particular forma garantiza una inviolabilidad prácticamente absoluta.



# 61121 PER VITI TORX-PLUS® IPR 5 LOBI

INSERTI 1/4" C PER VITI (IPR) TORX-PLUS® ANTI-MANOMISSIONE  
1/4" C BITS FOR TORX-PLUS® TAMPER-RESISTANT SCREWS (IPR)  
EMBOUS 1/4" C POUR VIS (IPR) TORX-PLUS® AVEC SÉCURITÉ  
PUNTAS DE 1/4" C PARA TORNILLOS (IPR) TORX-PLUS® ANTIMANIPULACIONES

58/60 HRC

**EASYPACK** | sacchetto PVC con Euro-hole • PVC bags with Euro-hole

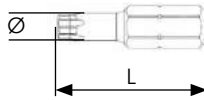

Icon	L mm	Ø mm	PCS.	COD.	€ cad./each	
	10	25	2,7	10	61121005	2,390
	15	25	3,3	10	61121010	2,390
	20	25	3,9	10	61121015	2,390
	25	25	4,3	10	61121020	2,390
	27	25	4,9	10	61121025	2,390
	30	25	5,5	10	61121030	2,390
	40	25	6,3	10	61121035	2,390



## FOCUS ON



Le viti TORX-PLUS® IPR trovano vasta applicazione nel campo degli assemblaggi meccanici. La loro particolare forma garantisce un'inviolabilità quasi assoluta.

TORX-PLUS® IP screws come from the evolution of the traditional TORX® tip to ensure high resistance to torsional stress. This type of tip is used in the mechanical field and to clamp turning tools.

Les vis TORX-PLUS® IP sont une évolution de l'empreinte TORX® traditionnelle pour fournir une résistance élevée au couple de torsion. Ce type d'empreinte est utilisé dans la mécanique et pour le serrage d'outils de tournage.

Los tornillos TORX-PLUS® IP nacen como evolución de la huella TORX® tradicional para garantizar una gran resistencia a la par de torsión. Este tipo de huella se utiliza en el campo mecánico para el cierre de los utensilios para el torno.

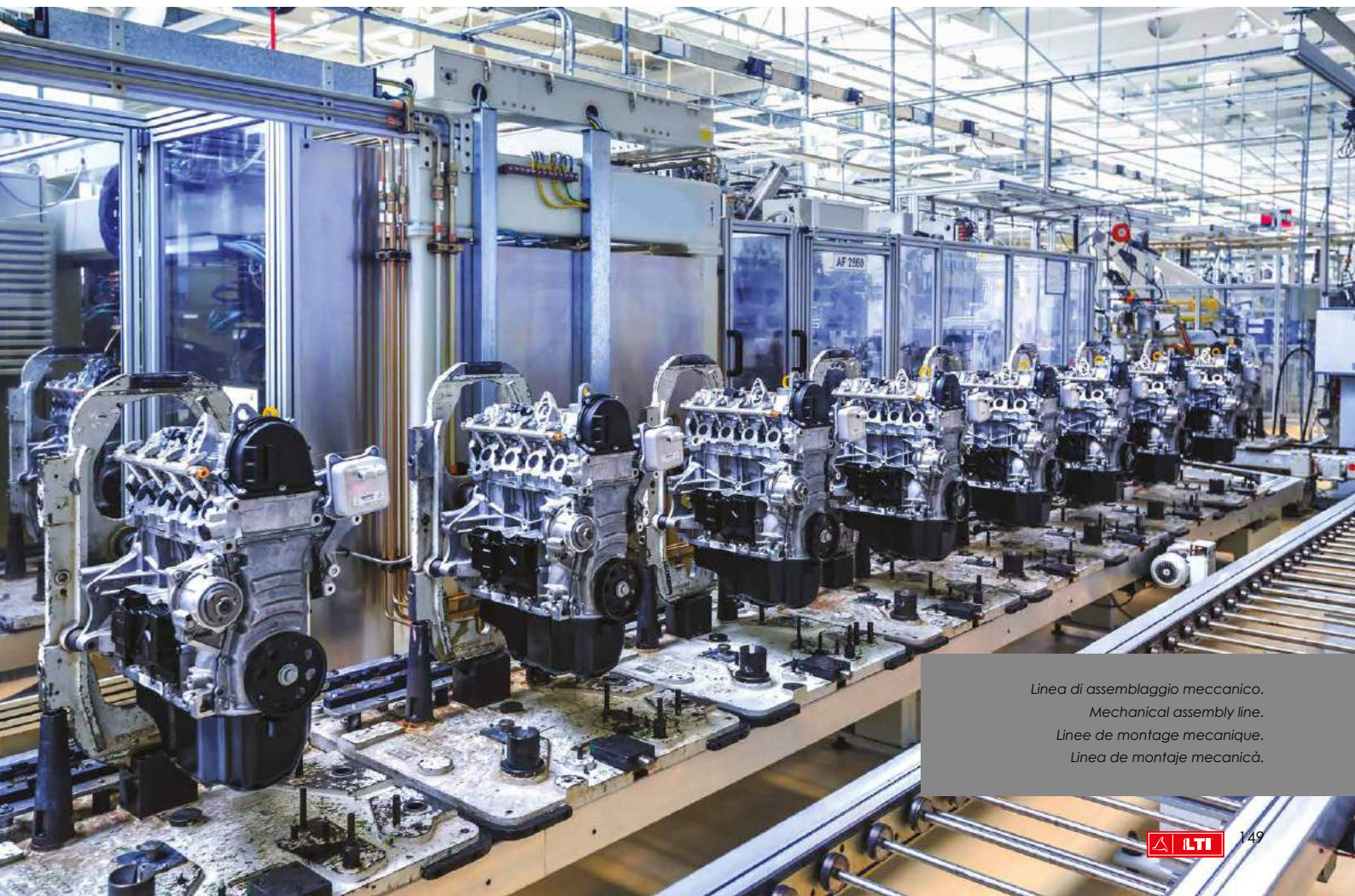

Linea di assemblaggio meccanico.  
Mechanical assembly line.  
Linee de montage mecanique.  
Linea de montaje mecánica.





# 1.2 LINEE ESSENTIAL

ESSENTIAL LINES  
LIGNES ESSENTIAL  
LÍNEAS ESSENTIAL

## 61001 ESAGONO

INSERTI 1/4" C ESAGONALI  
1/4" C HEXAGONAL BITS  
EMBOUTS 1/4" C 6 PANS  
PUNTAS DE 1/4" C HEXAGONALES

58/60 HRC

**EASYPACK** | sacchetto PVC con Euro-hole • PVC bags with Euro-hole

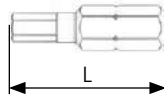

Ø	L mm	PCS.	COD.	€ cad./each
1,5	25	10	61001005	1,180
2	25	10	61001010	1,180
2,5	25	10	61001015	1,180
3	25	10	61001020	1,180
4	25	10	61001025	1,180
5	25	10	61001030	1,180
6	25	10	61001035	1,180
7	25	10	61001040	1,800
8	25	10	61001045	1,800
10	25	10	61001050	2,200

Ø	L mm	COD.	€ box
1,5	25	61001005002	3,700
2	25	61001010002	3,700
2,5	25	61001015002	3,700
3	25	61001020002	3,700
4	25	61001025002	3,700
5	25	61001030002	3,700
6	25	61001035002	3,700
8	25	61001045002	6,160
10	25	61001050002	9,300



**SELPACK**  
2 pcs.

Ø	L mm	COD.	€ box
1,5	25	61001005010	13,400
2	25	61001010010	13,400
2,5	25	61001015010	13,400
3	25	61001020010	13,400
4	25	61001025010	13,400
5	25	61001030010	13,400
6	25	61001035010	13,400
8	25	61001045010	27,200
10	25	61001050010	44,600



**MINIBOX**  
10 pcs.



# 61006 ESAGONO

LAME 1/4"E ESAGONALI  
1/4"E HEXAGONAL POWER BITS  
EMBOUS 1/4"E 6 PANS  
PUNTAS DE 1/4"E HEXAGONALES

58/60 HRC

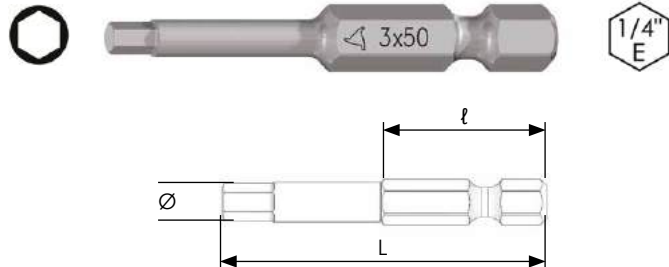

**EASYPACK** | sacchetto PVC con Euro-hole • PVC bags with Euro-hole

Ø	L mm	l mm	Ø mm	PCS.	COD.	€ cad./each
1,5	50	25	3	5	61006100	2,230
	70	25	3	5	61006105	6,427
2	50	25	3	5	61006005	2,350
	70	25	3	5	61006010	3,100
2,5	50	25	3	5	61006015	2,350
	70	25	4	5	61006020	3,100
	100	25	4	5	61006025	6,780
3	150	25	4	5	61006115	12,400
	50	25	4	5	61006030	2,350
	70	25	4	5	61006035	3,100
3	100	25	4	5	61006040	6,780
	127	25	4	5	61006120	9,910
	150	25	4	5	61006125	12,400
	50	25	5	5	61006045	2,350
4	70	25	5	5	61006050	3,100
	100	25	5	5	61006055	6,780
	127	25	5	5	61006130	9,910
	150	25	5	5	61006135	12,400
4	180	25	5	5	61006140	17,200
	50	25	6	5	61006060	2,350
	70	25	6	5	61006065	3,100
	100	25	6	5	61006070	6,780
5	127	25	6	5	61006150	9,910
	150	25	6	5	61006155	12,400
	180	25	6	5	61006157	17,200
	50	25	1/4	5	61006075	2,350
5	70	25	1/4	5	61006080	3,100
	100	25	1/4	5	61006085	6,780
	127	25	1/4	5	61006165	9,910
	150	25	1/4	5	61006170	12,400
6	180	25	1/4	5	61006175	17,200
	50	25	8	5	61006185	2,950
	70	25	8	5	61006190	5,230
	50	25	5/16	5	61006090	2,950
8	70	25	5/16	5	61006095	5,230
	50	25	10	5	61006200	3,750
10	70	25	10	5	61006205	10,800

1.2



Ø	L mm	COD.	€ box
2,5	50	61006015002	6,030
3	50	61006030002	6,030
4	50	61006045002	6,030
5	50	61006060002	6,030
6	50	61006075002	6,030
8	50	61006090002	7,230



**SELPACK**  
2 pcs.



**MINIBOX**  
5 pcs.

Ø	L mm	COD.	€ box
2,5	50	61006015005	12,800
3	50	61006030005	12,800
4	50	61006045005	12,800
5	50	61006060005	12,800
6	50	61006075005	12,800
8	50	61006090005	16,100



# 1.2 LINEE ESSENTIAL

ESSENTIAL LINES  
LIGNES ESSENTIAL  
LÍNEAS ESSENTIAL

## 61004 ESAGONO SFERICO

INSERTI 1/4" C ESAGONALI IMPRONTA TIPO SFERICO  
1/4" C HEXAGONAL BALL TIP BITS  
EMBOUTS 1/4" C 6 PANS EMPREINTE SPHÉRIQUE  
PUNTAS DE 1/4" C HUELLA TIPO ESFÉRICO

58/60 HRC

**EASYPACK** | sacchetto PVC con Euro-hole • PVC bags with Euro-hole

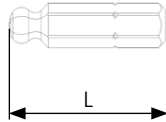

Ø	L mm	Ø mm	PCS.	COD.	€ cad./each
3	25		10	61004005	2,660
4	25		10	61004010	2,660
5	25		10	61004015	2,660
6	25		10	61004020	2,660



### FOCUS ON

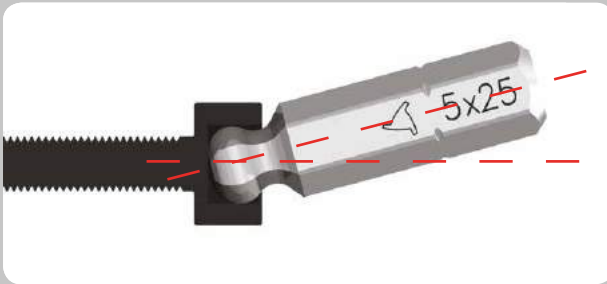

L'inserto tipo sferico permette di avvitare in posizione non rettilinea o disagiata. L'inclinazione massima di lavoro è 15°.

The ball-type bit allows screwing in a crooked or awkward position. The maximum working slope is 15°.

L'embout de type sphérique permet de visser en position penchée ou difficile. L'inclinaison maximale de travail est de 15°.

La punta tipo esférica permite el atornillado en posición no rectilínea o difícil. La inclinación máxima de trabajo es de 15°.

## 61007 ESAGONO SFERICO

LAME 1/4" E ESAGONALI IMPRONTA TIPO SFERICO  
1/4" E HEXAGONAL POWER BALL TIP BITS  
EMBOUTS 1/4" E 6 PANS EMPREINTE SPHÉRIQUE  
PUNTAS DE 1/4" E HUELLA TIPO ESFÉRICO

58/60 HRC

**EASYPACK** | sacchetto PVC con Euro-hole • PVC bags with Euro-hole

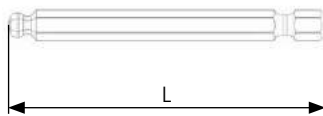

Ø	L mm	PCS.	COD.	€ cad./each
2	75	5	61007005	5,330
2,5	75	5	61007010	5,330
3	75	5	61007015	5,330
	150	5	61007035	15,400
4	75	5	61007020	5,330
	160	5	61007040	15,400
5	75	5	61007025	5,330
	150	5	61007045	15,400
6	75	5	61007030	5,330
	150	5	61007050	15,400





## 61002 ESAGONO CON FORO

INSERTI 1/4"C ESAGONALI ANTI-MANOMISSIONE  
1/4"C HEXAGONAL TAMPER-RESISTANT BITS  
EMBOUS 1/4"C 6 PANS AVEC SÉCURITÉ  
PUNTAS DE 1/4"C HEXAGONALES ANTIMANIPULACIONES

58/60 HRC

**EASYPACK** | sacchetto PVC con Euro-hole • PVC bags with Euro-hole

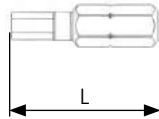

Ø	L mm	PCS.	COD.	€ cad./each
2	25	10	61002004	2,760
2,5	25	10	61002005	2,760
3	25	10	61002010	2,760
4	25	10	61002015	2,760
5	25	10	61002020	2,760
6	25	10	61002025	2,760

1.2



## 61003 ESAGONO (POLLICI)

INSERTI 1/4"C ESAGONALI MISURE IN POLLICI  
1/4"C HEXAGONAL BITS MEASUREMENTS INCHES SIZES  
EMBOUS 1/4"C 6 PANS DIMENSIONS EN POUÇES  
PUNTAS DE 1/4"C HEXAGONALES MEDIDAS EN PULGADAS

58/60 HRC

**EASYPACK** | sacchetto PVC con Euro-hole • PVC bags with Euro-hole

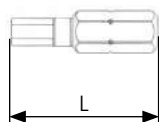

Ø	L mm	Ø mm	PCS.	COD.	€ cad./each
1/16"	25	1,58	10	61003005	1,990
1/8"	25	3,17	10	61003010	1,990
5/32"	25	3,97	10	61003015	1,990
3/16"	25	4,76	10	61003020	1,990
7/32"	25	5,55	10	61003025	1,990
1/4"	25	6,35	10	61003030	1,990



# 1.2 LINEE ESSENTIAL

ESSENTIAL LINES  
LIGNES ESSENTIAL  
LÍNEAS ESSENTIAL

**61021**

**TAGLIO**

INSERTI 1/4" C A TAGLIO  
1/4" C SLOTTED BITS  
EMBOUTS 1/4" C À TÊTE FENDUE  
PUNTAS DE 1/4" C DE CORTE

57/60 HRC

**EASYPACK** | sacchetto PVC con Euro-hole • PVC bags with Euro-hole

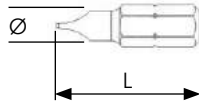

Ø mm	L mm	PCS.	COD.	€ cad./each	
0,5	3	25	10	61021005	1,100
0,6	3,5	25	10	61021010	1,100
0,6	4	25	10	61021015	1,100
0,6	4,5	25	10	61021020	1,100
0,8	5	25	10	61021025	1,100
0,8	5,5	25	10	61021035	1,100
1	5,5	25	10	61021030	1,100
1	6	25	10	61021040	1,100
1,2	6,5	25	10	61021045	1,100
1,2	8	25	10	61021050	1,960
1,6	8	25	10	61021054	1,960

Ø mm	L mm	COD.	€ box	
0,5	3	25	61021005002	3,540
0,6	3,5	25	61021010002	3,540
0,6	4	25	61021015002	3,540
0,6	4,5	25	61021020002	3,540
0,8	5	25	61021025002	3,540
0,8	5,5	25	61021035002	3,540
1,2	6,5	25	61021045002	3,540
1,2	8	25	61021050002	5,250
1,6	8	25	61021054002	5,250



**SELFPAK**  
2 pcs.



**MINIBOX**  
10 pcs.

Ø mm	L mm	COD.	€ box	
0,5	3	25	61021005010	12,600
0,6	3,5	25	61021010010	12,600
0,6	4	25	61021015010	12,600
0,6	4,5	25	61021020010	12,600
0,8	5	25	61021025010	12,600
0,8	5,5	25	61021035010	12,600
1,2	6,5	25	61021045010	12,600
1,2	8	25	61021050010	21,300
1,6	8	25	61021054010	21,300



# 61023 TAGLIO

LAME 1/4"E A TAGLIO  
1/4"E SLOTTED POWER BITS  
EMBOUS 1/4"E À TÊTE FENDUE  
PUNTAS DE 1/4"E DE CORTE

57/60 HRC

**EASYPACK** | sacchetto PVC con Euro-hole • PVC bags with Euro-hole

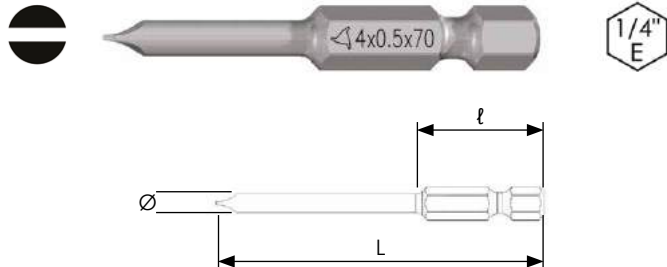

Ø mm	L mm	l mm	PCS.	COD.	€ cad./each	
0,5	3	50	25	5	61023005	2,820
	3	70	25	5	61023010	4,560
0,6	3,5	50	25	5	61023015	2,820
	3,5	70	25	5	61023020	4,560
0,5	4	50	25	5	61023025	2,820
	4	70	25	5	61023030	4,560
	4	100	25	5	61023115	8,570
0,6	4,5	50	25	5	61023035	2,820
	4,5	70	25	5	61023040	4,560
	4,5	100	25	5	61023120	8,570
0,8	5	50	25	5	61023045	2,820
	5	70	25	5	61023050	4,560
	5	100	25	5	61023125	8,570
0,8	5,5	50	25	5	61023055	2,820
	5,5	70	25	5	61023060	4,560
1	6	50	25	5	61023065	2,820
	6	70	25	5	61023070	4,560
1,2	6	100	25	5	61023130	8,570
	6,5	50	25	5	61023075	2,820
1,2	6,5	70	25	5	61023080	4,560
	8	50	25	5	61023085	3,430
1,2	8	70	25	5	61023090	5,870

1.2



Ø mm	L mm	COD.	€ box	
0,5	3	50	61023005002	6,970
0,6	3,5	50	61023015002	6,970
0,5	4	50	61023025002	6,970
0,6	4,5	50	61023035002	6,970
0,8	5	50	61023045002	6,970
0,8	5,5	50	61023055002	6,970
1,2	6,5	50	61023075002	6,970
1,2	8	50	61023085002	8,200



**SELFPACK**  
2 pcs.



**MINIBOX**  
5 pcs.

Ø mm	L mm	COD.	€ box	
0,5	3	50	61023005005	15,300
0,6	3,5	50	61023015005	15,300
0,5	4	50	61023025005	15,300
0,6	4,5	50	61023035005	15,300
0,8	5	50	61023045005	15,300
0,8	5,5	50	61023055005	15,300
1,2	6,5	50	61023075005	15,300
1,2	8	50	61023085005	20,000



# 1.2 LINEE ESSENTIAL

ESSENTIAL LINES  
LIGNES ESSENTIAL  
LÍNEAS ESSENTIAL

**61022**

## TAGLIO PER BUSSOLE GUIDA

58/60 HRC

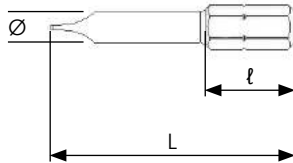

INSERTI 1/4" C A TAGLIO TIPO LUNGO PER BUSSOLE GUIDA  
1/4" C LONG SLOTTED BITS FOR FINDER SLEEVES  
EMBOUS 1/4" C À TÊTE FENDUE LONGS POUR DOUILLES DE GUIDAGE  
PUNTAS DE 1/4" C DE CORTE TIPO LARGO PARA LLAVES DE VASO DE GUÍA

**EASYPACK** | sacchetto PVC con Euro-hole • PVC bags with Euro-hole

Ø mm	L mm	ℓ mm	PCS.	COD.	€ cad./each	
0,5	3	39	12	5	61022005	2,410
0,5	4	39	12	5	61022015	2,410
0,6	3,5	39	12	5	61022010	2,410
0,6	4,5	39	12	5	61022020	2,410
0,8	5	39	12	5	61022025	2,410
0,8	5,5	39	12	5	61022030	2,410
1	6	39	12	5	61022035	2,410
1,2	6,5	39	12	5	61022040	2,410
1,2	7,5	39	12	5	61022045	3,620
1,2	8	39	12	5	61022050	3,620
1,6	8,5	39	12	5	61022055	3,990
1,6	9	39	12	5	61022060	4,820

**61025**

## BUSSOLE GUIDA

58/60 HRC



BUSSOLE GUIDA PER VITI A TAGLIO  
FINDER SLEEVES FOR SLOTTED SCREWS  
DOUILLES DE GUIDAGE POUR VIS À TÊTE FENDUE  
LLAVES DE VASO DE GUÍA PARA TORNILLOS DE CORTE

**EASYPACK** | sacchetto PVC con Euro-hole • PVC bags with Euro-hole

Ø	L mm	Ø mm <sub>1</sub>	PCS.	COD.	€ cad./each
3	47	4,1	5	61025005	42,900
3,5	47	4,6	5	61025010	42,900
4	47	5,1	5	61025015	42,900
4,5	47	5,6	5	61025020	42,900
5	47	6,1	5	61025025	42,900
5,5	47	6,6	5	61025030	42,900
6	47	7,1	5	61025035	42,900
6,5	47	7,6	5	61025040	42,900
7	47	8,1	5	61025045	42,900
7,5	47	8,6	5	61025050	42,900
8	47	9,1	5	61025055	42,900
8,5	47	9,6	5	61025060	42,900
9	47	10,1	5	61025065	42,900



### FOCUS ON



Queste bussole evitano che la vite a taglio scappi dalla lama durante l'avvitatura e sono appositamente disegnate per essere utilizzate con inserti COD. 61022 e portainseriti COD. 62012 o COD. 62014.

These sockets prevent the slotted screw from coming out of the blade during screwing. They are specifically designed to be used with bits, code 61022 and bit holders, code 62012 or code 62014.

Ces douilles empêchent que la vis à fente s'échappe de la lame pendant le vissage. Elles sont spécialement conçues pour être utilisées avec des embouts COD. 61022 et porte-embouts COD. 62012 ou COD. 62014.

Estos vasos evitan que el tornillo de corte se escape de la lama durante la operación de atornillado y han sido diseñadas aposta para ser usadas con puntas COD. 61022 y porta puntas COD. 62012 o COD. 62014.



## FOCUS ON

1.2



**PHILLIPS®**

PHILLIPS® è un marchio registrato di PHILLIPS SCREW COMPANY, fondata da Hensy F. Phillips nel 1934 e cominciò ad essere largamente utilizzata nel 1940 dalla General Motors per l'assemblaggio delle Cadillac. La sua caratteristica principale sta nell'essere autocentrante, è quindi particolarmente indicata negli assemblaggi industriali su linee automatizzate.

PHILLIPS® is a registered trademark of PHILLIPS SCREW COMPANY, which was founded by Henry F. Phillips in 1934. The Phillips screw began to be widely used in 1940 by General Motors for the assembly of the Cadillac. Its self-centring feature makes it particularly suitable for automatic assembly lines.

PHILLIPS® est une marque déposée de PHILLIPS SCREW COMPANY, fondée par Henry F. Phillips en 1934 et a commencé à être largement utilisée en 1940 par General Motors pour l'assemblage des Cadillac. Sa principale caractéristique est d'être auto-centreuse. Elle est donc particulièrement adaptée au montage sur des lignes automatisées.

PHILLIPS® es una marca registrada de PHILLIPS SCREW COMPANY, fundada por Hensy F. Phillips en 1934 y empezó a ser muy usada en 1940 por General Motors para el ensamblaje de los Cadillac. Su característica principal es su centrado automático; por lo tanto es particularmente indicado en los ensamblajes industriales sobre líneas automatizadas.



**POZIDRIV®**

POZIDRIV® è un marchio registrato di PHILLIPS SCREW COMPANY e venne sviluppato agli inizi degli anni '60. Si differenzia dall'impronta PHILLIPS® per avere una doppia serie di creste a croce; le creste principali hanno spessore costante che evita l'effetto di Come-Out. POZIDRIV® trova maggior impiego nel settore del legno.

POZIDRIV® is a registered trademark of PHILLIPS SCREW COMPANY and was developed in the early sixties. Unlike the PHILLIPS® tip, it has two series of cross-shaped ridges; the main ridges have a constant thickness that minimises the come-out effect. POZIDRIV® is widely used in the wood and timber industry.

POZIDRIV® est une marque déposée de PHILLIPS SCREW COMPANY et a été développée au début des années 60. Elle se différencie de l'impréinte PHILLIPS® avec sa double série de striures cruciformes. Les striures principales ont une épaisseur constante qui évite l'effet de sortie. POZIDRIV® s'utilise surtout dans le secteur du bois.

POZIDRIV® es una marca registrada de PHILLIPS SCREW COMPANY y se desarrolló a principios de los años 60. Se diferencia de la huella PHILLIPS® porque tiene una doble serie de crestas en forma de cruz; la crestas principales tienen un espesor constante que evita el efecto de salida (Come-out). POZIDRIV® se emplea sobre todo en el sector de la madera.



**TORX®**

TORX® è un marchio registrato di ACCUMENT GLOBAL TECHNOLOGIES e brevettato nel 1967 da Camcar Textron. TORX® sopporta coppie più elevate rispetto alle viti PH a parità di dimensioni. Ha largo utilizzo in campo automotive. Le sue varianti sono: con foro (TXH), TORX ALIGN® (conico, TW), TORX PLUS® (IP), TORX PLUS® con foro (IPR).

TORX® is a registered trademark of ACCUMENT GLOBAL TECHNOLOGIES and was patented by Camcar Textron in 1967. TORX® supports higher torques than PH screws of the same size. It is widely used in the automotive industry. It comes in the following versions: with slot (TXH), TORX ALIGN® (tapered, TW), TORX PLUS® (IP), TORX PLUS® with slot (IPR).

TORX® est une marque déposée d'ACCUMENT GLOBAL TECHNOLOGIES et brevetée en 1967 par Camcar Textron. TORX® supporte des couples plus élevés que les vis PH de la même taille. Elle est largement utilisée dans le secteur de l'automobile. Ses versions sont : avec trou (TXH), TORX ALIGN® (conique, TW), TORX PLUS® (IP), TORX PLUS® avec trou (IPR).

TORX® es una marca registrada de ACCUMENT GLOBAL TECHNOLOGIES, patentado en 1967 por Camcar Textron. TORX® soporta par de torsión más elevadas con respecto a los tornillos PH a paridad de dimensiones. Se emplea mucho en el sector del Automóvil. Sus variantes son: con orificio (TXH), TORX ALIGN® (cónico, TW), TORX PLUS® (IP) y TORX PLUS® con orificio (IPR).



**ESAGONO**

La vite con cava esagonale, inventata da Mr. W.G. Allen (1910), prende il nome italiano dalle Officine Egidio Brugola di Lissone che per prime la produssero e distribuirono in Italia. È utilizzata su viti con filettatura metrica ed impiegata principalmente in ambito meccanico, automotive e/o carpenteria metallica.

The hex socket screw was invented by W.G. Allen in 1910, the Italian name comes from the founder of the Officine Egidio Brugola of Lissone who first produced and marketed it in Italy. It is used on screws with metric thread, mainly in the mechanical, automotive and/or metal carpentry industries.

La vis à six pans creux fut inventée par Monsieur W.G. Allen en 1910. Le nom italien dérive du fondateur des Officine Egidio Brugola de Lissone qui la produisit et la commercialisa en premier en Italie. Elle est utilisée sur des vis avec filetage métrique et est principalement employée en mécanique, automobile et/ou charpenterie métallique.

El tornillo con ranura hexagonal fue inventado por Mr. W.G. Allen en 1910. El nombre italiano proviene del fundador de los Talleres Egidio Brugola de Lissone que fue el primero que lo produjo y vendió en Italia. Se usa sobre tornillos con rosca métrica y principalmente se emplea en el campo mecánico, del automóvil y/o en la carpintería metálica.



**TAGLIO**

Le prime tracce di viti con intaglio risalgono al tardo Medioevo. Le prime documentazioni si trovano nel Housebook medievale del castello di Wolfegg in Germania, in un manoscritto del 1490. Vengono oggi utilizzate soprattutto in ambito elettrico ed elettronico.

The first traces of slotted head screws date back to the late medieval period. Documentation was found in the Medieval Housebook of the castle of Wolfegg - Germany, a manuscript of 1490. Today, they are used mainly for electrical and electronic applications.

Les premières traces de vis à fente remontent à la fin du moyen-âge. On en trouve trace dans un manuscrit de 1490, dans le Housebook médiéval du château de Wolfegg - Allemagne. Elles sont maintenant utilisées surtout dans les équipements électriques et électroniques.

Los primeros tornillos provistos de corte se remontan a la tardía Edad Media. Hay documentos presentes en el Housebook de la Edad Media del castillo de Wolfegg - Alemania, un manuscrito de 1490. Hoy en día se usan sobre todo en el campo eléctrico y electrónico.





# 1.2 LINEE ESSENTIAL

ESSENTIAL LINES  
LIGNES ESSENTIAL  
LÍNEAS ESSENTIAL

## 61029 PLUS/MINUS TAGLIO + PH

INSERTI 1/4" C IMPRONTA COMBINATA TAGLIO / PH  
1/4" C BITS COMBINED SLOTTED / PH TIP  
EMBOUITS 1/4" C EMPREINTE COMBINÉE TÊTE FENDUE/PH  
PUNTAS DE 1/4" C HUELLA COMBINADA CORTE / PH

57/60 HRC

EASYPACK | sacchetto PVC con Euro-hole • PVC bags with Euro-hole

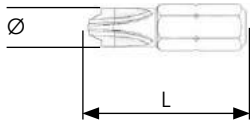

	L mm	PCS.	COD.	€ cad./each
PH1	25	10	61029005	2,150
PH2	25	10	61029010	2,150
PH3	25	10	61029015	2,150



	L mm	COD.	€ box
PH1	25	61029005002	5,630
PH2	25	61029010002	5,630
PH3	25	61029015002	5,630

SELPACK  
2 pcs.



	L mm	COD.	€ box
PH1	25	61029005010	24,000
PH2	25	61029010010	24,000
PH3	25	61029015010	24,000

MINIBOX  
10 pcs.

## 61029 PLUS/MINUS TAGLIO + PH

LAME 1/4" E IMPRONTA COMBINATA TAGLIO / PH  
1/4" E POWER BITS COMBINED SLOTTED / PH TIP  
EMBOUITS 1/4" E EMPREINTE COMBINÉE TÊTE FENDUE/PH  
PUNTAS DE 1/4" E HUELLA COMBINADA CORTE / PH

57/60 HRC

EASYPACK | sacchetto PVC con Euro-hole • PVC bags with Euro-hole

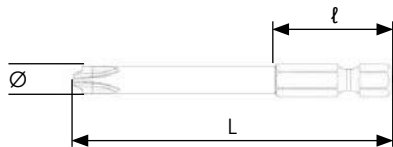

	L mm	l mm	PCS.	COD.	€ cad./each
PH1	70	25	5	61029105	5,630
PH2	70	25	5	61029110	5,630
PH3	70	25	5	61029115	5,630



	L mm	COD.	€ box
PH1	70	61029105002	12,600
PH2	70	61029110002	12,600
PH3	70	61029115002	12,600

SELPACK  
2 pcs.



	L mm	COD.	€ box
PH1	70	61029105005	31,500
PH2	70	61029110005	31,500
PH3	70	61029115005	31,500

MINIBOX  
5 pcs.



## 61030 PLUS/MINUS TAGLIO + PZ

INSERTI 1/4" C IMPRONTA COMBINATA TAGLIO / PZ  
1/4" C BITS COMBINED SLOTTED / PZ TIP  
EMBOUTS 1/4" C EMPREINTE COMBINÉE TÊTE FENDUE/ PZ  
PUNTAS DE 1/4" C HUELLA COMBINADA CORTE / PZ

57/60 HRC

EASYPACK | sacchetto PVC con Euro-hole • PVC bags with Euro-hole

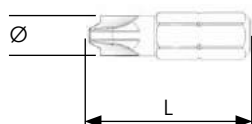

	L mm	PCS.	COD.	€ cad./each
<b>PZ1</b>	25	10	61030005	2,150
<b>PZ2</b>	25	10	61030010	2,150
<b>PZ3</b>	25	10	61030015	2,150

1.2



SELPACK  
2 pcs.

	L mm	COD.	€ box
<b>PZ1</b>	25	61030005002	5,630
<b>PZ2</b>	25	61030010002	5,630
<b>PZ3</b>	25	61030015002	5,630



MINIBOX  
10 pcs.

	L mm	COD.	€ box
<b>PZ1</b>	25	61030005010	24,000
<b>PZ2</b>	25	61030010010	24,000
<b>PZ3</b>	25	61030015010	24,000

## 61030 PLUS/MINUS TAGLIO + PZ

LAME 1/4" E IMPRONTA COMBINATA TAGLIO / PZ  
1/4" E POWER BITS COMBINED SLOTTED / PZ TIP  
EMBOUTS 1/4" E EMPREINTE COMBINÉE TÊTE FENDUE/ PZ  
PUNTAS DE 1/4" E HUELLA COMBINADA CORTE / PZ

57/60 HRC

EASYPACK | sacchetto PVC con Euro-hole • PVC bags with Euro-hole



	L mm	l mm	PCS.	COD.	€ cad./each
<b>PZ1</b>	70	25	5	61030105	5,630
<b>PZ2</b>	70	25	5	61030110	5,630
<b>PZ3</b>	70	25	5	61030115	5,630



SELPACK  
2 pcs.

	L mm	COD.	€ box
<b>PZ1</b>	70	61030105002	12,600
<b>PZ2</b>	70	61030110002	12,600
<b>PZ3</b>	70	61030115002	12,600



MINIBOX  
5 pcs.

	L mm	COD.	€ box
<b>PZ1</b>	70	61030105005	31,500
<b>PZ2</b>	70	61030110005	31,500
<b>PZ3</b>	70	61030115005	31,500





# 1.2 LINEE ESSENTIAL

ESSENTIAL LINES  
LIGNES ESSENTIAL  
LÍNEAS ESSENTIAL

## 61133 QUADRO

INSERTI 1/4"C IMPRONTA QUADRA  
1/4"C BITS SQUARE TIP  
EMBOUTS 1/4"C EMPREINTE CARRÉE  
PUNTAS DE 1/4"C HUELLA CUADRADA

58/60 HRC

**EASYPACK** | sacchetto PVC con Euro-hole • PVC bags with Euro-hole

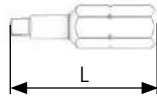
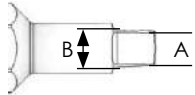

Ø	L mm	A	B	PCS.	COD.	€ cad./each
1 3/32"	25	2,31	2,5	10	61133005	0,940
2 1/8"	25	2,85	3,2	10	61133010	0,940
3 9/64"	25	3,37	3,7	10	61133015	0,940

## 61134 QUADRO

LAME 1/4"E IMPRONTA QUADRA  
1/4"E POWER BITS SQUARE TIP  
EMBOUTS 1/4"E EMPREINTE CARRÉE  
PUNTAS DE 1/4"E HUELLA CUADRADA

58/60 HRC

**EASYPACK** | sacchetto PVC con Euro-hole • PVC bags with Euro-hole

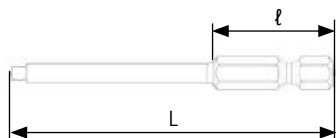
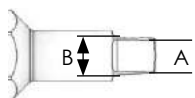

Ø	L mm	l mm	A	B	PCS.	COD.	€ cad./each
1 3/32"	70	25	2,31	2,5	5	61134005	2,680
2 1/8"	70	25	2,85	3,2	5	61134010	2,680
3 9/64"	70	25	3,37	3,7	5	61134015	2,680





## 61122 SPANNER

INSERTI 1/4" C PER VITI SPANNER  
1/4" C BITS FOR SPANNER SCREWS  
EMBOUS 1/4" C POUR VIS SPANNER  
PUNTAS DE 1/4" C PARA TORNILLOS SPANNER

57/60 HRC

**EASYPACK** | sacchetto PVC con Euro-hole • PVC bags with Euro-hole

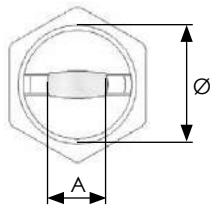



●●	L mm	Ø mm	A	PCS.	COD.	€ cad./each
4	25	3,7	1,50	10	61122005	1,750
6	25	4,4	2,40	10	61122010	1,750
8	25	4,9	2,80	10	61122015	1,750
10	25	6,1	3,30	10	61122020	1,750

1.2

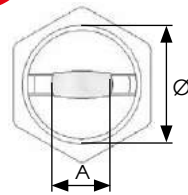

### TIPS



●●	Ø	A	
4	3,7	1,50	2,5x0,45
6	4,4	2,40	3,0x0,5
8	4,9	2,80	4,0x0,7
10	6,1	3,30	5,0x0,8

## 61135 SPANNER

LAME 1/4" E PER VITI SPANNER  
1/4" E POWER BITS FOR SPANNER SCREWS  
EMBOUS 1/4" E POUR VIS SPANNER  
PUNTAS DE 1/4" E PARA TORNILLOS SPANNER

57/60 HRC

**EASYPACK** | sacchetto PVC con Euro-hole • PVC bags with Euro-hole

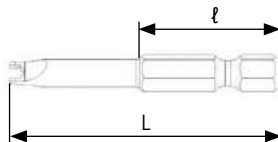
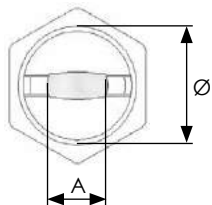
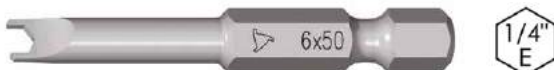

●●	L mm	ℓ mm	Ø mm	A	PCS.	COD.	€ cad./each
4	50	25	3,7	1,50	5	61135005	4,260
6	50	25	4,4	2,40	5	61135010	4,260
8	50	25	4,9	2,80	5	61135015	4,260
10	50	25	6,1	3,30	5	61135020	4,260



### TIPS

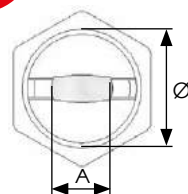

●●	Ø	A	
4	3,7	1,50	2,5x0,45
6	4,4	2,40	3,0x0,5
8	4,9	2,80	4,0x0,7
10	6,1	3,30	5,0x0,8



# 1.2 LINEE ESSENTIAL

ESSENTIAL LINES  
LIGNES ESSENTIAL  
LÍNEAS ESSENTIAL

## 61125 TRI-WING®

INSERTI 1/4" C PER VITI TRI-WING®  
1/4" C BITS FOR TRI-WING® SCREWS  
EMBOUS 1/4" C POUR VIS TRI-WING®  
PUNTAS DE 1/4" C PARA TORNILLOS TRI-WING®

57/60 HRC

**EASYPACK** | sacchetto PVC con Euro-hole • PVC bags with Euro-hole

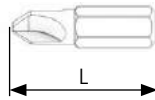
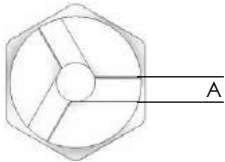

	L mm	A	PCS.	COD.	€ cad./each
1	25	0,6	10	61125005	1,880
2	25	0,75	10	61125010	1,880
3	25	0,95	10	61125015	1,880
4	25	1,1	10	61125020	1,880

## 61137 TRI-WING®

LAME 1/4" E PER VITI TRI-WING®  
1/4" E POWER BITS FOR TRI-WING® SCREWS  
EMBOUS 1/4" E POUR VIS TRI-WING®  
PUNTAS DE 1/4" E PARA TORNILLOS TRI-WING®

57/60 HRC

**EASYPACK** | sacchetto PVC con Euro-hole • PVC bags with Euro-hole

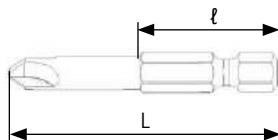
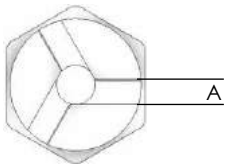

	L mm	l mm	A	PCS.	COD.	€ cad./each
1	50	25	0,6	5	61137005	4,340
2	50	25	0,75	5	61137010	4,340
3	50	25	0,95	5	61137015	4,340
4	50	25	1,1	5	61137020	4,340



## 61124 TORQ-SET®

INSERTI 1/4" C PER VITI TORQ-SET®  
1/4" C BITS FOR TORQ-SET® SCREWS  
EMBOUTS 1/4" C POUR VIS TORQ-SET®  
PUNTAS DE 1/4" C PARA TORNILLOS TORQ-SET®

57/60 HRC

**EASYPACK** | sacchetto PVC con Euro-hole • PVC bags with Euro-hole

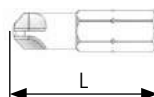
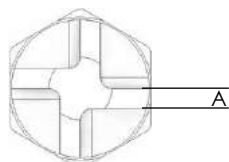

+	L mm	A	PCS.	COD.	€ cad./each
0	25	0,4	10	61124000	1,880
1	25	0,4	10	61124001	1,880
2	25	0,4	10	61124002	1,880
3	25	0,45	10	61124003	1,880
4	25	0,5	10	61124004	1,880
5	25	0,6	10	61124005	1,880
6	25	0,7	10	61124006	1,880
8	25	0,85	10	61124010	1,880
10	25	0,95	10	61124015	1,880
1/4"	25	1,25	10	61124020	2,530
5/16"	32	1,50	10	61124025	3,450

1.2



## 61136 TORQ-SET®

LAME 1/4" E PER VITI TORQ-SET®  
1/4" E POWER BITS FOR TORQ-SET® SCREWS  
EMBOUTS 1/4" E POUR VIS TORQ-SET®  
PUNTAS DE 1/4" E PARA TORNILLOS TORQ-SET®

57/60 HRC

**EASYPACK** | sacchetto PVC con Euro-hole • PVC bags with Euro-hole

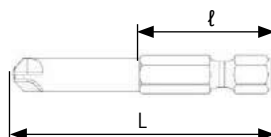
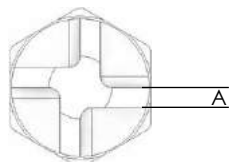

+	L mm	l mm	A	PCS.	COD.	€ cad./each
6	50	25	0,7	5	61136005	4,340
8	50	25	0,85	5	61136010	4,340
10	50	25	0,95	5	61136015	4,340



# 1.2 LINEE ESSENTIAL

ESSENTIAL LINES  
LIGNES ESSENTIAL  
LÍNEAS ESSENTIAL

**61132** XZN

INSERTI 1/4" C PER VITI XZN  
1/4" C BITS FOR XZN SCREWS  
EMBOUS 1/4" C POUR VIS XZN  
PUNTAS DE 1/4" C PARA TORNILLOS XZN

57/60 HRC

**EASYPACK** | sacchetto PVC con Euro-hole • PVC bags with Euro-hole

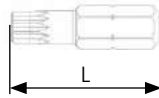
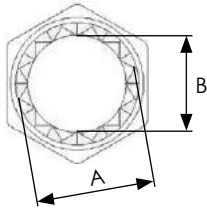

Ø	L mm	A	B	PCS.	COD.	€ cad./each
<b>M4</b>	25	3,80	3,10	10	61132005	1,610
<b>M5</b>	25	4,10	4,00	10	61132010	1,610
<b>M6</b>	25	6,00	5,00	10	61132015	1,610
<b>M8</b>	25	7,20	6,00	10	61132020	2,410
<b>M10</b>	25	9,60	8,00	10	61132025	2,410

**61138** XZN

LAME 1/4" E PER VITI XZN  
1/4" E POWER BITS FOR XZN SCREWS  
EMBOUS 1/4" E POUR VIS XZN  
PUNTAS DE 1/4" E PARA TORNILLOS XZN

57/60 HRC

**EASYPACK** | sacchetto PVC con Euro-hole • PVC bags with Euro-hole

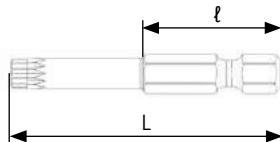
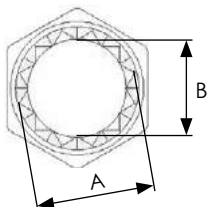

Ø	L mm	l mm	A	B	PCS.	COD.	€ cad./each
<b>M4</b>	50	25	3,80	3,10	5	61138005	4,180
<b>M5</b>	50	25	4,10	4,00	5	61138010	4,180
<b>M6</b>	50	25	6,00	5,00	5	61138015	4,180
<b>M8</b>	50	25	7,20	6,00	5	61138020	4,180
<b>M10</b>	50	25	9,60	8,00	5	61138025	4,180



# 61147 ASSI-SIT

INSERTI 1/4" C PER VITI AW® ASSI-SIT  
 1/4" C BITS FOR AW® ASSI-SIT SCREWS  
 EMBOUTS 1/4" C POUR VIS AW® ASSI-SIT  
 PUNTAS DE 1/4" C PARA TORNILLOS AW® ASSI-SIT

**NEW!**

58/60 HRC

**EASYPACK** | sacchetto PVC con Euro-hole • PVC bags with Euro-hole

1.2

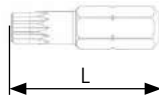
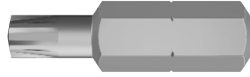

	L mm	PCS.	COD.	€ cad./each
<b>AW10</b>	25	10	61147005	1,900
<b>AW15</b>	25	10	61147010	1,900
<b>AW20</b>	25	10	61147015	1,900
<b>AW25</b>	25	10	61147020	1,900
<b>AW30</b>	25	10	61147025	1,900
<b>AW40</b>	25	10	61147030	1,900



*Interno di un Hangar di fabbricazioni di aeromobili.  
 Interior of an aircraft manufacturing hangar.  
 Intérieur d'un hangar de fabrication d'avions.  
 Interior de un hangar para la fabricación de aeromóviles.*



# 1.2 LINEE ESSENTIAL

ESSENTIAL LINES  
LIGNES ESSENTIAL  
LÍNEAS ESSENTIAL

## 61041 PH DOPPIO

LAME 1/4"E DOPPIA IMPRONTA PHILLIPS®  
1/4"E PHILLIPS® POWER BITS DOUBLE TIP  
EMBOUTS 1/4"E DOUBLE EMPREINTE PHILLIPS®  
PUNTAS DE 1/4"E DOBLE HUELLA PHILLIPS®

58/60 HRC

**EASYPACK** | sacchetto PVC con Euro-hole • PVC bags with Euro-hole



+	L mm	PCS.	COD.	€ cad./each
1 x 1	45	5	61041005	2,280
1 x 1	75	5	61041010	2,550
2 x 2	45	5	61041015	2,280
2 x 2	75	5	61041020	2,550
3 x 3	75	5	61041025	2,550

## 61067 PZ DOPPIO

LAME 1/4"E DOPPIA IMPRONTA POZIDRIV®  
1/4"E POZIDRIV® POWER BITS DOUBLE TIP  
EMBOUTS 1/4"E DOUBLE EMPREINTE POZIDRIV®  
PUNTAS DE 1/4"E DOBLE HUELLA POZIDRIV®

58/60 HRC

**EASYPACK** | sacchetto PVC con Euro-hole • PVC bags with Euro-hole

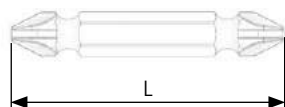

+	L mm	PCS.	COD.	€ cad./each
1 x 1	45	5	61067005	4,130
1 x 1	75	5	61067010	4,420
2 x 2	45	5	61067015	4,130
2 x 2	75	5	61067020	4,420



## 61027 DOPPIO TAGLIO + PH

INSERTI 1/4" DOPPIA IMPRONTA TAGLIO + PH  
1/4" BITS DOUBLE SLOTTED + PH TIP  
EMBOUS 1/4" DOUBLE EMPREINTE TÊTE FENDUE + PH  
PUNTAS DE 1/4"C DOBLE HUELLA CORTE + PH

57/60 HRC

EASYPACK | sacchetto PVC con Euro-hole • PVC bags with Euro-hole

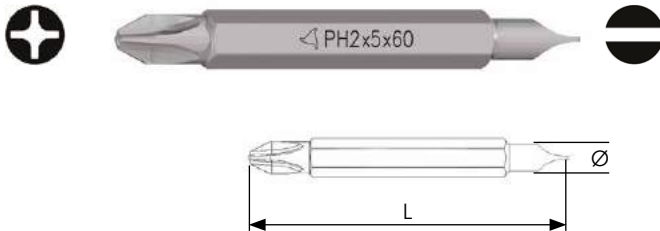

	L mm	Ø	PCS.	COD.	€ cad./each
PH1	60	0,6x4,0	10	61027005	2,010
PH2	60	0,8x5,0	10	61027010	2,010
PH3	60	1,2x7,0	10	61027015	2,010



SELFPACK  
2 pcs.

	L mm	COD.	€ box
PH1	60	61027005002	5,360
PH2	60	61027010002	5,360
PH3	60	61027015002	5,360



MINIBOX  
5 pcs.

	L mm	COD.	€ box
PH1	60	61027005005	11,300
PH2	60	61027010005	11,300
PH3	60	61027015005	11,300

## 61028 DOPPIO TAGLIO + PZ

INSERTI 1/4" DOPPIA IMPRONTA TAGLIO + PZ  
1/4" BITS DOUBLE SLOTTED + PZ TIP  
EMBOUS 1/4" DOUBLE EMPREINTE TÊTE FENDUE + PZ  
PUNTAS DE 1/4"C DOBLE HUELLA CORTE + PZ

57/60 HRC

EASYPACK | sacchetto PVC con Euro-hole • PVC bags with Euro-hole

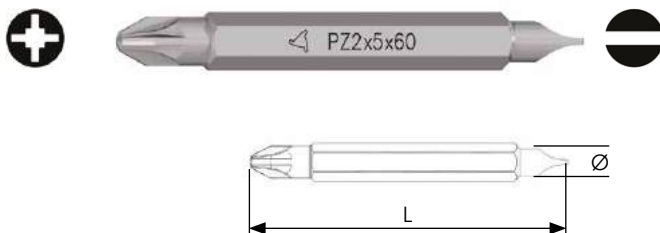

	L mm	Ø	PCS.	COD.	€ cad./each
PZ1	60	0,6x4,0	10	61028005	2,010
PZ2	60	0,8x5,0	10	61028010	2,010
PZ3	60	1,2x7,0	10	61028015	2,010



SELFPACK  
2 pcs.

	L mm	COD.	€ box
PZ1	60	61028005002	5,360
PZ2	60	61028010002	5,360
PZ3	60	61028015002	5,360



MINIBOX  
5 pcs.

	L mm	COD.	€ box
PZ1	60	61028005005	11,300
PZ2	60	61028010005	11,300
PZ3	60	61028015005	11,300





# 1.2 LINEE ESSENTIAL

ESSENTIAL LINES  
LIGNES ESSENTIAL  
LÍNEAS ESSENTIAL

**66002**

**MYBIT 7**

ASSORTIMENTI ESSENTIAL

ASSORTIMENTO 7 PCS. - INSERTI + PORTAINSERTI  
7 PCS. SET - BITS + BIT-HOLDER  
JEU 7 PCS. - EMBOUTS + PORTE-EMBOUTS  
JUEGO DE 7 PCS. - PUNTAS + PORTA PUNTAS



7 pcs.



100 X 120 mm



INCLUSO / INCLUDED  
INCLUDE / INCLUIDO  
COD. 62013005



INCLUSO / INCLUDED  
INCLUDE / INCLUIDO  
COD. 62019020



COD. **66002105**  
€ 10,800

COD. **66002170**  
€ 11,700



PH1  
1pc.



PH2  
1pc.



PZ1  
1pc.

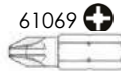

PZ2  
1pc.



0,6x4,5  
1pc.



1,2x6,5  
1pc.



2  
1pc.



2,5  
1pc.

3  
1pc.

4  
1pc.

5  
1pc.

6  
1pc.

COD. **66002115**  
€ 11,800

COD. **66002155**  
€ 24,600



TX10  
1pc.

TX15  
1pc.

TX20  
1pc.

TX25  
1pc.

TX30  
1pc.

TX40  
1pc.



IP10  
1pc.



IP15  
1pc.

IP20  
1pc.

IP25  
1pc.

IP30  
1pc.

IP40  
1pc.

COD. **66002125**  
€ 10,900

COD. **66002160**  
€ 18,600



PH1  
1pc.

PH2  
1pc.

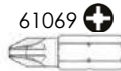

PZ1  
1pc.

PZ2  
1pc.



TX25  
1pc.

TX30  
1pc.



10  
1pc.



15  
1pc.

20  
1pc.

25  
1pc.

30  
1pc.

40  
1pc.

COD. **66002150**  
€ 15,000

COD. **66002165**  
€ 14,400



TXH10  
1pc.

TXH15  
1pc.

TXH20  
1pc.

TXH25  
1pc.

TXH30  
1pc.

TXH40  
1pc.



M4  
1pc.



M5  
2pcs.

M6  
1pc.

M8  
1pc.

M10  
1pc.





66002

# DISPLAY MYBIT 7 ESSENTIAL

ESPOSITORE DA BANCO IN PLEXIGLASS PER 12 BIT-SETS  
12 PCS. BIT-SETS PLEXIGLASS COUNTER DISPLAY  
PRÉSENTOIR EN PLEXIGLAS POUR 12 JEUX D'EMBOUS  
MOSTRADOR DE EXPOSICIÓN IN PLEXIGLASS PARA 12 BIT-SET

COD. 66002108

€ 129,600

12 pcs.



150 X 40 X 195 mm



12 pcs.  
COD. 66002105

COD. 66002118

€ 141,600



12 pcs.  
COD. 66002115

COD. 66002129

€ 130,800



12 pcs.  
COD. 66002125

1.2



66007

# MYBIT 7 POWER ESSENTIAL

ASSORTIMENTO 7 PCS. - INSERTI  
7 PCS. SET - BITS  
JEU 7 PCS. - EMBOUTS  
JUEGO 7 PCS. - PUNTAS

NEW!

7 pcs.



100 X 120 mm



COD. 66007100

€ 14,300

61051 ⊕ L=50mm		61076 ⊕ L=50mm		61079 ⊕ L=50mm		
PH1 1pc.	PH2 1pc.	PZ1 1pc.	PZ2 1pc.	TX25 1pc.	TX30 1pc.	TX40 1pc.

COD. 66007105

€ 10,300

61051 ⊕ L=50mm			61076 ⊕ L=50mm		
PH1 1pc.	PH2 2pcs.	PH3 1pc.	PZ1 1pc.	PZ2 1pc.	PZ3 1pc.



# 1.2 LINEE ESSENTIAL

ESSENTIAL LINES  
LIGNES ESSENTIAL  
LÍNEAS ESSENTIAL

**66005**

**MYBIT 10**

ASSORTIMENTI ESSENTIAL

ASSORTIMENTO 10 PCS. - INSERTI + PORTAINSERI  
10 PCS. SET - BITS + BIT-HOLDER  
JEU 10 PCS. - EMBOUTS + PORTE-EMBOUTS  
JUEGO DE 10 PCS. - PUNTAS + PORTA PUNTAS



10  
pcs.

INCLUSO / INCLUDED  
INCLUDE / INCLUIDO

COD. 62013005



100 X 120 mm



COD. **66005105**  
€ 11,900

COD. **66005170**  
€ 15,400

61043			61069			61021		
PH1	PH2	PH3	PZ1	PZ2	PZ3	0,6x4,5	1,0x5,5	1,2x6,5
1pc.	1pc.	1pc.	1pc.	1pc.	1pc.	1pc.	1pc.	1pc.

61001						
2	2,5	3	4	5	6	8
1pc.	1pc.	1pc.	2pcs.	2pcs.	1pc.	1pc.

COD. **66005115**  
€ 11,700

COD. **66005155**  
€ 19,400

61043			61069			61094		
PH1	PH2	PH3	PZ1	PZ2	PZ3	TX25	TX30	TX40
1pc.	1pc.	1pc.	1pc.	1pc.	1pc.	1pc.	1pc.	1pc.

61111						
TXH09	TXH10	TXH15	TXH20	TXH25	TXH30	TXH40
1pc.	1pc.	1pc.	2pcs.	2pcs.	1pc.	1pc.

COD. **66005125**  
€ 12,100

COD. **66005160**  
€ 33,800

61043		61069		61001		
PH1	PH2	PZ1	PZ2	3	4	5
1pc.	2pc.	1pc.	2pc.	1pc.	1pc.	1pc.

61123					
IP10	IP15	IP20	IP25	IP30	IP40
1pc.	2pcs.	2pcs.	2pcs.	1pc.	1pc.

COD. **66005150**  
€ 14,100

COD. **66005165**  
€ 25,200

61094								
TX06	TX08	TX09	TX10	TX15	TX20	TX25	TX30	TX40
1pc.	1pc.	1pc.	1pc.	1pc.	1pc.	1pc.	1pc.	1pc.

61121							
10	15	20	25	27	30	40	
1pc.	1pc.	2pcs.	2pcs.	1pc.	1pc.	1pc.	



# 66005 DISPLAY MYBIT 10 ESSENTIAL

ESPOSITORE DA BANCO IN PLEXIGLASS PER 12 BIT-SETS  
 12 PCS. BIT-SETS PLEXIGLASS COUNTER DISPLAY  
 PRÉSENTOIR EN PLEXIGLASS POUR 12 JEUX D'EMBOUITS  
 MOSTRADOR DE EXPOSICIÓN IN PLEXIGLASS PARA 12 BIT-SET



12 pcs.

150 X 40 X 195 mm

1.2



COD. **66005109**  
 € 142,800



12 pcs.  
 COD. 66005105

COD. **66005119**  
 € 140,400



12 pcs.  
 COD. 66005115

COD. **66005129**  
 € 145,200



12 pcs.  
 COD. 66005125

COD. **66005154**  
 € 169,200



12 pcs.  
 COD. 66005150



# 1.2 LINEE ESSENTIAL

ESSENTIAL LINES  
LIGNES ESSENTIAL  
LÍNEAS ESSENTIAL

**66006**

**MYBIT 15**

ASSORTIMENTI ESSENTIAL

ASSORTIMENTO 15 PCS. - INSERTI + PORTAINSERI  
15 PCS. SET - BITS + BIT-HOLDER  
JEU 15 PCS. - EMBOUTS + PORTE-EMBOUTS  
JUEGO DE 15 PCS. - PUNTAS + PORTA PUNTAS



15  
pcs.



100 X 167 mm



INCLUSO / INCLUDED  
INCLUDE / INCLUIDO  
COD. 62013005



COD. **66006020**

€ 15,500

<p>61043 </p>			<p>61069 </p>			<p>61021 </p>		
PH1 1pc.	PH2 1pc.	PH3 1pc.	PZ1 1pc.	PZ2 1pc.	PZ3 1pc.	0,6x4,5 1pc.	0,8x5,5 1pc.	1,2x6,5 1pc.
<p>61094 </p>			<p>61051 </p>			<p>61076 </p>		
TX15 1pc.	TX20 1pc.	TX25 1pc.	PH2x70 1pc.			PZ2x70 1pc.		

COD. **66006050**

€ 23,300

<p>61001 </p>					
2 1pc.	2,5 1pc.	3 1pc.	4 1pc.	5 1pc.	6 1pc.
<p>61111 </p>					
TXH10 1pc.	TXH15 1pc.	TXH20 1pc.	TXH25 1pc.	TXH30 1pc.	TXH40 1pc.
<p>61006 </p>					
4x70 1pc.			5x70 1pc.		

COD. **66006055**

€ 44,900

<p>61123 </p>					
IP10 1pc.	IP15 1pc.	IP20 1pc.	IP25 1pc.	IP30 1pc.	IP40 1pc.
<p>61121 </p>					
10 1pc.	15 1pc.	20 1pc.	25 1pc.	30 1pc.	40 1pc.
<p>61126 </p>					
IP20x50 1pc.			IP25x50 1pc.		

COD. **66006060**

€ 27,400

<p>61124 </p>				<p>61125 </p>			
06 1pc.	08 1pc.	10 1pc.	1 1pc.	2 1pc.	3 1pc.	4 1pc.	
<p>61122 </p>				<p>61133 </p>			
4 1pc.	6 1pc.	8 1pc.	10 1pc.	3 1pc.			
<p>61134 </p>							
1x70 1pc.			2x70 1pc.				

**66006**
**DISPLAY MYBIT15**  
**ESSENTIAL**

 ESPOSITORE DA BANCO IN PLEXIGLASS PER 12 BIT-SETS  
 12 PCS. BIT-SETS PLEXIGLASS COUNTER DISPLAY  
 PRÉSENTOIR EN PLEXIGLAS POUR 12 JEUX D'EMBOUITS  
 MOSTRADOR DE EXPOSICIÓN IN PLEXIGLASS PARA 12 BIT-SET

1.2

12  
pcs.

185 X 40 X 195 mm

 COD. **66006024**  
 € 186,000

 12 pcs.  
 COD. 66006020

 COD. **66006054**  
 € 279,600

 12 pcs.  
 COD. 66006050

 COD. **66006059**  
 € 538,800

 12 pcs.  
 COD. 66006055

 COD. **66006064**  
 € 328,800

 12 pcs.  
 COD. 66006060



# 1.2 LINEE ESSENTIAL

ESSENTIAL LINES  
LIGNES ESSENTIAL  
LÍNEAS ESSENTIAL

66006

**MYBIT14**

ESSENTIAL CON CRICCHETTO

ASSORTIMENTO 14 PCS. - INSERTI + PORTAINSERI E CRICCHETTO  
14 PCS. SET - BITS + BIT HOLDER AND RATCHET  
JEU 14 PCS. - EMBOUTS + PORTE-EMBOUTS ET CLIQUET  
JUEGO 14 PCS. - PUNTAS + PORTA PUNTAS Y CARRACA

**NEW!**



14  
pcs.

COD. **66006500**

€ 27,900

61043			61069		
PH1 1pc.	PH2 1pc.	PH3 1pc.	PZ1 1pc.	PZ2 1pc.	PZ3 1pc.

61021			61094		
4,5x0,6 1pc.	5,5x0,8 1pc.	6,5x1,2 1pc.	TX25 1pc.	TX30 1pc.	TX40 1pc.



100 X 170 mm



INCLUSO / INCLUDED  
INCLUDE / INCLUIDO

COD. 62013005



COD. 64221030



66006

ASSORTIMENTI INSERTI  
1/4" COLOUR

ASSORTIMENTO 15 PCS. INSERTI COLOUR CON PORTAINSERI MAGNETICO RAPIDO  
15 PCS. COLOUR BIT-SET WITH QUICK RELEASE MAGNETIC BIT-HOLDER  
JEU 15 PIECES EMBOUTS COLOUR ET PORTE-EMBOUTS MAGNETIQUE RAPIDE  
JUEGO DE 15 PIEZAS PUNTAS COLOUR Y PORTA PUNTAS MAGNETICO RAPIDO

**NEW!**

15  
pcs.

COD. **66006006**

€ 13,000



PH1		PH2		PZ1		PZ2		TX10		TX15		TX20		TX30		
PH1 1pc.	PH2 1pc.	PH1 1pc.	PH2 1pc.	PZ1 1pc.	PZ2 1pc.	TX10 1pc.	TX15 1pc.	TX20 1pc.	TX30 1pc.	TX10 1pc.	TX15 1pc.	TX20 1pc.	TX30 1pc.	TX10 1pc.	TX15 1pc.	TX30 1pc.

4,0x0,5			5,0x0,8			6,0x1,2			3			4			5		
4,0x0,5 1pc.	5,0x0,8 1pc.	6,0x1,2 1pc.	3 1pc.	4 1pc.	5 1pc.	3 1pc.	4 1pc.	5 1pc.	3 1pc.	4 1pc.	5 1pc.	3 1pc.	4 1pc.	5 1pc.	3 1pc.	4 1pc.	5 1pc.



75 X 145 mm



**66009**

## ASSORTIMENTI INSERTI 1/4" + PORTAINSERTE SGANCIO RAPIDO

ASSORTIMENTO 32 PCS. INSERTI CON PORTAINSERTE A SGANCIO RAPIDO  
32 PCS. BITS AND QUICK RELEASE BIT HOLDER SET  
JEU 32 PIÈCES EMOUBS ET PORTE EMOUBS RAPIDE  
JUEGO DE 32 PIEZAS PUNTAS Y PORTA PUNTAS RAPIDO

COD. **66009005**

€ 19,600



32  
pcs.

PH1	PH2	PH3	PZ1	PZ2	PZ3
2pcs.	3pcs.	1pc.	2pcs.	3pcs.	1pc.

3,0x0,5	4,5x0,6	5,5x0,8	6,5x1,2	2	2,5	3	4	5	6
1pc.	1pc.	1pc.	1pc.	1pc.	1pc.	1pc.	1pc.	1pc.	1pc.

TXH09	TXH10	TXH15	TXH20	TXH25	TXH27	TXH30	TXH40
1pc.	1pc.	1pc.	1pc.	1pc.	1pc.	1pc.	1pc.

INCLUSO / INCLUDED  
INCLUDE / INCLUIDO



**66009**

## DISPLAY 6 PCS.

ESPOSITORE DA BANCO 6 ASSORTIMENTI D'INSERTI  
6 PCS. BITS SETS COUNTER DISPLAY  
PRESENTOIR POUR 6 JEU D'EMOUBS  
MOSTRADOR PARA 6 JUEGOS DE PUNTAS

COD. **66009009**

€ 118,000

6  
pcs.



6 pcs.  
COD. 66009005



# 1.2 LINEE ESSENTIAL

ESSENTIAL LINES  
LIGNES ESSENTIAL  
LÍNEAS ESSENTIAL

**66009**

## ASSORTIMENTI INSERTI COLOUR 1/4" + PORTAININSERTI SGANCIO RAPIDO

ASSORTIMENTO 32 PCS. INSERTI CON PORTAININSERTI A SGANCIO RAPIDO  
32 PCS. BITS AND QUICK RELEASE BIT HOLDER SET  
JEU 32 PIÈCES EMBOUTS ET PORTE EMBOUTS RAPIDE  
JUEGO DE 32 PIEZAS PUNTAS Y PORTA PUNTAS RAPIDO

COD. **66009015**

€ 22,700



32  
pcs.

COLOUR RING



PH1	PH2	PH3	PZ1	PZ2	PZ3	1,3x0,5	4,5x0,6	5,5x0,8	6,5x1,2
1pc.	2pcs.	1pc.	1pc.	2pcs.	1pc.	1pc.	1pc.	2pcs.	1pc.

3	4	5	6	TX10	TX15	TX20	TX25	TX27	TX30	TX40
1pc.	1pc.	1pc.	1pc.	1pc.	1pc.	1pc.	1pc.	1pc.	1pc.	1pc.

TXH10	TXH15	TXH20	TXH25	TXH27	TXH30	TXH40
1pc.	1pc.	1pc.	1pc.	1pc.	1pc.	1pc.

INCLUSO / INCLUDED  
INCLUDE / INCLUIDO

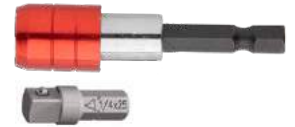

**66009**

## DISPLAY 6 PCS.

ESPOSITORE DA BANCO 6 ASSORTIMENTI D'INSERTI  
6 PCS. BITS SETS COUNTER DISPLAY  
PRESENTOIR POUR 6 JEU D'EMBOUTS  
MOSTRADOR PARA 6 JUEGOS DE PUNTAS

COD. **66009019**

€ 132,000

6  
pcs.

COLOUR RING



6 pcs.  
COD. 66009015







**66012** ASSORTIMENTI INSERTI E BUSSOLE 1/4"  
COLOUR + GIRAVITE A CRICCHETTO











ASSORTIMENTO 26 PCS. INSERTI, BUSSOLE ED ACCESSORI  
26 PCS. BITS, SOCKETS AND ACCESSORIES  
JEU 26 PIÈCES EMBOUTS, DOUILLES ET ACCESSOIRES  
JUEGO DE 26 PIEZAS PUNTAS, VASOS Y ACCESORIOS

1.2



26  
pcs.

COD. **66012006**  
€ 17,900

 				 				
PH1 1pc.	PH2 2pcs.	PH3 1pc.		PZ1 1pc.	PZ2 2pcs.	PZ3 1pc.		
 				 				
1,3x0,5 1pc.	4,5x0,6 1pc.	5,5x0,8 1pc.	6,5x1,2 1pc.	TX10 1pc.	TX15 1pc.	TX20 1pc.	TX25 1pc.	TX30 1pc.
								
5 1pc.	6 1pc.	7 1pc.	8 1pc.	9 1pc.	10 1pc.			

COLOUR RING



INCLUSO / INCLUDED  
INCLUDE / INCLUIDO







REVERSIBILE





# 1.2 LINEE ESSENTIAL

ESSENTIAL LINES  
LIGNES ESSENTIAL  
LÍNEAS ESSENTIAL

**66010**

ASSORTIMENTI ESSENTIAL

ASSORTIMENTO 31 PCS. - INSERTI + PORTAINSERTI  
31 PCS. SET - BITS + BIT-HOLDER  
JEU 31 PCS. - EMBOUTS + PORTE-EMBOUTS  
JUEGO DE 31 PCS. - PUNTAS + PORTA PUNTAS



31 pcs.



80 X 115 X 30 mm

COD. **66010005**

€ 29,900

61043



PH1 2pcs.	PH2 4pcs.	PH3 1pc.
--------------	--------------	-------------

61069



PZ1 2pcs.	PZ2 3pcs.	PZ3 1pc.
--------------	--------------	-------------

61021



0,5x3,0 1pc.	0,6x4,0 1pc.	0,8x5,5 1pc.	1,0x6,0 1pc.	1,2x8,0 1pc.
-----------------	-----------------	-----------------	-----------------	-----------------

61001



2,5 1pc.	3 1pc.	4 1pc.	5 1pc.	6 1pc.
-------------	-----------	-----------	-----------	-----------

61111

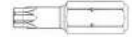

TXH10 1pc.	TXH15 1pc.	TXH20 1pc.	TXH25 1pc.	TXH27 1pc.	TXH30 1pc.	TXH40 1pc.
---------------	---------------	---------------	---------------	---------------	---------------	---------------

INCLUSO / INCLUDED  
INCLUDE / INCLUIDO  
COD. 62013005



IL CONTENITORE È DOTATO INTERNAMENTE DI UNA BASE MAGNETICA CHE EVITA LA FUORIUSCITA ACCIDENTALE DEGLI INSERTI.

THE INSIDE OF THE CONTAINER HAS A MAGNETIC BASE THAT PREVENTS THE BITS FROM ACCIDENTALLY FALLING OUT.

LE CONTENEUR EST ÉQUIPÉ À L'INTÉRIEUR D'UNE BASE MAGNÉTIQUE QUI EMPÊCHE LA CHUTE ACCIDENTELLE DES EMBOUTS.

EL CONTENEDOR ESTÁ PROVISTO INTERNAMENTE DE UNA BASE MAGNÉTICA QUE EVITA LA SALIDA ACCIDENTAL DE LAS PUNTAS.

COD. **66010050**

€ 55,100

61124



06 1pc.	08 1pc.	10 1pc.
------------	------------	------------

61125



1 1pc.	2 1pc.	3 1pc.	4 1pc.
-----------	-----------	-----------	-----------

61122



4 1pc.	6 1pc.	8 1pc.	10 1pc.
-----------	-----------	-----------	------------

61132



4 1pc.	5 1pc.	6 1pc.	8 1pc.	10 1pc.
-----------	-----------	-----------	-----------	------------

61111

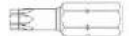

TXH10 1pc.	TXH15 1pc.	TXH20 2pcs.	TXH25 2pcs.	TXH27 1pc.	TXH30 1pc.	TXH40 1pc.
---------------	---------------	----------------	----------------	---------------	---------------	---------------

61121



15 1pc.	20 1pc.	25 1pc.	30 1pc.	40 1pc.
------------	------------	------------	------------	------------



# 66014 ASSORTIMENTI INSERTI 1/4" COLOUR

**NEW!**



42  
pcs.



95 X 130 mm

ASSORTIMENTO 42 PCS. INSERTI COLOUR CON PORTAININSERTI MAGNETICO RAPIDO  
42 PCS. COLOUR BIT-SET WITH QUICK RELEASE MAGNETIC BIT-HOLDER  
JEU 42 PIÈCES EMBOUTS COLOUR ET PORTE-EMBOUTS MAGNETIQUE RAPIDE  
JUEGO DE 42 PIEZAS PUNTAS COLOUR Y PORTA PUNTAS MAGNETICO RAPIDO

COD. **66014004**  
€ 22,500

PH1 3pcs.	PH2 3pcs.	PH3 3pcs.	PZ1 2pcs.	PZ2 2pcs.	PZ3 2pcs.

4,0x0,5 2pcs.	5,0x0,8 1pc.	6,0x1,2 1pc.	3 1pc.	4 1pc.	5 1pc.

TX10 1pc.	TX15 1pc.	TX20 1pc.	TX25 1pc.	TX27 1pc.	TX30 1pc.	TX40 1pc.

TXH10 1pc.	TXH15 1pc.	TXH20 1pc.	TXH25 1pc.	TXH27 1pc.	TXH30 1pc.	TXH40 1pc.

70mm	70mm	70mm	70mm
PH2 1pc.	PZ2 1pc.	TX20 1pc.	1 x 6 1pc.

INCLUSO / INCLUDED  
INCLUSE / INCLUIDO

COD. 62019010

COD. 62100005

1.2



# 1.2 LINEE ESSENTIAL

ESSENTIAL LINES  
LIGNES ESSENTIAL  
LÍNEAS ESSENTIAL

**66014**

**ASSORTIMENTI INSERTI 1/4"  
COLOUR**

ASSORTIMENTO 71 PCS. INSERTI COLOUR CON PORTAININSERTI MAGNETICO RAPIDO  
71 PCS. COLOUR BIT-SET WITH QUICK RELEASE MAGNETIC BIT-HOLDER  
JEU 71 PIÈCES EMBOUTS COLOUR ET PORTE-EMBOUTS MAGNETIQUE RAPIDE  
JUEGO DE 71 PIEZAS PUNTAS COLOUR Y PORTA PUNTAS MAGNETICO RAPIDO

**NEW!**



71  
pcs.



120 X 160 mm

COD. **66014006**

€ 33,800

PH1 3pcs.	PH2 6pcs.	PH3 3pcs.	PZ1 3pcs.	PZ2 6pcs.	PZ3 3pcs.			
4,0x0,6 3pcs.	6,0x1,2 3pcs.	4 3pcs.	5 3pcs.	6 3pcs.				
TX10 3pcs.	TX15 2pcs.	TX20 2pcs.	TX25 2pcs.	TX27 2pcs.	TX30 2pcs.	TX40 2pcs.		
TXH10 1pc.	TXH15 1pc.	TXH20 1pc.	TXH25 1pc.	TXH30 1pc.	TXH40 1pc.			
PH1 1pc.	PH2 1pc.	PH3 1pc.	PZ1 1pc.	PZ2 1pc.	TX25 1pc.	TX30 1pc.	0,5x4 1pc.	1x6 1pc.

INCLUSO / INCLUDED  
INCLUDE / INCLUIDO

COD. 62019010



COD. 62013005





# 66014 ASSORTIMENTI COMPLETI INSERTI 1/4"

ASSORTIMENTO 100 PCS. INSERTI ED ACCESSORI  
 100 PCS. BITS AND ACCESSORIES  
 JEU 100 PIÈCES EMBOUTS ET ACCESSOIRES  
 JUEGO DE 100 PIEZAS PUNTAS Y ACCESORIOS



100 pcs.

COD. **66014010**  
 € 16,000

+				+			
PH0	PH1	PH2	PH3	PZ0	PZ1	PZ2	PZ3
1pc.	1pc.	5pcs.	1pc.	1pc.	1pc.	5pcs.	1pc.

+								
TX08	TX10	TX15	TX20	TX25	TX27	TX30	TX40	TX45
1pc.	1pc.	1pc.	1pc.	1pc.	1pc.	1pc.	1pc.	1pc.

+								
TXH08	TXH10	TXH15	TXH20	TXH25	TXH27	TXH30	TXH35	TXH40
1pc.	1pc.	1pc.	1pc.	1pc.	1pc.	1pc.	1pc.	1pc.

61001									
1,5	2	2,5	3	4	5	5,5	6	8	
1pc.	1pc.	1pc.	1pc.	1pc.	1pc.	1pc.	1pc.	1pc.	

61001										
1/16"	5/64"	3/32"	7/64"	1/8"	9/64"	5/32"	3/16"	7/32"	1/4"	
1pc.	1pc.	1pc.	1pc.	1pc.	1pc.	1pc.	1pc.	1pc.	1pc.	

61001					
2	2,5	3	4	5	6
1pc.	1pc.	1pc.	1pc.	1pc.	1pc.

61001					
5/64"	3/32"	7/64"	1/8"	9/64"	5/32"
1pc.	1pc.	1pc.	1pc.	1pc.	1pc.

-									
3,0x0,5	4,0x0,5	4,5x0,6	5,0x0,8	5,5x0,8	6,0x1,0	6,5x1,2	7,0x1,2	8,0x1,6	
1pc.	1pc.	1pc.	1pc.	1pc.	1pc.	1pc.	1pc.	1pc.	

+			+				+		
1	2	3	4	6	8	10	5	6	8
1pc.	1pc.	1pc.	1pc.	1pc.	1pc.	1pc.	1pc.	1pc.	1pc.

+			+				+			
6	8	10	1	2	3	4	0	1	2	3
1pc.	1pc.	1pc.	1pc.	1pc.	1pc.	1pc.	1pc.	1pc.	1pc.	1pc.





# 1.2 LINEE ESSENTIAL

ESSENTIAL LINES  
LIGNES ESSENTIAL  
LÍNEAS ESSENTIAL

**66014**

**ASSORTIMENTI INSERTI E CHIAVI 1/4"  
+ GIRAVITE**

ASSORTIMENTO 138 PCS. INSERTI, CHIAVI ED ACCESSORI  
138 PCS. BITS, NUT SETTERS AND ACCESSORIES  
JEU 138 PIÈCES EMBOUTS, DOUILLES ET ACCESSOIRES  
JUEGO DE 138 PIEZAS PUNTAS, LLAVES Y ACCESORIOS

COD. **66014015**

€ 27,900



138  
pcs.

+			+		
PH1	PH2	PH3	PZ1	PZ2	PZ3
3pcs.	3pcs.	3pcs.	2pcs.	2pcs.	2pcs.

+	2pcs. PH1 - 2pcs. PH2 - 2pcs. PH3
+	2pcs. PZ1 - 2pcs. PZ2 - 2pcs. PZ3
+	2pcs. TX08 - 2pcs. TX10 - 2pcs. TX15 - 5pcs. TX20 - 6pcs. TX25 - 3pcs. TX27 - 4pcs. TX30 - 4pcs. TX40 -
+	2pcs. TXH08 - 2pcs. TXH10 - 2pcs. TXH15 - 2pcs. TXH20 - 2pcs. TXH25 - 2pcs. TXH27 - 2pcs. TXH30 - 2pcs. TXH40
+	1pc. 10 - 2pcs. 15 - 2pcs. 20 - 3pcs. 25 - 2pcs. 27 - 3pcs. 30 - 2pcs. 40
○	1pc. 3 - 1pc. 4 - 1pc. 5 - 1pc. 6 - 1pc. 8
○	1pc. 3 - 1pc. 4 - 1pc. 5
○	1pc. 4,0x0,5 - 1pc. 4,0x0,6 - 1pc. 5,5x0,8 - 1pc. 6,0x1,0 - 1pc. 6,5x1,2 - 1pc. 8,0x1,6
○	1pc. 1 - 1pc. 2 - 1pc. 3
○	1pc. 4 - 1pc. 6 - 1pc. 8 - 1pc. 10
○	1pc. 5 - 1pc. 6 - 1pc. 8
+	1pc. 6 - 1pc. 8 - 1pc. 10
○	1pc. 1 - 1pc. 2 - 1pc. 3 - 1pc. 4
○	1pc. 1 - 1pc. 2
+	1pc. PH1 - 1pc. PH2 - 1pc. PH3
+	1pc. PZ1 - 1pc. PZ2 - 1pc. PZ3
+	1pc. TX10 - 1pc. TX15 - 1pc. TX20 - 1pc. TX25 - 1pc. TX27 - 1pc. TX30 - 1pc. TX40
+	1pc. 4,0x0,5 - 1pc. 5,5x0,8 - 1pc. 6,5x1,2
○	1pc. 3 - 1pc. 6
+	1pc. 4 - 1pc. 5 - 1pc. 6 - 1pc. 7 - 1pc. 8 - 1pc. 9 - 1pc. 10 - 1pc. 11 - 1pc. 12 - 1pc. 13

portainseri - bit holder



adattatore 1/4"E - 1/4"E adapter



adattatore 1/4"C - 1/4"C adapter



25mm



chiave per tasselli a occhio  
eye screw fixing key



200mm





# 66001 MULTI BIT ESPOSITORE INSERTI

ESPOSITORE DA BANCO CON 25 SCOMPARTI  
 COUNTER DISPLAY WITH 25 COMPARTMENTS  
 PRÉSENTOIR DE COMPTOIR À 25 LOGEMENTS  
 MOSTRADOR DE EXPOSICIÓN DE 25 ALOJAMIENTOS

410 pcs.



445 X 465 X 210 mm

STRUTTURA IN POLIPROPILENE ALVEOLARE AUTOPORTANTE, 25 SCOMPARTI.  
 SELF-SUPPORTING POLYPROPYLENE HONEYCOMB STRUCTURE, 25 COMPARTMENTS.  
 STRUCTURE EN POLYPROPYLÈNE ALVÉOLAIRE AUTOPORTANTE, 25 LOGEMENTS.  
 ESTRUCTURA DE POLIPROPILENO ALVEOLAR AUTOSUSTENTADA, 25 ALOJAMIENTOS.

COD. **66001300**  
 € 349,000

61043 PH1 20pcs.   PH2 50pcs.   PH3 20pcs.			61069 PZ1 20pcs.   PZ2 50pcs.   PZ3 20pcs.		
61094 TX10 10pcs.   TX15 10pcs.   TX20 10pcs.   TX25 20pcs.   TX30 20pcs.   TX40 20pcs.					
61001 2 10pcs.   2,5 10pcs.   3 10pcs.   4 10pcs.   5 10pcs.   6 10pcs.					
61021 0,5x3,0 10pcs.		0,6x4,5 10pcs.		1,0x5,5 10pcs.	
63004 8x45 10pcs.		10x45 10pcs.		62015010 1/4"x1/4"x60mm 20pcs.	



# 1.2 LINEE ESSENTIAL

ESSENTIAL LINES  
LIGNES ESSENTIAL  
LÍNEAS ESSENTIAL

66001

## MULTISTORE ESPOSITORE A CASSETTI

STRUTTURA ESPOSITORE PER STORE6 E STORE9  
DISPLAY STRUCTURE FOR STORE6 AND STORE9  
STRUCTURE PRÉSENTOIR POUR STORE6 ET STORE9  
MOSTRADOR DE EXPOSICIÓN PARA STORE6 Y STORE9



COD. 66001005VC

Struttura metallica vuota + top  
Empty metal structure + top  
Structure en métal vide + Top  
Estructura metálica vacía + top

610 X 600 X 150 mm

STRUTTURA METALLICA DA BANCO E APPENDIBILE. CASSETTIERE BASCULANTI SOVRAPPONIBILI CHE SI AGGANCIANO ALLA STRUTTURA. LA MADIA PUÒ OSPITARE FINO A 6 FILE DI CASSETTIERE (4 SE DEL TIPO A 6 CASSETTI) COUNTERTOP AND HANGABLE METAL STRUCTURE. UP-AND-OVER DRAWERS THAT CAN BE HOOKED ONTO THE STRUCTURE. THE DISPLAY CABINET CAN HOLD UP TO 6 ROWS OF DRAWERS (4 FOR THE STORE6 CABINET)

MEUBLES À TIROIRS SUPERPOSABLES QUI S'ACCROCHENT À LA STRUCTURE. LE MEUBLE PEUT ACCUEILLIR JUSQU'À 6 RANGÉES DE MEUBLES À TIROIRS (4 DE TYPE STORE6).

ESTRUCTURA METÁLICA PARA MOSTRADOR que se puede COLGAR. CAJONES BASCULANTES APILABLES QUE SE ENGANCHAN A LA ESTRUCTURA. EL APARADOR PUEDE ALOJAR HASTA 6 FILAS DE CAJONES (4 SI ES DEL TIPO STORE6)



Personalizza il MULTISTORE scegliendo tra le versioni seguenti.  
Customise your MULTISTORE by choosing from the following versions.  
Personnaliser le MULTISTORE en choisissant parmi les versions suivantes.  
Personaliza el MULTISTORE escogiendo entre las siguientes versiones.

1

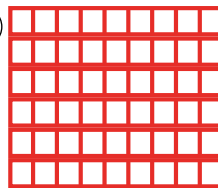

6 x **STORE9**

2

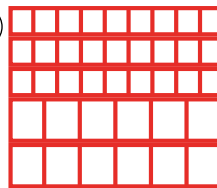

3 x **STORE9** + 2 x **STORE6**

3

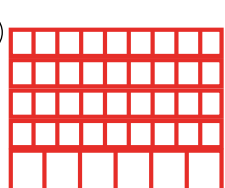

4 x **STORE9** + 1 x **STORE6**

### STORE9 PREMIUM

p. 35	MAG-Bit+™	66001080	€ 219,000
p. 47	COLOUR+	66001085	€ 132,000
p. 60	PULSAR®	66001055	€ 167,000
p. 60	PULSAR®	66001056	€ 192,000
p. 73	TORSION®	66001060	€ 138,000
p. 73	TORSION®	66001061	€ 164,000
p. 85	TORSION+	66001065	€ 175,000
p. 85	TORSION+	66001066	€ 201,000
p. 97	HDC	66001070	€ 259,000
p. 97	HDC	66001071	€ 271,000
p. 109	TITANIUM	66001050	€ 208,000
p. 109	TITANIUM	66001051	€ 206,000
p. 120	INX	66001075	€ 214,000
p. 120	INX	66001076	€ 198,000

### STORE9 ESSENTIAL

p. 185	ESSENTIAL	66001020	€ 145,000
p. 185	ESSENTIAL	66001025	€ 175,000
p. 185	ESSENTIAL	66001030	€ 185,000
p. 185	ESSENTIAL	66001035	€ 154,000
p. 185	ESSENTIAL	66001040	€ 166,000
p. 185	ESSENTIAL	66001045	€ 242,000

### STORE6 ESSENTIAL

p. 195	ESSENTIAL	66001105	€ 111,000
p. 209	ESSENTIAL	66001120	€ 239,000

### STORE6

p. 322		66001110	€ 173,000
p. 331		66001115	€ 272,000





**66001**

**STORE 9**

**ASSORTIMENTI ESSENTIAL**

CASSETTIERA CON 9 SCOMPARTI PER ESPOSITORE MULTISTORE  
 DRAWERS WITH 9 COMPARTMENTS FOR MULTISTORE DISPLAY  
 TIROIRS AVEC 9 COMPARTIMENTS POUR PRESENTOIR MULTISTORE  
 9 CAJONES PARA MOSTRADOR DE EXPOSICIÓN TIPO MULTISTORE



600 X 90 X 65 mm

1.2



**200 pcs.** COD. **66001025** € 175,000

61001			61021					
2,5	3	4	5	6	0,5x3,0	0,6x4,0	1,0x5,5	1,2x6,5
10pcs.	20pcs.	20pcs.	30pcs.	30pcs.	10pcs.	20pcs.	30pcs.	30pcs.

**170 pcs.** COD. **66001035** € 154,000

61094					61111			
TX15	TX20	TX25	TX30	TX40	TXH15	TXH20	TXH25	TXH30
20pcs.	20pcs.	30pcs.	30pcs.	30pcs.	10pcs.	10pcs.	10pcs.	10pcs.

**220 pcs.** COD. **66001020** € 145,000

61043				61069			
PH0	PH1	PH2	PH3	PZ0	PZ1	PZ2	PZ3
10pcs.	25pcs.	50pcs.	20pcs.	10pcs.	25pcs.	50pcs.	20pcs.

**180 pcs.** COD. **66001030** € 185,000

61094							
TX09	TX10	TX15	TX20	TX25	TX27	TX30	TX40
10pcs.	10pcs.	20pcs.	30pcs.	30pcs.	10pcs.	30pcs.	30pcs.

62015010

1/4"x1/4"x60mm  
10pcs.

62016010

1/4"x1/4"x60mm  
10pcs.

**240 pcs.** COD. **66001040** € 166,000

61048			61073		
PH1	PH2	PH3	PZ1	PZ2	PZ3
25pcs.	50pcs.	20pcs.	25pcs.	50pcs.	20pcs.

**150 pcs.** COD. **66001045** € 242,000

61051			61076		
PH1	PH2	PH3	PZ1	PZ2	PZ3
10pcs.	30pcs.	10pcs.	10pcs.	30pcs.	10pcs.

61056	61082
PH2	PZ2
20pcs.	20pcs.

61097		
TX25	TX30	TX40
10pcs.	20pcs.	20pcs.

62015010

1/4"x1/4"x60mm  
10pcs.



# 1.2 LINEE ESSENTIAL

ESSENTIAL LINES  
LIGNES ESSENTIAL  
LÍNEAS ESSENTIAL

66001

**MULTI**BOX

ESPOSITORE MINIBOX

ESPOSITORE DA BANCO IN FILO METALLICO PER MINIBOX  
METAL WIRE COUNTER DISPLAY FOR MINIBOX  
PRÉSENTOIR DE COMPTOIR EN FIL MÉTALLIQUE POUR MINIBOX  
MOSTRADOR DE EXPOSICIÓN DE ALAMBRE PARA MINIBOX



560  
pcs.

COD. **66001500**  
€ 481,000

			L mm	COD.	box
10 pcs.		<b>PH0</b>	25	61043005010	4
10 pcs.		<b>PH1</b>	25	61048005010	4
10 pcs.		<b>PH2</b>	25	61048015010	4
10 pcs.		<b>PH3</b>	25	61048025010	4
10 pcs.		<b>PZ1</b>	25	61073005010	4
10 pcs.		<b>PZ2</b>	25	61073015010	4
10 pcs.		<b>PZ3</b>	25	61073025010	4
10 pcs.		<b>TX15</b>	25	61094030010	3
10 pcs.		<b>TX20</b>	25	61094035010	3
10 pcs.		<b>TX25</b>	25	61094040010	3
10 pcs.		<b>TX30</b>	25	61094050010	3
10 pcs.		<b>TX40</b>	25	61094055010	3
10 pcs.		<b>0,6x4,5</b>	25	61021020010	3
10 pcs.		<b>1,2x6,5</b>	25	61021045010	3
5 pcs.		<b>PH1</b>	50	61056030005	2
5 pcs.		<b>PH2</b>	50	61056035005	2
5 pcs.		<b>PH3</b>	50	61056040005	2
5 pcs.		<b>PZ1</b>	50	61082030005	2
5 pcs.		<b>PZ2</b>	50	61082035005	2
5 pcs.		<b>PZ3</b>	50	61082040005	2
1 pc.				62015010001	6
1 pc.				62029005	4



370 X 545 X 220 mm

STRUTTURA IN FILO METALLICO DA BANCO ED APPENDIBILE ADATTA AD ACCOGLIERE 20 MISURE DIVERSE DI INSERTI CONFEZIONATI IN MINIBOX E DUE ARTICOLI ACCESSORI.

COUNTERTOP OR WALL-MOUNTED METAL WIRE STRUCTURE, SUITABLE FOR HOLDING BITS IN 20 DIFFERENT SIZES, MINIBOX PACKED AND TWO ACCESSORIES.

STRUCTURE EN FIL MÉTALLIQUE DE COMPTOIR ET À SUSPENDRE, ADAPTÉE POUR 20 TAILLES DIFFÉRENTES D'EMBOUTS EMBALLÉS DANS UNE MINI-BOÎTE ET DEUX ARTICLES ACCESSOIRES.

ESTRUCTURA DE HILO METÁLICO PARA MOSTRADOR QUE SE PUEDE COLGAR APTA PARA ALOJAR 20 DIFERENTES MEDIDAS DE PUNTAS PUESTOS EN MINICAJAS MÁS DOS ARTÍCULOS DE ACCESORIOS.

**66001**
**MULTIBOX**  
 ESPOSITORE MINIBOX

 ESPOSITORE DA BANCO IN FILO METALLICO PER MINIBOX  
 METAL WIRE COUNTER DISPLAY FOR MINIBOX  
 PRÉSENTOIR DE COMPTOIR EN FIL MÉTALLIQUE POUR MINIBOX  
 MOSTRADOR DE EXPOSICIÓN DE ALAMBRE PARA MINIBOX

**678**  
 pcs.
COD. **66001501****€ 576,000**

			L mm	COD.	box	
10 pcs.		<b>PH0</b>	25	61043005010	4	
10 pcs.		<b>PH1</b>	25	61043010010	4	
10 pcs.		<b>PH2</b>	25	61043020010	4	
10 pcs.		<b>PH3</b>	25	61043030010	4	
10 pcs.		<b>PZ1</b>	25	61069010010	4	
10 pcs.		<b>PZ2</b>	25	61069020010	4	
10 pcs.		<b>PZ3</b>	25	61069030010	4	
10 pcs.		<b>TX15</b>	25	61094030010	3	
10 pcs.		<b>TX20</b>	25	61094035010	3	
10 pcs.		<b>TX25</b>	25	61094040010	3	
10 pcs.		<b>TX30</b>	25	61094050010	3	
10 pcs.		<b>TX40</b>	25	61094055010	3	
10 pcs.		<b>0,6x3,5</b>	25	61021010010	3	
10 pcs.		<b>0,6x4,5</b>	25	61021020010	3	
10 pcs.		<b>0,8x5,5</b>	25	61021035010	3	
10 pcs.		<b>1,2x6,5</b>	25	61021045010	3	
10 pcs.		<b>3</b>	25	61001020010	3	
10 pcs.		<b>4</b>	25	61001025010	3	
10 pcs.		<b>5</b>	25	61001030010	3	
10 pcs.		<b>6</b>	25	61001035010	3	
1 pc.					62015010001	4
1 pc.					62029005	4



370 X 545 X 220 mm

STRUTTURA IN FILO METALLICO DA BANCO ED APPENDIBILE ADATTA AD ACCOGLIERE 20 MISURE DIVERSE DI INSERTI CONFEZIONATI IN MINIBOX E DUE ARTICOLI ACCESSORI.

COUNTERTOP OR WALL-MOUNTED METAL WIRE STRUCTURE, SUITABLE FOR HOLDING BITS IN 20 DIFFERENT SIZES, MINIBOX PACKED AND TWO ACCESSORIES.

STRUCTURE EN FIL MÉTALLIQUE DE COMPTOIR ET À SUSPENDRE, ADAPTÉE POUR 20 TAILLES DIFFÉRENTES D'EMBOUTS EMBALLÉS DANS UNE MINI-BOÎTE ET DEUX ARTICLES ACCESSOIRES.

ESTRUCTURA DE HILO METÁLICO PARA MOSTRADOR QUE SE PUEDE COLGAR APTA PARA ALOJAR 20 DIFERENTES MEDIDAS DE PUNTAS PUESTOS EN MINICAJAS MÁS DOS ARTÍCULOS DE ACCESORIOS.





# 1.2 LINEE ESSENTIAL

ESSENTIAL LINES  
LIGNES ESSENTIAL  
LÍNEAS ESSENTIAL

**63002**

## CHIAVI A BUSSOLA NON MAGNETICHE

CHIAVI 1/4"E A BUSSOLA NON MAGNETICHE  
1/4"E NON-MAGNETIC NUT SETTERS  
DOUILLES 1/4 "E NON MAGNÉTIQUES  
LLAVE DE VASO DE 1/4"E DIAMAGNÉTICOS

48/50 HRC

**EASYPACK** | sacchetto PVC con Euro-hole • PVC bags with Euro-hole

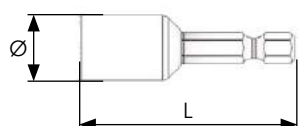

Hex	L mm	Ø mm	PCS.	COD.	€ cad./each
5	45	10	5	63002002	1,620
5,5	45	10	5	63002003	1,620
6	45	11	5	63002004	1,620
7	45	12,5	5	63002005	1,820
	65	12,5	5	63002009	2,250
8	45	12,5	5	63002010	1,820
	65	12,5	5	63002011	2,250
10	45	14,5	5	63002015	2,040
	65	14,5	5	63002016	2,440
11	45	16	5	63002017	2,250
	65	16	5	63002018	2,630
12	45	18	5	63002019	2,330
	65	18	5	63002021	2,950
13	45	18,5	5	63002020	2,440
	65	18,5	5	63002025	3,140
17	50	24	5	63002050	8,990

Hex	Ø mm	L mm	COD.	€ box
7	12,5	45	63002005001	3,160
8	12,5	45	63002010001	3,000
10	14,5	45	63002015001	3,190
13	18,5	45	63002020001	3,550



**SELPACK**  
1 pc.

**63004**

## CHIAVI A BUSSOLA MAGNETICHE

CHIAVI 1/4"E A BUSSOLA MAGNETICHE  
1/4"E MAGNETIC NUT SETTERS  
DOUILLES 1/4 "E MAGNÉTIQUES  
LLAVE DE VASO DE 1/4"E MAGNÉTICOS

48/50 HRC

**EASYPACK** | sacchetto PVC con Euro-hole • PVC bags with Euro-hole

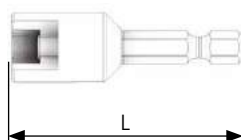

Hex	L mm	Ø mm	PCS.	COD.	€ cad./each
5	45	10	5	63004005	1,920
5,5	45	10	5	63004010	1,920
6	45	11	5	63004015	1,920
7	45	12,5	5	63004020	2,130
	65	12,5	5	63004025	2,550
8	45	12,5	5	63004030	2,130
	65	12,5	5	63004035	2,550
10	45	14,5	5	63004040	2,330
	65	14,5	5	63004045	2,740
11	45	16	5	63004050	2,550
12	45	18	5	63004055	2,630
13	45	18,5	5	63004060	2,840
	65	18,5	5	63004065	3,540
17	50	24	5	63004100	10,100

Hex	Ø mm	L mm	COD.	€ box
5,5	10	45	63004010001	3,260
6	11	45	63004015001	3,260
7	12,5	45	63004020001	3,470
8	12,5	45	63004030001	3,470
10	14,5	45	63004040001	3,670
13	18,5	45	63004060001	4,180
17	50	24	63004100001	11,400



**SELPACK**  
1 pc.

**63006**

## CHIAVI A BUSSOLA MAGNETICHE (POLLICI)

48/50 HRC

CHIAVI 1/4"E A BUSSOLA MAGNETICHE MISURE IN POLLICI  
1/4"E MAGNETIC NUT SETTERS INCHES SIZES  
DOUILLES 1/4 "E MAGNÉTIQUES, DIMENSIONS EN POUCES  
LLAVE DE VASO DE 1/4"E MAGNÉTICOS MEDIDAS EN PULGADAS

EASYPACK | sacchetto PVC con Euro-hole • PVC bags with Euro-hole



Hex	L mm	Ø mm	PCS.	COD.	€ cad./each
1/4"	45	11	5	63006005	3,940
5/16"	45	12,5	5	63006010	4,100
3/8"	45	14	5	63006015	4,370

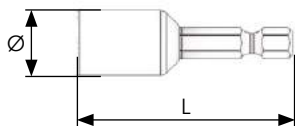

1.2

**63010**

## CHIAVI A BUSSOLA PER VITI INOX

48/50 HRC

CHIAVI 1/4"E A BUSSOLA CON SFERA PER TRATTENERE IL DADO  
1/4"E NUT SETTERS WITH BALL FOR SCREW RETENTION  
DOUILLES 1/4"E AVEC BILLE POUR RETENIR L'ÉCROU  
LLAVE DE VASO DE 1/4"E CON ESFERA PARA RETENER LA TUERCA

EASYPACK | sacchetto PVC con Euro-hole • PVC bags with Euro-hole



Hex	L mm	PCS.	COD.	€ cad./each
6	45	5	63010005	6,160
7	45	5	63010010	6,160
8	45	5	63010015	6,160
10	45	5	63010025	6,700
11	45	5	63010030	6,700
12	45	5	63010035	8,570
13	45	5	63010040	8,570
14	45	5	63010045	8,570

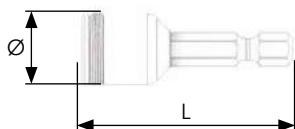

### FOCUS ON



Una sfera che agisce sulla superficie del dado/bullone esercitando il trattamento anche su acciaio inox, ottone o altri metalli non ferrosi.

A ball that acts on the surface of the nut/bolt, exerting retention even on stainless steel, copper or other non-ferrous metals.

Une bille qui agit sur la surface du boulon/écrou en exerçant une rétention même sur l'acier inoxydable, le laiton et les autres métaux non ferreux.

Una esfera que actúa en la superficie de la tuerca/perno ejercitando la retención también sobre acero inoxidable, latón u otros metales no ferrosos.





# 1.2 LINEE ESSENTIAL

ESSENTIAL LINES  
LIGNES ESSENTIAL  
LÍNEAS ESSENTIAL

**63001**

## CHIAVI A BUSSOLA NON MAGNETICHE AD ALTA RESISTENZA

CHIAVI 1/4"E A BUSSOLA NON MAGNETICHE AD ALTA RESISTENZA  
1/4"E NON-MAGNETIC HIGH-RESISTANCE NUT SETTERS  
DOUILLES 1/4"E NON MAGNÉTIQUES HAUTE RÉSTISANCE  
LLAVE DE VASO DE 1/4"E NO MAGNÉTICOS DE ALTA RESISTENCIA

56/58 HRC

**EASYPACK** | sacchetto PVC con Euro-hole • PVC bags with Euro-hole

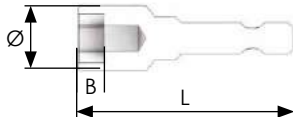

●	L mm	Ø mm	B	PCS.	COD.	€ cad./each
4	50	7,5	2,5	5	63001005	9,240
	75	7,5	2,5	5	63001170	11,700
	100	7,5	2,5	5	63001175	19,600
4,5	50	8	2,5	5	63001010	9,240
	75	8	2,5	5	63001180	11,700
	100	8	2,5	5	63001185	19,600
5	50	9	3	5	63001015	8,570
	75	9	3	5	63001020	11,700
	100	9	3	5	63001025	19,600
5,5	50	9	3,5	5	63001030	8,570
	75	9	3,5	5	63001035	11,700
	100	9	3,5	5	63001040	19,600
6	50	10	4	5	63001045	8,570
	75	10	4	5	63001050	11,700
	100	10	4	5	63001055	19,600
	150	10	4	5	63001220	28,400
7	50	11	4,5	5	63001060	7,370
	75	11	4,5	5	63001065	10,200
	100	11	4,5	5	63001070	12,100
	150	11	4,5	5	63001225	28,400
8	50	13	5,5	5	63001075	7,370
	75	13	5,5	5	63001080	10,200
	100	13	5,5	5	63001085	12,100
	150	13	5,5	5	63001230	28,400

●	L mm	Ø mm	B	PCS.	COD.	€ cad./each
9	50	14	5,5	5	63001090	7,640
	75	14	5,5	5	63001095	10,500
	100	14	5,5	5	63001190	35,400
10	50	15	6,5	5	63001100	7,640
	75	15	6,5	5	63001105	10,500
	100	15	6,5	5	63001110	12,800
	150	15	6,5	5	63001235	29,200
11	50	17	7,5	5	63001115	12,000
	75	17	7,5	5	63001120	14,500
12	100	17	7,5	5	63001195	16,500
	50	18	8,5	5	63001125	12,000
	75	18	8,5	5	63001130	14,500
13	100	18	8,5	5	63001135	16,500
	50	19	9,5	5	63001140	12,000
	75	19	9,5	5	63001145	12,200
14	100	19	9,5	5	63001150	14,500
	50	20	10,5	5	63001155	26,300
	75	20	10,5	5	63001160	30,700
15	100	20	10,5	5	63001200	31,900
	50	24	11,5	5	63001205	48,300
17	50	25	11,5	5	63001165	29,100



### TIPS

Chiavi a bussola ad alta resistenza realizzate in acciaio speciale al cromo-silicio-vanadio, utilizzabili anche con avvitatori ad impulsione. (N.B: La massima forza applicabile non deve superare quelle indicate per l'attacco esagonale 1/4", vedi dati tecnici in coda al catalogo)

High-strength nut setters made of special chrome-silicon-vanadium steel, which can also be used with impact wrenches. (N.B: The maximum forces that can be applied must not exceed those specified for 1/4" hex attachments, see technical data at the end of the catalogue)

Clés à douille haute résistance réalisées en acier spécial au chrome-silicium-vanadium, à utiliser également avec des visseuses à impulsions. N. B. : la force maximale applicable ne doit pas dépasser celles qui sont indiquées pour le raccord hexagonal 1/4". Voir les paramètres techniques à la fin du catalogue.

Vasos de alta resistencia realizadas de acero especial en cromo-silicio-vanadio. También se pueden usar con atornilladores a impulsos. (Nota: El máximo esfuerzo aplicable no tiene que superar el indicado para el empalme hexagonal de 1/4", véase los datos técnicos al final del catálogo)

**63003**

# CHIAVI A BUSSOLA MAGNETICHE AD ALTA RESISTENZA

CHIAVI 1/4"E A BUSSOLA MAGNETICHE AD ALTA RESISTENZA  
 1/4"E MAGNETIC HIGH-RESISTANCE NUT SETTERS  
 DOUILLES 1/4"E MAGNÉTIQUES HAUTE RÉISTANCE  
 LLAVE DE VASO DE 1/4"E MAGNÉTICOS DE ALTA RESISTENCIA

56/58 HRC

EASYPACK | sacchetto PVC con Euro-hole • PVC bags with Euro-hole

1.2

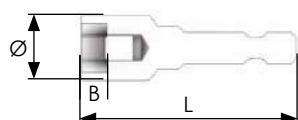

●	L mm	Ø mm	B	PCS.	COD.	€ cad./each
4	50	7,5	1,5	5	63003005	12,000
	75	7,5	1,5	5	63003170	14,400
	100	7,5	1,5	5	63003175	22,300
4,5	50	8	1,5	5	63003010	12,000
	75	8	1,5	5	63003180	14,400
	100	8	1,5	5	63003185	22,300
5	50	9	2	5	63003015	11,300
	75	9	2	5	63003020	14,400
	100	9	2	5	63003025	22,300
5,5	50	9	2	5	63003030	11,300
	75	9	2	5	63003035	14,400
	100	9	2	5	63003040	22,300
6	50	10	2,5	5	63003045	11,300
	75	10	2,5	5	63003050	14,400
	100	10	2,5	5	63003055	22,300
7	50	11	3	5	63003060	11,400
	75	11	3	5	63003065	14,200
	100	11	3	5	63003070	16,100
8	150	11	3	5	63003215	32,500
	50	13	3	5	63003075	11,400
	75	13	3	5	63003080	14,200
8	100	13	3	5	63003085	16,100
	150	13	3	5	63003225	32,500

●	L mm	Ø mm	B	PCS.	COD.	€ cad./each
9	50	14	4	5	63003090	11,700
	75	14	4	5	63003095	14,500
	100	14	4	5	63003190	37,900
10	50	15	4	5	63003100	11,700
	75	15	4	5	63003105	14,500
	100	15	4	5	63003110	16,800
11	150	15	4	5	63003235	33,300
	50	17	5	5	63003115	16,000
	75	17	5	5	63003120	18,500
12	100	17	5	5	63003195	20,500
	50	18	6	5	63003125	16,000
	75	18	6	5	63003130	18,500
13	100	18	6	5	63003135	20,500
	50	19	6	5	63003140	16,000
	75	19	6	5	63003145	16,300
14	100	19	6	5	63003150	18,500
	50	20	6	5	63003155	30,300
	75	20	6	5	63003160	34,700
17	100	20	6	5	63003200	35,900
	50	25	7	5	63003165	33,100

**FOCUS ON**

Su richiesta possiamo realizzare chiavi a bussola fino a lunghezza 390 mm, con cave differenti (es. poligonale, TORX® femmina, quadro). Siamo inoltre in grado di tarare la durezza finale in base alle specifiche necessità.

On request, we are also able to manufacture nut setters up to 390 mm long, with different slots (e.g. polygonal, TORX® female, square). We are also able to calibrate the final hardness according to specific needs.

Sur demande, nous pouvons réaliser des clés à douilles jusqu'à 390 mm de longueur avec des creux différents (par exemple polygonale, TORX® femelle, carré). Nous pouvons aussi calibrer la dureté finale selon les besoins spécifiques.

Bajo petición podemos realizar llaves de vaso de hasta una longitud de 390 mm, con diferentes ranuras (por ejemplo poligonal, TORX® hembra, cuadrada). También podemos calibrar la dureza final según las específicas necesidades.



# 1.2 LINEE ESSENTIAL

ESSENTIAL LINES  
LIGNES ESSENTIAL  
LÍNEAS ESSENTIAL

**63005**

## CHIAVI A BUSSOLA MAGNETE RETRATTILE

CHIAVI 1/4"E A BUSSOLA ALTA RESISTENZA CON MAGNETE RETRATTILE  
1/4"E NUT SETTERS WITH SPRING LOADED MAGNET  
DOUILLES 1/4"E HAUTE RÉSISTANCE AVEC AIMANT RÉTRACTABLE  
LLAVE DE VASO DE 1/4"E DE ALTA RESISTENCIA CON IMÁN RETRACTIL

56/58 HRC

**EASYPACK** | sacchetto PVC con Euro-hole • PVC bags with Euro-hole



●	L mm	Ø mm	PCS.	COD.	€ cad./each
7	75	11	1	63005005	41,000
8	75	13	1	63005010	41,000
10	75	15	1	63005015	43,300



### FOCUS ON

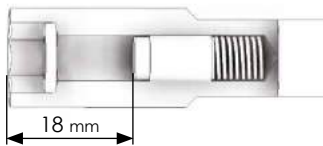

Il sistema magnete retrattile permette sia il trattenimento magnetico del dado che l'ingresso libero della vite nella chiave per una profondità massima di 18mm.

The retractable magnet system allows both magnetic retention of the nut and the free entry of the screw into the nut setter for a maximum depth of 18mm.

Le système à aimant rétractable permet la rétention magnétique tant de l'écrou que l'entrée libre de la vis dans la clé sur une profondeur maximale de 18 mm.

El sistema con imán retractil permite ya sea la retención magnética de la tuerca que la entrada libre del tornillo en la llave por una profundidad máxima de 18mm.

**63012**

## CHIAVI A BUSSOLA SCARICO PROFONDO

CHIAVI 1/4"E A BUSSOLA CON SCARICO PROFONDO  
1/4"E DEEP HOLE NUT SETTERS  
DOUILLES 1/4 "E PROFONDE  
LLAVE DE VASO DE 1/4"E CON DESCARGA PROFUNDA

52/54 HRC

**EASYPACK** | sacchetto PVC con Euro-hole • PVC bags with Euro-hole



●	L mm	dxℓ mm	Ø mm	PCS.	COD.	€ cad./each
7	100	6x50	11	5	63012005	13,200
	150	6x100	11	5	63012010	33,300
8	100	7x50	13	5	63012015	13,200
	150	7x100	13	5	63012020	33,300
10	100	8x50	15	5	63012025	13,400
	150	8x100	15	5	63012030	34,900
13	100	10x50	19	5	63012035	16,300
	150	10x100	19	5	63012040	37,500

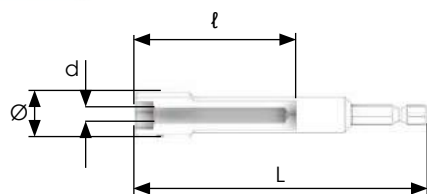

### FOCUS ON



Ideali quando il gambo filettato sporge molto dal dado o per l'avvitatura di prigionieri.

Ideal when the threaded shaft protrudes significantly from the nut or for screwing captive screws.

Idéales lorsque la tige filetée dépasse de l'écrou ou pour le vissage des goujons.

Idéales cuando el vástago roscado sobresale mucho de la tuerca o para el atornillado de los prisioneros.





# 63011 CHIAVI A BUSSOLA IMPACT MAGNETICHE

CHIAVI 1/4"E A BUSSOLA MAGNETE FLOTTANTE PER AVVITATORI A MASSA BATTENTE  
1/4"E NUT SETTERS WITH FLOATING MAGNET FOR IMPACT WRENCHES  
DOUILLES 1/4"E AVEC AIMANT FLOTTANTE POUR VISSEUSE À CHOCS  
LLAVE DE VASO DE 1/4"E CON IMÁN FLOTANTE PARA ATTORNILLADORES DE IMPACTO

56/58 HRC

**EASYPACK** | sacchetto PVC con Euro-hole • PVC bags with Euro-hole



Ø	L mm	Ø mm	PCS.	COD.	€ cad./each
7	65	11	5	63011010	6,620
8	65	12,5	5	63011015	6,620
10	65	15	5	63011025	7,310
13	65	18,5	5	63011040	8,190

1.2



## FOCUS ON

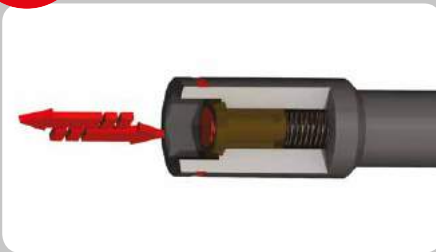

Realizzate in acciaio speciale al cromo-silicio-vanadio hanno una durezza e una resistenza alla torsione molto elevate.

Made of special chrome-silicon-vanadium steel, they are very hard and extremely resistant to twisting.

Fabriquées en acier spécial au chrome-silicium-vanadium, elles offrent une dureté et une résistance à la torsion très élevée.

Realizadas con acero especial al cromo-silicio-vanadio, tienen una dureza y una resistencia a la torsión muy elevadas.

# 63011 DISPLAY DA BANCO CHIAVI A BUSSOLA IMPACT MAGNETICHE

ESPOSITORE 24 PCS. CHIAVI A BUSSOLA MAGNETICHE IMPACT  
24 PCS. MAGNETIC IMPACT NUT SETTERS COUNTER DISPLAY  
PRÉSENTOIR POUR 24 DUILLES MEGNETIQUES IMPACT  
MOSTRADOR PARA 24 PIEZAS VASOS IMPACT MAGNETICOS



24  
pcs.

COD. **63011002**  
€ 195,500

63011



7 6pcs.	8 6pcs.	10 6pcs.	13 6pcs.
------------	------------	-------------	-------------

120 X 40 X 195 mm



# 1.2 LINEE ESSENTIAL

ESSENTIAL LINES  
LIGNES ESSENTIAL  
LÍNEAS ESSENTIAL

**63600**

## ASSORTIMENTI CHIAVI A BUSSOLA NON MAGNETICHE

ASSORTIMENTO 10 PEZZI CHIAVI A BUSSOLA NON MAGNETICHE  
10 PCS. NON-MAGNETIC NUT SETTERS SET  
JEU 10 PIÈCES CLÉS À DOUILLE NON MAGNÉTIQUES  
JUEGO DE 10 LLAVE DE VASO NO MAGNÉTICOS



10  
pcs.

COD. **63600001**

€ 8,300

63002



4	5	5,5	6	7	8	9	10	12	13
2pcs.	1pc.	1pc.	1pc.	1pc.	1pc.	1pc.	1pc.	1pc.	1pc.

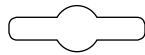

EURO-HOLE

85 X 150 mm

**63600**

## ASSORTIMENTI CHIAVI A BUSSOLA MAGNETICHE

ASSORTIMENTO 6 PEZZI CHIAVI A BUSSOLA MAGNETICHE  
6 PCS. MAGNETIC NUT SETTERS SET  
JEU 6 PIÈCES CLÉS À DOUILLE MAGNÉTIQUES  
JUEGO DE 6 LLAVE DE VASO MAGNÉTICOS



6  
pcs.

COD. **63600005**

€ 7,900

63004



5,5	6	7	8	10	13
1pc.	1pc.	1pc.	1pc.	1pc.	1pc.

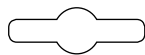

EURO-HOLE

85 X 150 mm

**63600****DISPLAY DA BANCO CHIAVI A BUSSOLA**

ESPOSITORE DA BANCO IN PLEXIGLASS PER 24 PEZZI  
 COUNTER DISPLAY IN PLEXIGLASS FOR 24 PIECES  
 PRÉSENTOIR DE COMPTOIR EN PLEXIGLASS POUR 24 PIÉCES  
 MOSTRADOR DE EXPOSICIÓN IN PLEXIGLASS PARA 24 PIEZAS



120 X 40 X 195 mm

**24  
pcs.**COD. **63600016****€ 75,600**

63004

7  
6pcs.8  
6pcs.10  
6pcs.13  
6pcs.

1.2

**66001****STORE 6  
ASSORTIMENTI ESSENTIAL**

CASSETTIERA CON 6 SCOMPARTI PER ESPOSITORE MULTISTORE  
 DRAWERS WITH 6 COMPARTMENTS FOR MULTISTORE DISPLAY  
 TIROIRS AVEC 6 COMPARTIMENTS POUR PRESENTOIR MULTISTORE  
 6 CAJONES PARA MOSTRADOR DE EXPOSICIÓN TIPO MULTISTORE



600 X 115 X 65 mm

**50  
pcs.**COD. **66001105****€ 111,000**

63004

5,5  
5pcs.7  
10pcs.8  
10pcs.10  
10pcs.13  
10pcs.17  
5pcs.**MULTI STORE**

COD. 66001005VC

PER DETAGLI E COMPOSIZIONE VEDERE P. 184  
 FOR DETAILS AND COMPOSITION SEE P. 184  
 POUR LES DÉTAILS ET LA COMPOSITION VOIR P. 184  
 PARA MÁS DETALLES Y COMPOSICIÓN VÉASE P. 184



*Fino a non molti anni fa esistevano solo due tipi di porta-inserti: quello non magnetico e quello magnetico. Oggi le soluzioni offerte sono molte e scegliere l'accessorio giusto può essere di aiuto a rendere più facile il lavoro. Per questo motivo, la terza sezione del capitolo, dedicata agli accessori per inserti da 1/4", è ampiamente corredata di indicazioni e suggerimenti utili per individuare correttamente l'accessorio più adatto.*

*The market for bit holders offers solutions that are increasingly more specific and that adapt well to the working conditions or workpieces. Having the right accessory will make the job easier and faster. For this reason, the third section of the chapter contains accessories for 1/4" bits together with lots of useful suggestions and tips on how to find the most suitable accessory for every type of application or work environment.*

*Le marché des porte-embouts offre des solutions de plus en plus spécifiques qui s'adaptent aux conditions de travail ou aux matériaux sur lesquels on travaille. Choisir le bon accessoire permet de travailler plus simplement et rapidement. C'est pour cette raison que la troisième section du chapitre 1 dédiée aux accessoires pour les embouts 1/4", est largement illustrée de mises au point et conseils pour choisir correctement l'accessoire le mieux adapté à chaque type d'application ou lieu de travail.*

El mercado de los porta puntas ofrece soluciones cada vez más específicas que se adaptan bien a las condiciones de trabajo o a los materiales sobre los cuales se trabaja; elegir el accesorio justo supone una gran ayuda para simplificar y hacer más rápido el trabajo. Por esta razón, en la tercera sección del capítulo 1, dedicada a los accesorios para puntas de 1/4" hay muchas sugerencias y se tratan temas útiles para individuar de forma correcta el accesorio más idóneo para cada tipo de aplicación o lugar de trabajo.



# 1.3

## PORTAINSERI/ADATTATORI BIT HOLDERS/ADAPTERS PORTE EMOBOUTS/ADAPTATEURS PORTA PUNTAS/ADAPTADORES

1.3



### PORTAINSERI 1/4"C

1/4"C BIT HOLDER - PORTE-EMBOUITS 1/4"C - PORTA PUNTAS 1/4"C

		<b>MAGNETICI</b> MAGNETIC • À AIMANTS • MAGNÉTICOS	p. 199
		<b>SNODATI/FLESSIBILI</b> JOINTED/FLEXIBLE • ARTICULÉS/FLEXIBLES • ARTICULADOS / FLEXIBLES	p. 202
		<b>MAGNETICI CON BLOCCO</b> MAGNETIC WITH BLOCK • À AIMANT AVEC BLOCCAGE • MAGNÉTICOS CON BLOQUEO	p. 202
		<b>DOPPIO MAGNETE</b> TWO MAGNETS • DOUBLE AIMANT • DOBLE IMÁN	p. 206
		<b>ANTIGRAFFIO</b> SCRATCH-RESISTANT • ANTI-RAYURES • CONTRA LOS ARANAZOS	p. 207
		<b>NON MAGNETICI</b> NON-MAGNETIC • SANS AIMANT • NO MAGNÉTICOS	p. 210
		<b>ATTACCO SDS PLUS®</b> SDS PLUS® ATTACHMENT • QUEUE SDS PLUS® • EMPALME SDS PLUS®	p. 211
		<b>ATTACCO 5/16" RAPIDO</b> 5/16" QUICK ATTACHMENT • QUEUE 5/16" RAPIDE • EMPALME 5/16" RÁPIDO	p. 211
		<b>ATTACCO 5,5mm</b> 5.5 mm ATTACHMENT • QUEUE 5,5 mm • EMPALME 5,5mm	p. 211
		<b>CON IMPUGNATURA</b> WITH HANDLE • AVEC MANCHE • CON MANGO	p. 214
		<b>ATTACCO QUADRO</b> SQUARE ATTACHMENT • RACCORD CARRÉ • EMPALME CUADRADO	p. 215



### PORTAINSERI 1/4"E

1/4"E BIT HOLDER - PORTE-EMBOUITS 1/4"E- PORTA PUNTAS 1/4"E

		<b>ATTACCO 1/4"</b> 1/4" ATTACHMENT • QUEUE 1/4" • EMPALME 1/4"	p. 220
		<b>SNODATI/FLESSIBILI</b> JOINTED/FLEXIBLE • ARTICULÉS/FLEXIBLES • ARTICULADOS / FLEXIBLES	p. 220
		<b>CON IMPUGNATURA</b> WITH HANDLE • AVEC MANCHE • CON MANGO	p. 221
		<b>ATTACCO QUADRO</b> SQUARE ATTACHMENT • RACCORD CARRÉ • EMPALME CUADRADO	p. 221

### RINVII ANGOLARI

ANGLE DRIVER - RENVOI D'ANGLE - ANGULARES PORTA PUNTAS

	 	<b>PER INSERTE 1/4"C - 1/4"E</b> FOR BITS 1/4"C - 1/4"E • POUR EMBOUITS 1/4"C - 1/4"E • PARA PUNTAS 1/4"C - 1/4"E	p. 223
--	--	--	--------

### ADATTATORI - ADAPETRS - ADAPTATEURS - ADAPTADORES

		<b>ADATTATORI</b> ADAPETRS • ADAPTATEURS • ADAPTADORES	p. 227
--	---	--	--------

### ACCESSORI - ACCESSORIES - ACCESSOIRES - ACCESORIOS

	<b>MAGNETIZZATORI</b> MAGNETISERS • MAGNÉTISEURS • BLOQUE DE MAGNETIZACIÓN	p. 232
	<b>ESTRATTORI</b> EXTRACTORS • EXTRACTEURS • EXTRACTORES	p. 233

# PORTAINSERTI

## PORTAINSERTI PER INSERTI 1/4" C E LAME 1/4" E

Bit holder for 1/4" C bits and 1/4" E power-bits  
Porte embouts pour embouts 1/4" C et 1/4" E  
Porta puntas para puntas 1/4" C y 1/4" E

Corpo in acciaio INOX (HRA 64/66) resistente alle sollecitazioni trasmesse dall'inserto. Magnete permanente in Neodimio-Ferro-Boro; forza di trattenimento superiore del 100% a quanto richiesto dalle normative internazionali.

Body in STAINLESS steel (HRA 64/66), resistant to stress transmitted by the insert bit. Permanent magnet in Neodymium-Iron-Boro; retention strength greater than 100% as required by international standards.

Corps en acier inoxydable (HRA 64/66) résistant aux sollicitations transmises par l'embout. Aimant permanent en néodyme-fer-bore. Force de rétention supérieure de 100 % par rapport à ce qui est demandé par les réglementations internationales.

Cuerpo de acero INOX (HRA 64/66) resistente a los esfuerzos transmitidos por la punta. Imán permanente de Neodimio-Hierro-Boro; fuerza de retención superior al 100% de lo que requieren las normas internacionales.

Attacco in S2, lo stesso materiale utilizzato per la fabbricazione degli inserti Essential. Ottima resistenza all'usura.

Attachment in S2, the same material used to manufacture the Essential bits. Excellent wear resistance.

Queue en S2. Le même matériau utilisé pour la fabrication des embouts Essential. Excellente résistance à l'usure.

Empalme de S2, el mismo material que se usa para la fabricación de las puntas Essential. Óptima resistencia al desgaste.



Materie prime di ottima qualità utilizzate per la fabbricazione dei nostri porta-inserti, come gli inserti.

Our bit holders and bits are made using raw materials of the highest quality.

Matières premières d'excellente qualité utilisées dans la fabrication de nos porte-embouts, comme pour les embouts.

Materias primas de excelente calidad usadas para la fabricación de nuestros porta-puntas, al igual que para la fabricación DE LAS PUNTAS mismos.



Progettati per funzionare al meglio in coppia con tutti gli inserti della gamma LTI.

Designed to work best in combination with LTI range bits.

Conçus pour fonctionner au mieux en tandem avec tous les embouts de la gamme LTI.

Diseñados para funcionar mejor emparejados con todas las puntas de la gama LTI



Ampia scelta di soluzioni per rendere più facile qualsiasi operazione di assemblaggio.

Wide range of solutions to make any assembly operation easier.

Large gamme de solutions pour faciliter toutes les opérations d'assemblage.

Amplia gama de soluciones para facilitar cualquier operación de ensamblaje.



## 62013 MAGNETICI SENZA ANELLO

PORTAINSERI 1/4"E MAGNETICO PER INSERTE 1/4"C  
MAGNETIC 1/4"E BIT-HOLDER FOR 1/4"C BITS  
PORTE-EMBOUS 1/4"E MAGNÉTIQUE POUR EMOUS 1/4"C  
PORTA PUNTAS DE 1/4"E MAGNÉTICO PARA PUNTAS 1/4"C



**EASYPACK** | sacchetto PVC con Euro-hole • PVC bags with Euro-hole

L mm	Ø mm	PCS.	COD.	€ cad./each
50	10	5	62013004	3,890
60	10	5	62013005	4,020
75	10	5	62013010	4,820
100	10	5	62013015	8,840
120	10	5	62013020	12,400
150	10	5	62013025	12,900
200	10	5	62013030	14,500
250	10	5	62013035	23,600



**SELFPACK**  
1 pc.

L mm	COD.	€ box
50	62013004001	5,230
60	62013005001	5,360
75	62013010001	6,160
100	62013015001	10,200

## 62015 MAGNETICI CON ANELLO

PORTAINSERI MAGNETICO CON ANELLO C 1/4"E PER INSERTE 1/4"C  
MAGNETIC 1/4"E BIT-HOLDER WITH C RING FOR 1/4"C BITS  
PORTE-EMBOUS 1/4"E MAGNÉTIQUE AVEC BAGUE C POUR EMOUS 1/4"C  
PORTA PUNTAS DE 1/4"E MAGNÉTICO CON ANILLO C PARA PUNTAS 1/4"C



**EASYPACK** | sacchetto PVC con Euro-hole • PVC bags with Euro-hole

L mm	Ø mm	PCS.	COD.	€ cad./each
50	10	5	62015005	4,560
60	10	5	62015010	4,690
75	10	5	62015015	5,230
100	10	5	62015020	9,380
120	9,8	5	62015025	12,900
150	10	5	62015030	13,600
200	9,8	5	62015035	15,000
250	11	5	62015040	24,200
400	11	5	62015070	26,800



**SELFPACK**  
1 pc.

L mm	COD.	€ box
50	62015005001	5,900
60	62015010001	6,030
75	62015015001	6,570
100	62015020001	10,800
120	62015025001	14,200
150	62015030001	14,900
200	62015035001	16,400
250	62015040001	25,500





# 1.3 PORTAINSERTI/ADATTATORI

BIT HOLDERS/ADAPTERS  
PORTE EMOBOUTS/ADAPTATEURS  
PORTA INSERTOS/ADAPTADORES

62015

PORTAINSERTI INX



PORTAINSERTI 1/4"E IN ACCIAIO INOX INTEGRALE MAGNETICO CON ANELLO PER INSERTI 1/4"C  
1/4"E STAINLESS STEEL BIT HOLDER WITH C-RING AND MAGNET FOR 1/42C BITS  
PORTEMOBOUTS 1/4" EN ACIER INOXYDABLE MAGNETIQUE AVEC BAGUE C POUR EMOBOUTS 1/4"C  
PORTA PUNTAS DE 1/4"E EN ACERO INOXIDABLE MAGNETICO CON ANILLO C PARA PUNTAS 1/4"C

**NEW!**

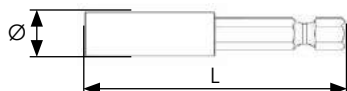

**EASYPACK** | sacchetto PVC con Euro-hole • PVC bags with Euro-hole

L mm	Ø mm	PCS.	COD.	€ cad./each
60	11	5	62015105	7,100

VEDI P.116  
SEE P. 116  
VOIR P. 116  
VÉASE P. 116



**SELFPACK**  
1 pc.

L mm	COD.	€ box
60	62015105001	8,390

62012

MAGNETE EXTRAFORTE  
CORPO RINFORZATO

PORTAINSERTI 1/4"E MAGNETICO CON ANELLO C PER INSERTI 1/4"C - PER BUSSOLE GUIDA  
MAGNETIC 1/4"E BIT-HOLDER WITH C RING FOR 1/4"C BITS - FOR FINDER SLEEVES  
PORTE-EMBOUITS 1/4"E MAGNÉTIQUE AVEC BAGUE C POUR EMOBOUTS 1/4"C - POUR DOUILLES DE GUIDAGE  
PORTA PUNTAS DE 1/4"E MAGNÉTICO CON ANILLO C PARA PUNTAS 1/4"C - PARA LLAVES GUÍA



**EASYPACK** | sacchetto PVC con Euro-hole • PVC bags with Euro-hole

L mm	Ø mm	PCS.	COD.	€ cad./each
60	11	5	62012005	7,160
75	11	5	62012010	7,450



**TIPS**



Portainseriti adatti all'utilizzo con inserti a taglio tipo lungo 61022 (p. 130) e bussole guida 61025 (p. 130).

Bit-holder suitable for use with long slotted bits, code 61022 (p. 130), and guide sockets, code 61025 (p. 130).

Porte-embout adapté à l'utilisation avec des embouts à fente de type long 61022 (p. 130) et douilles de guidage 61025 (p. 130).

Porta puntas ideales para usar con puntas de corte de tipo largo 61022 (p. 130) y llaves de vaso de guía 61025 (p. 130).





## 62035 PULSAR®



PORTAINSERI MAGNETICO ANTI-SHOCK PER AVVITATORI A MASSA BATTENTE  
ANTI-SHOCK MAGNETIC BIT-HOLDER FOR IMPACT WRENCHES  
PORTE-EMBOUTS MAGNÉTIQUE ANTI-CHOC POUR VISSSEUSE À CHOCS  
PORTA PUNTAS MAGNÉTICO ANTI-CHOQUE PARA ATORNILLADORES DE IMPACTO

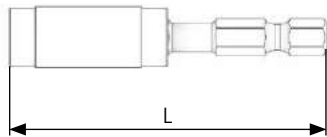

**EASYPACK** | sacchetto PVC con Euro-hole • PVC bags with Euro-hole

L mm	Ø mm	PCS.	COD.	€ cad./each
60	11	5	62035005	9,910

VEDI P. 55  
SEE P. 55  
VOIR P. 55  
VÉASE P. 55



**SELPACK**  
1 pc.

COD.	€ box
62035005001	11,300

1.3



## 62018 SNODATI

PORTAINSERI 1/4"E SNODATO CON BLOCCO PER INSERIRI 1/4"C  
ARTICULATED 1/4"E BIT HOLDER WITH LOCK FOR 1/4"C BITS  
PORTE-EMBOUTS 1/4"E ARTICULÉ AVEC BLOCAGE POUR EMBOUTS 1/4"C  
PORTA PUNTAS DE 1/4"E ARTICULADO CON BLOQUEO PARA PUNTAS 1/4"C

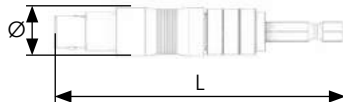

**EASYPACK** | sacchetto PVC con Euro-hole • PVC bags with Euro-hole

L mm	Ø mm	PCS.	COD.	€ cad./each
94	14	5	62018005	17,200



**SELPACK**  
1 pc.

L mm	Ø mm	COD.	€ box
94	14	62018005001	18,500



### FOCUS ON



Ideale per lavorare in spazi ridotti o scomodi dove non sia possibile avvitare in asse con la vite. Muovendo la ghiera può lavorare in posizione rettilinea.

Ideal for working in tight or difficult spaces where a second screw cannot be inserted. Move the ring nut to work in a straight position.

Idéal pour travailler dans des endroits exigus ou inconfortables, lorsqu'il n'est pas possible de visser en soutenant la vis. En déplaçant la bague, il est possible de travailler en position rectiligne.

Ideal para trabajar en espacios reducidos o incómodos donde no sea posible atornillar de forma alineada con el tornillo. Si se mueve la abrazadera es posible trabajar en posición rectilínea.





# 1.3 PORTAINSERTI/ADATTATORI

BIT HOLDERS/ADAPTERS  
PORTE EMOBOUTS/ADAPTATEURS  
PORTA INSERTOS/ADAPTADORES

## 62018 FLESSIBILI

PORTAINSERTI 1/4"E FLESSIBILE PER INSERTI 1/4"C  
FLEXIBLE 1/4"E BIT-HOLDER FOR 1/4"C BITS  
PORTE-EMBOUITS 1/4"E FLEXIBLE POUR EMOBOUTS 1/4"C  
PORTA PUNTAS DE 1/4"E FLEXIBLE PARA PUNTAS 1/4"C

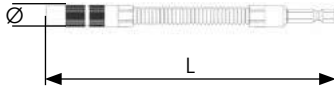

**EASYPACK** | sacchetto PVC con Euro-hole • PVC bags with Euro-hole

L mm	Ø mm	PCS.	COD.	€ cad./each
150	12	5	62018010	8,840



**SELFPACK**  
1 pc.

L mm	Ø mm	COD.	€ box
150	12	62018010001	10,200



### FOCUS ON

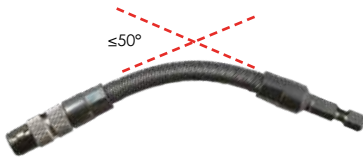

Grazie all'estrema flessibilità si presta a lavorare in spazi difficilmente raggiungibili.  
Its extreme flexibility is perfect for working in difficult to reach spaces.  
Grâce à la grande flexibilité, il permet de travailler dans des espaces difficiles à atteindre.  
Gracias a la extrema flexibilidad, es apto para trabajar en espacios a los que se puede llegar con dificultad.



## 62016 MANDRINO DI BLOCCO

PORTAINSERTI 1/4"E MAGNETICO CON MANDRINO DI BLOCCO PER INSERTI 1/4"C  
MAGNETIC 1/4"E BIT-HOLDER WITH LOCK CHUCK FOR 1/4"C BITS  
PORTE-EMBOUITS 1/4"E MAGNÉTIQUE AVEC MANDRIN DE BLOCAGE POUR EMOBOUTS 1/4"C  
PORTA PUNTAS DE 1/4"E MAGNÉTICO CON MANDRIL DE BLOQUEO PARA PUNTAS 1/4"C

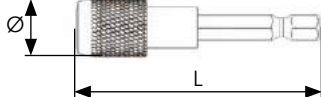

**EASYPACK** | sacchetto PVC con Euro-hole • PVC bags with Euro-hole

L mm	Ø mm	PCS.	COD.	€ cad./each
60	14	5	62016005	6,830
75	14	5	62016010	8,840
100	14	5	62016015	26,600
120	14	5	62016020	26,800
150	14	5	62016025	28,200
200	14	5	62016030	29,200
250	14	5	62016035	31,100



**SELFPACK**  
1 pc.

L mm	COD.	€ box
60	62016005001	8,170



### FOCUS ON



Le sfere di tenuta bloccano l'inserto: questo articolo è consigliato per l'uso con inserti esagonali che tendono a bloccarsi nella cava della vite.  
The sealing balls block the bit: this article is recommended for use with hexagon bits that tend to become blocked in the slot of the screw.  
Les billes bloquent l'embout: cet article est recommandé lors de l'utilisation d'embouts hexagonaux qui ont tendance à se coincer dans la fente de la vis.  
Las esferas de retención bloquean la punta: este artículo se aconseja para que se use con puntas hexagonales que tienden a bloquearse en la ranura del tornillo.





## 62016 PORTAINSERTI INX MANDRINO DI BLOCCO



PORTAINSERTI 1/4"E IN ACCIAIO INOX MAGNETICO CON MANDRINO DI BLOCCO  
1/4"E STAINLESS STEEL BIT HOLDER WITH LOCK CHUCK AND MAGNET  
PORTEMBOUTS 1/4" EN ACIER INOX MAGNETIQUE AVEC MANDRIN DE BLOPAGE  
PORTA PUNTAS DE 1/4"E EN ACERO INOX MAGNETICO CON MANDRIL DE BLOQUEO

**NEW!**

**EASYPACK** | sacchetto PVC con Euro-hole • PVC bags with Euro-hole

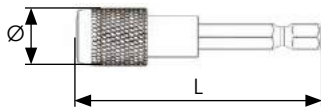

L mm	Ø mm	PCS.	COD.	€ cad./each
60	14	5	62016105	9,240

VEDI P. 116  
SEE P. 116  
VOIR P. 116  
VÉASE P. 116



**SELFPACK**  
1 pc.

L mm	COD.	€ box
60	62016105001	10,600



### FOCUS ON

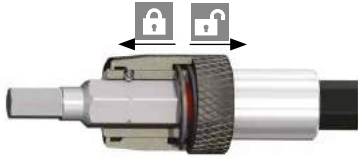

Le sfere di tenuta bloccano l'inserto: questo articolo è consigliato per l'uso con inserti esagonali che tendono a bloccarsi nella cava della vite.

The sealing balls block the bit: this article is recommended for use with hexagon bits that tend to become blocked in the slot of the screw.

Les billes bloquent l'embout: cet article est recommandé lors de l'utilisation d'embouts hexagonaux qui ont tendance à se coincer dans la fente de la vis.

Las esferas de retención bloquean la punta: este artículo se aconseja para que se use con puntas hexagonales que tienden a bloquearse en la ranura del tornillo.



## 62019 PORTAINSERTI EXTRA LUNGI CON GUIDA

P.INS. 1/4"E MAGNETICO EXTRA-LUNGO CON CANOTTO DI GUIDA PER INSERTI 1/4"C  
EXTRA LONG 1/4"E MAGNETIC BIT-HOLDER WITH GUIDE SLEEVE FOR 1/4"C BITS  
EXTRA LONG 1/4" E PORTE EMOBOUTS MAGNÉTIQUE AVEC MANCHE GUIDE POUR EMOBOUTS 1/4"C  
EXTRA LARGO PORTA PUNTAS DE 1/4"E MAGNETICO CON CASQUILLO DE GUIA PARA PUNTAS 1/4"C

**NEW!**

**EASYPACK** | sacchetto PVC con Euro-hole • PVC bags with Euro-hole

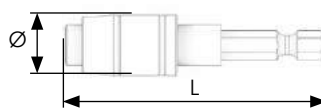

L mm	Ø mm	PCS.	COD.	€ cad./each
150	16	1	62019030	15,000
300	16	1	62019033	21,200
450	16	1	62019035	28,100



**SELFPACK**  
1 pc.

L mm	COD.	€ box
150	62019030001	16,300
300	62019033001	22,500
450	62019035001	29,400



### FOCUS ON



Questi portainseriti sono dotati di un canotto grazie al quale possono essere tenuti con le dita e quindi guidati con maggior precisione sulla testa della vite.

These bit holders are equipped with a tube thanks to which they can be held with fingers and then guided more precisely on the head of the screw.

Ces porte-embouts sont équipés d'un petit tube grâce auquel ils peuvent être tenus avec les doigts, puis guidés plus précisément sur la tête de la vis.

Estos portapuntas están equipados con un tubo que permite sujetar las puntas con los dedos y luego guiarlas con mayor precisión sobre la cabeza del tornillo.





# 1.3 PORTAINSERTI/ADATTATORI

BIT HOLDERS/ADAPTERS  
PORTE EMOBOUTS/ADAPTATEURS  
PORTA INSERTOS/ADAPTADORES

62019

## MANDRINO DI BLOCCO SGANCIO RAPIDO

PORTAINSERTI MAGNETICO 1/4"E CON MANDRINO, RAPIDO PER INSERTI 1/4"C  
1/4"E MAGNETIC BIT-HOLDER WITH QUICK CHUCK FOR 1/4"C BITS  
PORTE-EMBOUITS 1/4"E MAGNÉTIQUE AVEC MANDRIN, RAPIDE POUR EMOBOUTS 1/4"C  
PORTA PUNTAS DE 1/4"E MAGNÉTICO CON MANDRIL Y RÁPIDO PARA PUNTAS 1/4"C

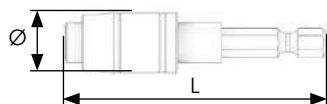

EASYPACK | sacchetto PVC con Euro-hole • PVC bags with Euro-hole

L mm	Ø mm	PCS.	COD.	€ cad./each
65	16	5	62019010	14,000



SELFPACK  
1 pc.

L mm	COD.	€ box
65	62019010001	15,300



### FOCUS ON



Sistema di espulsione rapida dell'inserto, ideale per chi lavora con guanti o a contatto con olio. Tirare la ghiera sia per inserire che per estrarre l'inserto.

Rapid expulsion system of the bit, ideal for those who work with gloves or in contact with oil. Pull the ring nut to insert and extract the insert bit.

Système d'éjection rapide de l'embout, idéal pour ceux qui travaillent avec des gants ou en contact avec l'huile. Tirer la bague pour insérer et extraire l'embout.

Sistema de expulsión rápido del la punta, ideal para quien trabaje con guantes o en contacto con el aceite. Tirar de la abrazadera ya sea para introducir que para quitar e la punta.



62036

## MANDRINO DI BLOCCO SGANCIO RAPIDO

PORTAINSERTI 1/4"E UNIVERSALE MAGNETICO CON SFERE CONCENTRICHE DI TENUTA  
BIT-HOLDER 1/4"E UNIVERSAL MAGNETIC WITH CONCENTRIC HOLDING BALLS  
PORTE-EMBOUITS 1/4 "ET UNIVERSSEL MAGNÉTIQUE AVEC DES BILLES DE SCELLEMENT CONCENTRIQUES  
PORTA PUNTAS 1/4" Y UNIVERSAL MAGNÉTICO CON ESFERAS CONCÉNTRICAS DE SUJECIÓN

NEW!

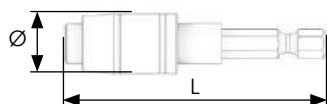

EASYPACK | sacchetto PVC con Euro-hole • PVC bags with Euro-hole

L mm	Ø mm	PCS.	COD.	€ cad./each
75	14	5	62036010	14,800
150	14	5	62036015	18,400
300	14	5	62036020	24,600



SELFPACK  
1 pc.

L mm	COD.	€ box
75	62036010001	16,050
150	62036015001	19,650
300	62036020001	25,850



### FOCUS ON



Tre sfere bloccano saldamente l'inserto all'interno del mandrino. Questo prodotto è indicato anche come prolunga per mechie.

Three balls hold the insert firmly inside the spindle. This product is also suitable for use as a mechanical extension.

Trois billes maintiennent fermement l'embout à l'intérieur de la broche. Ce produit est également indiqué comme une extension de mèche.

Tres esferas sujetan firmemente la punta en el mandril. Este producto también está indicado como prolongación para brocas de pala.





## 62019 MANDRINO DI BLOCCO SGANCIO RAPIDO

PORTAINSERI CORPO RIDOTTO MAGNETICO 1/4"E CON MANDRINO, RAPIDO PER INSERITI 1/4"C  
 1/4"E MAGNETIC REDUCED BODY BIT-HOLDER WITH QUICK CHUCK FOR 1/4"C BITS  
 PORTE-EMBOUTS RÉDUIT 1/4"E MAGNÉTIQUE AVEC MANDRIN, RAPIDE POUR EMBOUTS 1/4"C  
 PORTA PUNTAS CUERPO REDUCIDO DE 1/4"E MAGNÉTICO CON MANDRIL Y RÁPIDO PARA PUNTAS 1/4"C

**EASYPACK** | sacchetto PVC con Euro-hole • PVC bags with Euro-hole

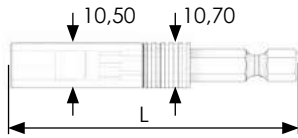

L mm	Ø mm	PCS.	COD.	€ cad./each
67	10,7	5	62019020	14,500



**SELPACK**  
1 pc.

L mm	COD.	€ box
67	62019020001	15,800



### FOCUS ON

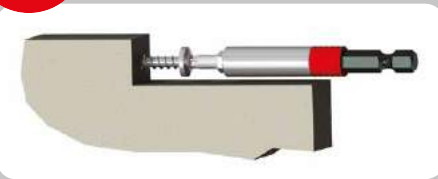

Corpo ridotto, sistema di bloccaggio e sgancio rapido dell'inserto. Ideale per spazi angusti o in caso di viti incassate.

Compact body, blocking and quick-release system of the bit. Ideal for small spaces or when using recessed screws.

Corps réduit, système de verrouillage et déclenchement rapide de l'embout. Idéal pour les espaces restreints ou en cas de vis encastrées.

Cuerpo reducido, sistema de bloqueo y de desenganche rápido de la punta. Ideal para espacios angostos o en caso de tornillos empotrados.



## 62019 MANDRINO DI BLOCCO SGANCIO RAPIDO

PORTAINSERI 1/4"E UNIVERSALE MAGNETICO CON MANDRINO E SGANCIO RAPIDO  
 UNIVERSAL MAGNETIC 1/4"E BIT-HOLDER WITH QUICK CHUCK  
 PORTE-EMBOUTS 1/4"E UNIVERSEL MAGNÉTIQUE AVEC MANDRIN ET DÉCLENCHÉMENT  
 PORTA PUNTAS DE 1/4"E UNIVERSAL MAGNÉTICO CON MANDRIL Y DESENGANCHE

**EASYPACK** | sacchetto PVC con Euro-hole • PVC bags with Euro-hole

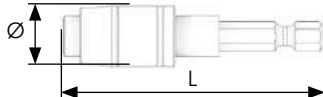

L mm	Ø mm	PCS.	COD.	€ cad./each
60	15	5	62019015	15,300



**SELPACK**  
1 pc.

L mm	COD.	€ box
60	62019015001	16,700



### FOCUS ON



Meccanismo di trattenimento adatto a tutti gli attacchi da 1/4". Per bloccare l'inserto basta spingerlo nella cava del portainseri, il mandrino si blocca automaticamente.

Retention mechanism suitable for all 1/4" attachments. To block the bit, simply push it into the slot of the bit-holder, the chuck will automatically lock into place.

Mécanisme de fixation qui s'adapte à tous les queues 1/4". Pour bloquer l'embout, il suffit de le pousser dans la fente du porte-embout. Le mandrin se bloque automatiquement.

Mecanismo de retención idóneo para todos los empalmes de 1/4". Para bloquear la punta es suficiente con empujarlo hacia la ranura del porta puntas, el mandril se bloqueará automáticamente.





# 1.3 PORTAINSERTI/ADATTATORI

BIT HOLDERS/ADAPTERS  
PORTE EMOBOUTS/ADAPTATEURS  
PORTA INSERTOS/ADAPTADORES

## 62017

### DOPPIO MAGNETE BATTUTA FISSA

PORTAINSERTI 1/4"E CON MAGNETE PER TRATTENIMENTO VITE PER INSERTI 1/4"C  
1/4"E BIT-HOLDER WITH MAGNET FOR SCREW RETENTION FOR 1/4"C BITS  
PORTE-EMBOUITS 1/4"E AVEC AIMANT POUR MAINTIEN VIS POUR EMOBOUTS 1/4"C  
PORTA PUNTAS DE 1/4"E CON IMÁN PARA RETENCIÓN TORNILLO PARA PUNTAS 1/4"C

EASYPACK | sacchetto PVC con Euro-hole • PVC bags with Euro-hole



L mm	Ø mm	PCS.	COD.	€ cad./each
60	15	5	62017005	10,500



SELPACK  
1 pc.

L mm	Ø mm	COD.	€ box
60	15	62017005001	11,800



#### FOCUS ON



Magnete ad anello per la testa della vite, profondità di avvitatura regolabile tramite la ghiera ideale per la messa in opera del cartongesso.

Ring magnets for the head of the screw, screwing depth can be adjusted via the ring nut, which makes it ideal for plasterboard.

Anneau magnétique pour la tête de la vis, profondeur de vissage réglable par la bague, idéal pour la pose des plaques de plâtre.

Mecanismo de retención idóneo para todos los empalmes de 1/4". Para bloquear e la punta es suficiente con empujarlo hacia la ranura del porta puntas, el mandril se bloqueará automáticamente.



## 62020

### DOPPIO MAGNETE BATTUTA AUTO-REGOLANTE

PORTAINSERTI 1/4"E CON MAGNETE SCORREVOLE PER INSERTI 1/4"C  
1/4"E BIT-HOLDER WITH SLIDING MAGNET FOR 1/4"C BITS  
PORTE-EMBOUITS 1/4"E AVEC AIMANT COULISSANTE POUR EMOBOUTS 1/4"C  
PORTA PUNTAS DE 1/4"E CON IMÁN DESLIZANTE PARA PUNTAS 1/4"C

EASYPACK | sacchetto PVC con Euro-hole • PVC bags with Euro-hole

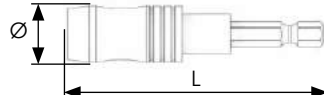

L mm	Ø mm	PCS.	COD.	€ cad./each
60	15	5	62020010	8,310
73	20	5	62020005*	13,200



SELPACK  
1 pc.

L mm	Ø mm	COD.	€ box
60	15	62020010001	9,650



#### FOCUS ON



Magnete ad anello per la testa della vite, la ghiera molleggiata si adatta a qualsiasi tipo di vite. L'articolo 62020005, con ghiera pivotante, è adatto all'uso con viti molto lunghe e pesanti.

Ring magnets for the head of the screw; the spring-loaded ring nut is suitable for any type of screw. Article 62020005, with pivoting ring nut, is suitable for very long and heavy screws.

Anneau magnétique pour la tête de la vis, la bague sur ressort s'adapte à n'importe quel type de vis. L'article 62020005 avec bague pivotante s'adapte à toutes les vis longues et lourdes.

Imán de anillo para la cabeza del tornillo, la abrazadera amortiguada se adapta a cualquier tipo de tornillo. El artículo 62020005, con abrazadera pivotante, es apto para un uso con tornillos muy largos y pesados.



**62020****PER CARTONGESSO  
SISTEMA SMART-STOP**

PORTAINSERI PER CARTONGESSO CON FRIZIONE SMART-STOP 1/4"E PER INSERITI 1/4"C  
 1/4"E BIT-HOLDER WITH SMART-STOP SYSTEM FOR DRY-WALL FOR 1/4"C BITS  
 AVEC SMART-STOP SYSTÈME POUR PLAQUES DE PLÂTRE PORTE-EMBOUTS 1/4"E POUR EMBOUTS 1/4"C  
 PORTA PUNTAS DE 1/4"E CON SMART-STOP SISTEMA PARA PLADUR PARA PUNTAS 1/4"C

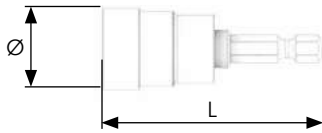
**EASYPACK** | sacchetto PVC con Euro-hole • PVC bags with Euro-hole

L mm	Ø mm	PCS.	COD.	€ cad./each
58	25	1	62020015	16,900



1.3

**FOCUS ON**

Magnete ad anello per la testa della vite, la frizione di sgancio contenuta nel corpo di questo portainseri garantisce una perfetta profondità di avvitatura a filo del piano.

Ring magnets for the screw head and the release friction contained in the body of this bit-holder guarantees perfect screwing depth, flush with the surface.

Anneau magnétique pour la tête de la vis. La friction de déclenchement contenue dans le corps de ce porte-embout garantit une profondeur parfaite de vissage au ras du plan.

Imán de anillo para la cabeza del tornillo. La fricción de desenganche contenida en el cuerpo de este portapuntas garantiza una perfecta profundidad de atornillado a ras de la superficie.

**62086****ANTIGRAFFIO**

PORTAINSERI MAGNETICO ANTI-GRAFFIO 1/4"E PER INSERITI 1/4"C  
 SCRATCH-RESISTANT MAGNETIC 1/4"E BIT-HOLDER FOR 1/4"C BITS  
 PORTE-EMBOUTS 1/4"E MAGNÉTIQUE ANTI-RAYURES POUR EMBOUTS 1/4"C  
 PORTA PUNTAS DE 1/4"E MAGNÉTICO RESISTENTE AL RAYADO PARA PUNTAS 1/4"C

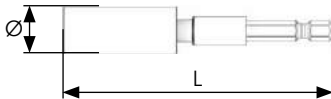
**EASYPACK** | sacchetto PVC con Euro-hole • PVC bags with Euro-hole

L mm	Ø mm	PCS.	COD.	€ cad./each
75	15	5	62086001	10,500

**SELPACK**  
1 pc.

L mm	COD.	€ box
75	62086001001	11,800

**FOCUS ON**

Il materiale antigraffio copre anche la testa della vite svolgendo anche funzione di bussola-guida. Per estrarre l'inserito far indietreggiare il canotto ed aiutarsi con una pinza.

The scratch-resistant material also covers the head of the screw, acting as a socket-guide. To extract the bit, push back the sleeve and pull it out with pliers.

La matière résistante aux rayures couvre également la tête de la vis en effectuant aussi une fonction de douille de guidage. Pour extraire l'embout, faire reculer le fourreau et s'aider d'une paire de pinces.

El material resistente al rayado también cubre la cabeza del tornillo, desempeñando una función de vaso de guía. Para extraer e la punta poner hacia atrás el cilindro y ayudarse con una pinza.





# 1.3 PORTAINSERTI/ADATTATORI

BIT HOLDERS/ADAPTERS  
PORTE EMBOUTS/ADAPTEURS  
PORTA INSERTOS/ADAPTADORES

## 66031 DISPLAY DA BANCO

ESPOSITORE DA BANCO IN PLEXIGLASS PER 24 PEZZI  
24 PCS. COUNTER PLEXIGLASS DISPLAY  
PRÉSENTOIR DE COMPTOIR EN PLEXIGLASS POUR 24 PIÈCES  
MOSTRADOR DE EXPOSICIÓN IN PLEXIGLASS PARA 24 PIEZAS



24  
pcs.

120 X 40 X 195 mm

COD. **66031008**  
€ 176,400



6pcs.  
COD. 62015010  
6pcs.  
COD. 62015015  
6pcs.  
COD. 62015020  
6pcs.  
COD. 62015030

COD. **66031014**  
€ 329,400



24pcs.  
COD. 62019015

COD. **66031009**  
€ 111,600



12pcs.  
COD. 62013005  
6pcs.  
COD. 62015015  
6pcs.  
COD. 62016005

COD. **66031015**  
€ 225,900



24pcs.  
COD. 62017005

COD. **66031011**  
€ 190,800



24pcs.  
COD. 62018010

COD. **66031016**  
€ 178,200



24pcs.  
COD. 62020010

COD. **66031012**  
€ 300,600



24pcs.  
COD. 62019010

COD. **66031017**  
€ 225,900



24pcs.  
COD. 62086001

COD. **66031013**  
€ 312,300



24pcs.  
COD. 62019020

COD. **66031018**  
€ 373,500



24pcs.  
COD. 62018005





**66001**

**STORE 6**

ASSORTIMENTI PORTAINSERI

CASSETTIERA CON 6 SCOMPARTI PER ESPOSITORE MULTISTORE  
DRAWERS WITH 6 COMPARTMENTS FOR MULTISTORE DISPLAY  
TIROIRS AVEC 6 COMPARTIMENTS POUR PRESENTOIR MULTISTORE  
6 CAJONES PARA MOSTRADOR DE EXPOSICIÓN TIPO MULTISTORE

40  
pcs.

COD. **66001120**

€ 239,000



600 X 115 X 65 mm



<p>62013005 </p> <p>60mm 10pcs.</p>	<p>62015015 </p> <p>75mm 10pcs.</p>	<p>62015020 </p> <p>100mm 5pcs.</p>
<p>62016005 </p> <p>60mm 5pcs.</p>	<p>62017005 </p> <p>60mm 5pcs.</p>	<p>62018005 </p> <p>94mm 5pcs.</p>

1.3



## MULTI STORE

COD. 66001005VC

PER DETTAGLI E COMPOSIZIONE VEDERE P. 184  
FOR DETAILS AND COMPOSITION SEE P. 184  
POUR LES DÉTAILS ET LA COMPOSITION VOIR P. 184  
PARA MÁS DETALLES Y COMPOSICIÓN VÉASE P. 184



# 1.3 PORTAINSERTI/ADATTATORI

BIT HOLDERS/ADAPTERS  
PORTE EMOBOUTS/ADAPTATEURS  
PORTA INSERTOS/ADAPTADORES

## 62016 MANDRINO DI BLOCCO

PORTAINSERTI 1/4"E CON MANDRINO DI BLOCCO PER INSERTI 1/4"C  
1/4"E BIT-HOLDER WITH CHUCK FOR 1/4"C BITS  
PORTE-EMBOUITS AVEC MANDRIN DE BLOCAGE 1/4"E POUR EMOBOUTS 1/4"C  
PORTA PUNTAS DE 1/4"E CON MANDRIL DE BLOQUEO PARA PUNTAS 1/4"C

**EASYPACK** | sacchetto PVC con Euro-hole • PVC bags with Euro-hole

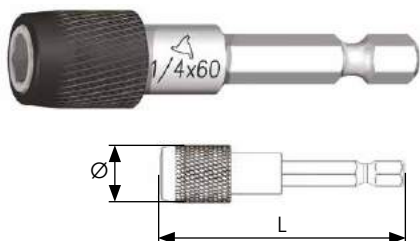

L mm	Ø mm	PCS.	COD.	€ cad./each
50	15	5	62016999	7,100



### FOCUS ON

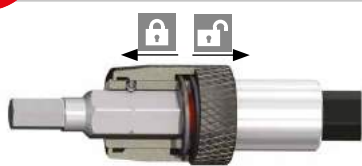

Le sfere di tenuta bloccano l'inserto: questo articolo è consigliato per l'uso con inserti esagonali che tendono a bloccarsi nella cava della vite.

The sealing balls block the insert: this article is recommended for using with hexagon bits that tend to stick in the slot of the screw.

Les billes bloquent l'embout : cet article est recommandé lors de l'utilisation d'embouts hexagonaux qui ont tendance à se coincer dans la fente de la vis.

Las esferas de retención bloquean a la punta: este artículo se aconseja para su uso junto a puntas hexagonales que tienden a bloquearse en la ranura del tornillo.



## 62014 GUIDE PER BUSSOLE

PORTAINSERTI 1/4"E CON ANELLO C PER INSERTI 1/4"C - PER BUSSOLE GUIDA  
1/4"E BIT-HOLDER WITH C RING FOR 1/4"C BITS - FOR FINDER SLEEVES  
PORTE-EMBOUITS 1/4"E AVEC BAGUE C POUR EMOBOUTS 1/4"C - POUR DOUILLES DE GUIDAGE  
PORTA PUNTAS DE 1/4"E CON ANILLO C PARA PUNTAS 1/4"C - PARA LLAVES DE VASO GUÍA

**EASYPACK** | sacchetto PVC con Euro-hole • PVC bags with Euro-hole

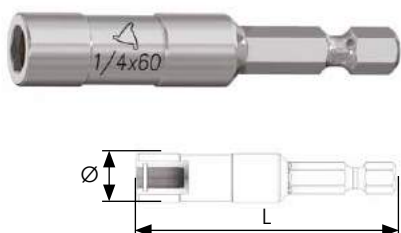

L mm	Ø mm	PCS.	COD.	€ cad./each
60	11	5	62014005	9,110



**SELPACK**  
1 pc.

L mm	COD.	€ box
60	62014005001	10,500



### TIPS



Portainseriti adattati all'utilizzo con inserti a taglio tipo lungo 61022 (p. 130) e bussole guida 61025 (p. 130).

Bit-holder suitable for use with long slotted bits, code 61022 (p. 130), and guide sockets, code 61025 (p. 130).

Porte-embout adapté à l'utilisation avec des embouts à fente de type long 61022 (p. 130) et douilles de guidage 61025 (p. 130).

Porta puntas ideales para usar con puntas de corte de tipo largo 61022 (p. 130) y llaves de vaso de guía 61025 (p. 130).

**62022****ATTACCO SDS-PLUS**

PORTAINSERTI SDS-PLUS® MAGNETICO CON ANELLO C PER INSERTI 1/4" C  
 MAGNETIC SDS-PLUS® BIT-HOLDER WITH C RING FOR 1/4" C BITS  
 PORTE-EMBOUTS SDS-PLUS® MAGNÉTIQUE AVEC BAGUE C POUR EMOBOUTS 1/4" C  
 PORTA PUNTAS SDS-PLUS® MAGNÉTICO CON ANILLO C PARA PUNTAS 1/4" C

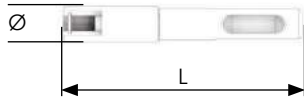
**EASYPACK** | sacchetto PVC con Euro-hole • PVC bags with Euro-hole

L mm	Ø mm	PCS.	COD.	€ cad./each
75	11	5	62022005	14,000

**62024****ATTACCO 5/16" RAPIDO**

PORTAINSERTI MAGNETICO CON ANELLO C 5/16" RAPIDO PER INSERTI 1/4" C  
 MAGNETIC 5/16" RAPID BIT-HOLDER WITH C RING FOR 1/4" C BITS  
 PORTE-EMBOUTS 5/16" RAPIDE MAGNÉTIQUE AVEC BAGUE C POUR EMOBOUTS 1/4" C  
 PORTA PUNTAS 5/16" RÁPIDO MAGNÉTICO CON ANILLO C PARA PUNTAS 1/4" C

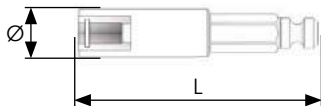
**EASYPACK** | sacchetto PVC con Euro-hole • PVC bags with Euro-hole

L mm	Ø mm	PCS.	COD.	€ cad./each
55	11	5	62024005	26,600

**62011****ATTACCO 5,5 mm**

PORTAINSERTI 5,5mm RAPIDO (A5,5) MAGNETICO CON ANELLO C PER INSERTI 1/4" C  
 MAGNETIC 5.5 mm (A5.5) RAPID BIT-HOLDER WITH C RING FOR 1/4" C BITS  
 PORTE-EMBOUTS 5,5mm RAPIDO (A5,5) MAGNÉTIQUE AVEC BAGUE C POUR EMOBOUTS 1/4" C  
 PORTA PUNTAS 5,5mm RÁPIDO (A5,5) MAGNÉTICO CON ANILLO C PARA PUNTAS 1/4" C

**EASYPACK** | sacchetto PVC con Euro-hole • PVC bags with Euro-hole

L mm	Ø mm	PCS.	COD.	€ cad./each
72	11	5	62011005	21,200

1.3





# 1.3 PORTAINSERTI/ADATTATORI

BIT HOLDERS/ADAPTERS  
PORTE EMBOUTS/ADAPTATEURS  
PORTA INSERTOS/ADAPTADORES

**64221**

## MINI-CRICCHETTI DOPPIA FUNZIONE

MINI-CRICCHETTO REVERSIBILE PER INSERTI 1/4" C E PER BUSSOLE 1/4"  
REVERSIBLE MINI-RATCHET FOR 1/4" C BITS AND 1/4" SOCKETS  
MINI-CLIQUET RÉVERSIBLE POUR EMBOUTS 1/4" C ET POUR DOUILLES 1/4"  
MINI LLAVE DE TRINQUETE REVERSIBLE PARA PUNTAS 1/4" C Y PARA LLAVES DE VASO DE 1/4"

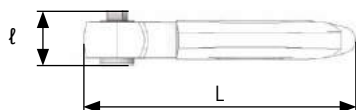

L mm	l mm	PCS.	COD.	€ cad./each
105	24	1	64221020	20,400

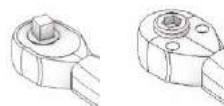

**64221**

## MINI CRICCHETTO REVERSIBILE

MINI CRICCHETTO PORTAINSERTI REVERSIBILE PER INSERTI 1/4" C  
MINI REVERSIBLE RATCHET BIT-HOLDER FOR 1/4" C BITS  
MINI CLIQUET REVERSIBLE PORTE EMBOUTS POUR EMBOUTS 1/4" C  
MINI CARRACA REVERSIBLE PARA PUNTAS DE 1/4" C

**NEW!**

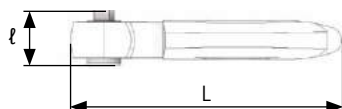

L mm	l mm	PCS.	COD.	€ cad./each
85	12,5	1	64221030	20,100





## 62032 CHIAVI PORTAININSERTI

CHIAVE A 90° PORTAININSERTI 1/4" C  
90° WRENCH 1/4" C BIT-HOLDER  
CLÉ À 90° PORTE-EMBOUTS 1/4 " C  
LLAVE A 90° PORTA PUNTAS DE 1/4" C



**EASYPACK** | sacchetto PVC con Euro-hole • PVC bags with Euro-hole

L mm	ℓ mm	PCS.	COD.	€ cad./each
110	32	6	62032005	7,230

1.3



## 62033 CHIAVI PORTAININSERTI MAGNETICHE

CHIAVE A 90° PORTAININSERTI 1/4" C MAGNETICA  
90° MAGNETIC 1/4" C BIT-HOLDER  
CLÉ À 90° PORTE-EMBOUTS MAGNÉTIQUE 1/4 " C  
LLAVE A 90° PORTA PUNTAS DE 1/4" C MAGNETICA



**EASYPACK** | sacchetto PVC con Euro-hole • PVC bags with Euro-hole

L mm	ℓ mm	PCS.	COD.	€ cad./each
110	32	6	62033005	7,900



# 1.3 PORTAINSERTI/ADATTATORI

BIT HOLDERS/ADAPTERS  
PORTE EMBOUTS/ADAPTATEURS  
PORTA INSERTOS/ADAPTADORES

62029

## GIRAVITE PORTAINSERTI MAGNETICI

GIRAVITE MAGNETICO PER INSERTI 1/4"C  
MAGNETIC SCREWDRIVER FOR 1/4"C BITS  
TOURNEVIS MAGNETIQUE POUR EMBOUTS 1/4"C  
DESTORNILLADOR MAGNÉTICO PARA PUNTAS 1/4"C

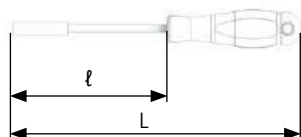

L mm	ℓ mm	PCS.	COD.	€ cad./each
215	100	1	62029005	10,600



62029

## GIRAVITE PORTAINSERTI A SGANCIO RAPIDO

GIRAVITE MAGNETICO PER INSERTI 1/4"C CON MANDRINO DI BLOCCO  
MAGNETIC SCREWDRIVER FOR 1/4"C INSERTS WITH BLOCK SPINDLE  
TOURNEVIS MAGNETIQUE POUR EMBOUTS 1/4 "C AVEC BROCHE BLOC  
DESTORNILLADOR MAGNÉTICO PARA PUNTAS DE 1/4" CON MANDRIL DE BLOQUEO

**EASYPACK** | sacchetto PVC con Euro-hole • PVC bags with Euro-hole

**NEW!**



L mm	ℓ mm	PCS.	COD.	€ cad./each
210	90	6	62029030	14,200

62029

## GIRAVITE PORTAINSERTI MAGNETICI FLESSIBILI

GIRAVITE MAGNETICO FLESSIBILE PER INSERTI 1/4"C  
FLEXIBLE MAGNETIC SCREWDRIVER FOR 1/4"C BITS  
TOURNEVIS MAGNETIQUE FLEXIBLE POUR EMBOUTS 1/4"C  
DESTORNILLADOR MAGNÉTICO FLEXIBLE PARA PUNTAS 1/4"C

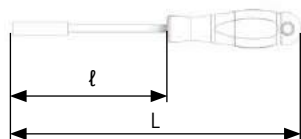

L mm	ℓ mm	PCS.	COD.	€ cad./each
350	250	1	62029010	18,300

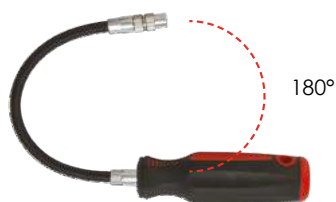

**62025****ATTACCO QUADRO 1/4" CON SFERA**

PORTAINSERI 1/4" CON SFERA PER INSERTI 1/4"C  
 1/4" BIT-HOLDER WITH BALL FOR 1/4"C BITS  
 PORTE-EMBOUTS 1/4" AVEC BILLE POUR EMOBOUTS 1/4"C  
 PORTA PUNTAS 1/4" CON ESFERA PARA PUNTAS 1/4"C

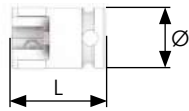
**EASYPACK** | sacchetto PVC con Euro-hole • PVC bags with Euro-hole

L mm	Ø mm	PCS.	COD.	€ cad./each
25	12	1	62025010	2,950

**62025****ATTACCO QUADRO 1/4" CON ANELLO**

PORTAINSERI 1/4" CON ANELLO C PER INSERTI 1/4"C  
 1/4" BIT-HOLDER WITH C RING FOR 1/4"C BITS  
 PORTE-EMBOUTS 1/4" AVEC BAGUE C POUR EMOBOUTS 1/4"C  
 PORTA PUNTAS 1/4" CON ANILLO C PARA PUNTAS 1/4"C

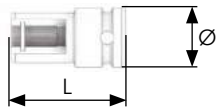
**EASYPACK** | sacchetto PVC con Euro-hole • PVC bags with Euro-hole

L mm	Ø mm	PCS.	COD.	€ cad./each
30	13	1	62025005	6,700

**SELPACK**  
1 pc.

L mm	COD.	€ box
30	62025005001	8,040

**62023****ATTACCO QUADRO 1/4" CON MANDRINO DI BLOCCO**

PORTAINSERI 1/4" CON MANDRINO DI BLOCCO PER INSERTI 1/4"C  
 1/4" BIT-HOLDER WITH CHUCK FOR 1/4"C BITS  
 PORTE-EMBOUTS 1/4" AVEC MANDRIN DE BLOCAGE POUR EMOBOUTS 1/4"C  
 PORTA PUNTAS CON MANDRIL DE BLOQUEO 1/4" PARA PUNTAS 1/4"C

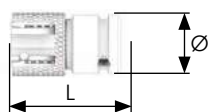
**EASYPACK** | sacchetto PVC con Euro-hole • PVC bags with Euro-hole

L mm	Ø mm	PCS.	COD.	€ cad./each
32	13	1	62023005	16,100





# 1.3 PORTAINSERTI/ADATTATORI

BIT HOLDERS/ADAPTERS  
PORTE EMBOUTS/ADAPTATEURS  
PORTA INSERTOS/ADAPTADORES

62027

## ATTACCO QUADRO 3/8\"/> CON SFERA

PORTAINSERTI CON SFERA 3/8\" PER INSERTI 1/4\"C  
3/8\" BIT-HOLDER WITH BALL FOR 1/4\"C BITS  
PORTE-EMBOUTS 3/8\" AVEC BILLE POUR EMBOUTS 1/4\"C  
PORTA PUNTAS CON ESFERA 3/8\" PARA PUNTAS 1/4\"C

**EASYPACK** | sacchetto PVC con Euro-hole • PVC bags with Euro-hole

L mm	Ø mm	PCS.	COD.	€ cad./each
28	17	1	62027010	3,890

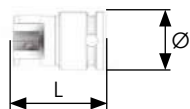

62027

## ATTACCO QUADRO 3/8\"/> CON ANELLO

PORTAINSERTI CON ANELLO C 3/8\" PER INSERTI 1/4\"C  
3/8\" BIT-HOLDER WITH C RING FOR 1/4\"C BITS  
PORTE-EMBOUTS 3/8\" AVEC BAGUE C POUR EMBOUTS 1/4\"C  
PORTA PUNTAS CON ANILLO C 3/8\" PARA PUNTAS 1/4\"C

**EASYPACK** | sacchetto PVC con Euro-hole • PVC bags with Euro-hole

L mm	Ø mm	PCS.	COD.	€ cad./each
38	19	1	62027005	9,110

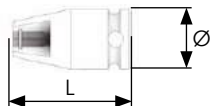





**62028**

## ATTACCO QUADRO 3/8" CON MANDRINO DI BLOCCO

PORTAINSERI CON MANDRINO DI BLOCCO 3/8" PER INSERTI 1/4" C  
3/8" BIT-HOLDER WITH CHUCK FOR 1/4" C BITS  
PORTE-EMBOUS 3/8" AVEC MANDRIN DE BLOCAGE POUR EMOUS 1/4" C  
PORTA PUNTAS 3/8" CON MANDRIL DE BLOQUEO PARA PUNTAS 1/4" C

**EASYPACK** | sacchetto PVC con Euro-hole • PVC bags with Euro-hole

L mm	Ø mm	PCS.	COD.	€ cad./each
37	19	1	62028005	22,500

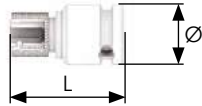

1.3



**62030**

## ATTACCO QUADRO 3/8" MAGNETICO CON ANELLO

PORTAINSERI 3/8" MAGNETICO CON ANELLO C PER INSERTI 1/4" C  
MAGNETIC 3/8" BIT-HOLDER WITH C RING FOR 1/4" C BITS  
PORTE-EMBOUS 3/8" AIMANTÉ AVEC BAGUE C POUR EMOUS 1/4" C  
PORTA PUNTAS 3/8" MAGNÉTICO CON ANILLO C PARA PUNTAS 1/4" C

**EASYPACK** | sacchetto PVC con Euro-hole • PVC bags with Euro-hole

L mm	Ø mm	PCS.	COD.	€ cad./each
35	19	1	62030005	34,300

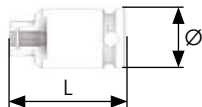



# 1.3 PORTAINSERTI/ADATTATORI

BIT HOLDERS/ADAPTERS  
PORTE EMOBOUTS/ADAPTATEURS  
PORTA INSERTOS/ADAPTADORES

**62031**

## ATTACCO QUADRO 1/2" CON SFERA

PORTAINSERTI 1/2" CON SFERA PER INSERTI 1/4"C  
1/2" BIT-HOLDER WITH BALL FOR 1/4"C BITS  
PORTE-EMBOUITS 1/2" AVEC BILLE POUR EMOBOUTS 1/4"C  
PORTA PUNTAS 1/2" CON ESFERA PARA PUNTAS 1/4"C

**EASYPACK** | sacchetto PVC con Euro-hole • PVC bags with Euro-hole

L mm	Ø mm	PCS.	COD.	€ cad./each
38	22	1	62031010	5,090

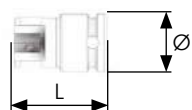

**62031**

## ATTACCO QUADRO 1/2" CON ANELLO

PORTAINSERTI 1/2" CON ANELLO C PER INSERTI 1/4"C  
1/2" BIT-HOLDER WITH C RING FOR 1/4"C BITS  
PORTE-EMBOUITS 1/2" AVEC BAGUE C POUR EMOBOUTS 1/4"C  
PORTA PUNTAS 1/2" CON ANILLO C PARA PUNTAS 1/4"C

**EASYPACK** | sacchetto PVC con Euro-hole • PVC bags with Euro-hole

L mm	Ø mm	PCS.	COD.	€ cad./each
35	24	1	62031015	12,500

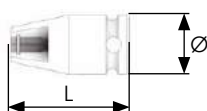

**62031**

## ATTACCO QUADRO 1/2" CON MANDRINO DI BLOCCO

PORTAINSERTI 1/2" CON MANDRINO DI BLOCCO PER INSERTI 1/4"C  
1/2" BIT-HOLDER WITH CHUCK FOR 1/4"C BITS  
PORTE-EMBOUITS 1/2" AVEC MANDRIN DE BLOCAGE POUR EMOBOUTS 1/4"C  
PORTA PUNTAS 1/2" CON MANDRIL DE BLOQUEO PARA PUNTAS 1/4"C

**EASYPACK** | sacchetto PVC con Euro-hole • PVC bags with Euro-hole

L mm	Ø mm	PCS.	COD.	€ cad./each
45	25	1	62031005	22,700

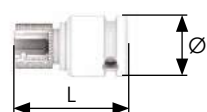



# COME SCEGLIERE IL PORTAINSERTO

HOW TO CHOOSE A BIT HOLDER  
COMMENT CHOISIR LE PORTE-EMBOUT  
CÓMO ELEGIR EL PORTA PUNTA

## NON MAGNETICI

Non-magnetic  
Sans aimant  
No magnéticos

RECOMMENDED



Quando si lavora in presenza di limatura, polvere o trucioli d ferro.

For working in the presence of filings, dust or iron shavings.

Lorsqu'il faut travailler en présence de limaille, de poussière ou de copeaux en fer.

Quando se trabaja ante la presencia de limadura, polvo o virutas de hierro.

## DOPPIO MAGNETE

Double magnets  
Double aimant  
Doble imán

RECOMMENDED



Con viti di grosse dimensioni o lunghe (viti per coperture edilizie).

With large or long screws (screws for building roofs).

Avec des grandes ou longues vis (vis de toiture).

Con tornillos de grandes dimensiones o largos (tornillos para coberturas de la construcción).

## SGANCIO RAPIDO

Quick release  
Déclenchement rapide  
Desenganche rápido

RECOMMENDED



Se si devono indossare guanti, o se le mani sono sporche di olio.

If you have to wear gloves or if your hands are oily.

S'il faut porter des gants, ou si les mains sont souillées d'huile.

Si hay que usar guantes o si las manos están sucias de aceite.

## SNODATI O FLESSIBILI

Jointed or flexible  
Articulés ou flexibles  
Articulados o flexibles

RECOMMENDED



Vicino ad uno spigolo (zoccolini, mobili, cassette, motori di auto, parafanghi).

Close to an edge (skirting boards, furniture, drawers, car engines, mudguards).

À proximité d'un angle (plinthes, meubles, tiroirs, moteurs de voiture, garde-boue).

Cerca de una arista (zócalos, muebles, cajones, motores de automóviles, parachoques).

## MANDRINO DI BLOCCO

Chuck  
Mandrin de blocage  
Mandril de bloqueo

RECOMMENDED



Se l'inserto si blocca nella cava della vite, se il punto in cui va posizionata la vite è difficilmente raggiungibile.

If the bit becomes stuck in the slot of the screw, if the point where the screw is to be positioned is difficult to reach.

Si l'embout se bloque dans la fente de la vis, si le point où la vis sont placés dans un endroit difficile à atteindre.

Si la punta se bloquea en la ranura del tornillo; si es difícil llegar al punto en donde se coloca el tornillo.

## BUSSOLE MAGNETICHE

Magnetic sockets  
Douilles magnétiques  
Vasos magnéticos

RECOMMENDED



In caso di fori profondi o alloggiamenti particolarmente stretti.

In case of deep holes or particularly tight seats.

En cas de trous profonds ou de logements particulièrement étroits.

En caso de orificios profundos o de alojamientos particularmente estrechos.

1.3





# 1.3 PORTAINSERTI/ADATTATORI

BIT HOLDERS/ADAPTERS  
PORTE EMOBOUTS/ADAPTATEURS  
PORTA INSERTOS/ADAPTADORES

62019

## MANDRINO DI BLOCCO SGANCIO RAPIDO

PORTAINSERTI 1/4"E UNIVERSALE MAGNETICO CON MANDRINO E SGANCIO  
UNIVERSAL MAGNETIC 1/4"E BIT-HOLDER WITH QUICK CHUCK  
PORTE-EMBOBOUTS 1/4"E UNIVERSEL MAGNETIQUE AVEC MANDRIN ET DÉCLENCHEMENT  
PORTA PUNTAS DE 1/4"E UNIVERSAL MAGNETICO CON MANDRIL Y DESENGANCHE

EASYPACK | sacchetto PVC con Euro-hole • PVC bags with Euro-hole

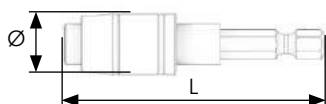

L mm	Ø mm	PCS.	COD.	€ cad./each
60	15	5	62019015	15,300



SELFPACK  
1 pc.

L mm	COD.	€ box
60	62019015001	16,700



### FOCUS ON



Meccanismo di trattenimento adatto a tutti gli attacchi da 1/4". Per bloccare l'inserto basta spingerlo nella cava del portainseri, il mandrino si blocca automaticamente.

Retention mechanism suitable for all 1/4" attachments. To block the bit, simply push it into the slot of the bit-holder, the chuck will automatically lock into place.

Mécanisme de fixation qui s'adapte à tous les queues 1/4". Pour bloquer l'embout, il suffit de le pousser dans la fente du porte-embout. Le mandrin se bloque automatiquement.

Mecanismo de retención idóneo para todos los empalmes de 1/4". Para bloquear la punta es suficiente con empujarlo hacia la ranura del porta puntas, el mandril se bloqueará automáticamente.



62055

## SUPER-FLESSIBILI

PORTAINSERTI 1/4"E SUPER-FLESSIBILE PER INSERTI 1/4"C  
EXTRA-FLEXIBLE 1/4"E BIT-HOLDER FOR 1/4"C BITS  
PORTE-EMBOBOUTS 1/4"E SUPER-FLEXIBLE POUR EMOBOUTS 1/4"C  
PORTA PUNTAS DE 1/4"E SUPER-FLEXIBLE PARA PUNTAS 1/4"C

EASYPACK | sacchetto PVC con Euro-hole • PVC bags with Euro-hole



L mm	Ø mm	PCS.	COD.	€ cad./each
300	16	1	62055005	53,900



### FOCUS ON

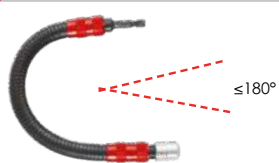

Grazie all'estrema flessibilità si presta a lavorare in spazi difficilmente raggiungibili.

Its extreme flexibility is perfect for working in difficult positions or to reach narrow spaces.

Grâce à la grande flexibilité, il permet de travailler dans des espaces difficiles à atteindre.

Gracias a la extrema flexibilidad, es apto para trabajar en espacios a los que se puede llegar con dificultad.



**62029****IMPUGNATURE PORTAINSERTI**

IMPUGNATURA CON SFERA PER LAME 1/4"E  
 HANDLE WITH BALL FOR 1/4"E POWER-BITS  
 POIGNÉE AVEC BILLE POUR EMBOUTS 1/4 "E  
 MANGO CON ESFERA PARA PUNTAS 1/4"E

**EASYPACK** | sacchetto PVC con Euro-hole • PVC bags with Euro-hole

L mm	PCS.	COD.	€ cad./each
125	1	62029015	10,100

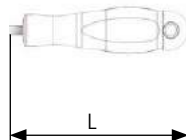
**62051****ATTACCO QUADRO 3/8" CON SFERA**

PORTAINSERTI 3/8" CON SFERA PER LAME 1/4"E  
 3/8" BIT-HOLDER WITH BALL FOR 1/4"E POWER-BITS  
 PORTE-EMBOUTS 3/8" AVEC BILLE POUR EMBOUTS 1/4"E  
 PORTA PUNTAS 3/8" CON ESFERA PARA PUNTAS 1/4"E

**EASYPACK** | sacchetto PVC con Euro-hole • PVC bags with Euro-hole

L mm	Ø mm	PCS.	COD.	€ cad./each
42	19	1	62051005	32,200

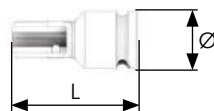
**62054****ATTACCO QUADRO 3/8" CON MANDRINO DI BLOCCO**

PORTAINSERTI 3/8" CON MANDRINO DI BLOCCO PER LAME 1/4"E  
 3/8" BIT-HOLDER WITH CHUCK FOR 1/4"C POWER-BITS  
 PORTE-EMBOUTS 3/8" AVEC MANDRIN DE BLOCAGE POUR EMBOUTS 1/4"E  
 PORTA PUNTAS 3/8" CON MANDRIL DE BLOQUEO PARA PUNTAS 1/4"E

**EASYPACK** | sacchetto PVC con Euro-hole • PVC bags with Euro-hole

L mm	Ø mm	PCS.	COD.	€ cad./each
42	19	1	62054006*	72,400
55	19	1	62054005	37,500

\* IMPACT

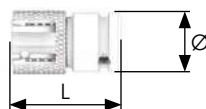

1.3



# RINVII ANGOLARI

## RINVII ANGOLARI PER INSERTI 1/4" C E LAME 1/4" E

Angle heads for 1/4" C bits and 1/4" E power-bits

Renvois d'angle pour embouts 1/4" C et 1/4" E

Angulares porta puntas para puntas 1/4" C e 1/4" E



### INDUSTRIAL

1

Ingranaggi del giunto con coppia conica ipoide.

Gear coupling with hypoid bevel gear pair.

Engrenages du joint avec couple conique hypoïde.

Engranajes del acoplador con par de torsión cónica hipóide.

2

Guide dell'albero temprate e rettificate.

Hardened and ground shaft guide.

Guides de l'arbre trempés et rectifiés.

Guías del eje templadas y rectificadas.

3

Resistenza allo sforzo di torsione garantita oltre a 65 Nm.

Resistance to torsional stress is guaranteed at over 65 Nm.

Résistance à la contrainte de torsion garantie à plus de 65 Nm.

Resistencia al esfuerzo de torsión garantizada a más de 65 Nm.



#### TIPS

Non utilizzare con avvitatori ad impulsivi - Do not use with impact wrenches

Ne pas utiliser avec visseuses à masse battante - No utilizar con los atornilladores de impacto

### PROFESSIONAL

1

Ingranaggi del giunto con coppia conica semplice.

Gear coupling with simple bevel gear pair.

Engrenages du joint avec couple conique simple.

Engranajes del acoplador con par de torsión cónica simple.

2

Testa ribassata, manico pivotante e/o estraibile.

Low-rise head, pivoting and/or extractable handle.

Tête surbaissée, poignée pivotant et/ou amovible.

Cabeza rebajada, mango basculante y/o extraíble.

3

Resistenza allo sforzo di torsione garantita fino a 40 Nm.

Resistance to torsional stress is guaranteed up to 40 Nm.

Résistance à la contrainte de torsion garantie jusqu'à 40 Nm.

Resistencia al esfuerzo de torsión garantizada hasta 40 Nm.



#### TIPS

Non utilizzare con avvitatori ad impulsivi - Do not use with impact wrenches

Ne pas utiliser avec visseuses à masse battante - No utilizar con los atornilladores de impacto



## 62034 RINVII ANGOLARI 90° INDUSTRIALI

RINVIO ANGOLARE 90° PER INSERTI 1/4" C - ALTA RESISTENZA - INDUSTRIALE  
 90° ANGLE DRIVER FOR 1/4" C BITS - HIGH RESISTANCE - INDUSTRIAL  
 RENVOI D'ANGLE 90° POUR EMBOUTS 1/4" C - HAUTE RÉSISTANCE - INDUSTRIEL  
 ANGULAR DE 90° PARA PUNTAS 1/4" C - DE ALTA RESISTENCIA - INDUSTRIAL

65 Nm



L mm	ℓ mm	PCS.	COD.	€ cad./each
125	37	1	62034006	57,600

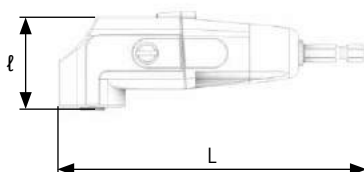

77 X 175 mm

1.3



### FOCUS ON



Cuscinetti di alta qualità, alberi temprati rettificati, coppia conica ipoide per una rotazione fluida. Utensile adatto ad usi industriali intensivi. Facile manutenzione.

High quality bearings, ground tempered shafts, hypoid bevel coupling for smooth rotation. Tool suitable for heavy-duty industrial use. Easy maintenance.

Roulements haute qualité, arbres trempés rectifiés, couples coniques hypoïdes, pour une rotation fluide. Outil adapté aux utilisations industrielles intensives. Facile à entretenir.

Engranajes de alta calidad, ejes templados rectificados, par de torsión cónica hipóide para una fluida rotación. Utensilio apto para usos industriales intensivos. Fácil mantenimiento.



## 62034 MINI RINVII ANGOLARI 90° PROFESSIONALI

RINVIO ANGOLARE 90° CON MANDRINO DI BLOCCO PER INSERTI 1/4" C  
 90° ANGLE DRIVER WITH CHUCK FOR 1/4" C BITS  
 RENVOI D'ANGLE 90° AVEC MANDRIN DE BLOCAGE POUR EMBOUTS 1/4" C  
 ANGULAR DE 90° CON MANDRIL DE BLOQUEO PARA PUNTAS 1/4" C

40 Nm



L mm	ℓ mm	PCS.	COD.	€ cad./each
83	46	1	62034010	34,800

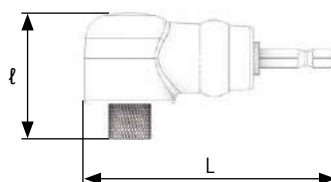

85 X 190 mm



### FOCUS ON



Pratico e compatto con manico pivotante e serrabile in 8 diverse posizioni viene fornito con un inserto PH2x25, confezionato in blister.

Compact and practical, with pivoting handle that can be locked in eight different positions. Comes with a PH2x25 bit in a blister pack.

Pratique et compact avec poignée pivotante et verrouillable sur 8 différentes positions, il est livré avec un embout PHx25, emballé sous blister.

Práctico y compacto con mango pivotante y que se puede cerrar en 8 diferentes posiciones, se suministra con una punta PH2x25, en plástico de burbujas.





# 1.3 PORTAINSERTI/ADATTATORI

BIT HOLDERS/ADAPTERS  
PORTE EMBOUTS/ADAPTATEURS  
PORTA INSERTOS/ADAPTADORES

## 62034 RINVII ANGOLARI 90° PROFESSIONALI

RINVIO ANGOLARE 90° CON TESTA RIBASSATA PER INSERTI 1/4" C  
90° ANGLE HEAD WITH LOW-RISE HEAD FOR 1/4" BITS  
RENVOI D'ANGLE 90° AVEC TÊTE SURBAISSÉE POUR EMBOUTS 1/4" C  
ANGULAR DE 90° CON CABEZA REBAJADA PARA PUNTAS 1/4" C

40 Nm



L mm	ℓ mm	PCS.	COD.	€ cad./each
136	32	1	62034020	45,000

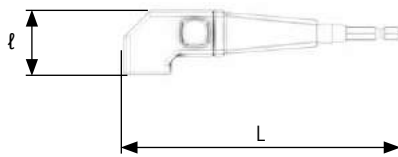

80 X 185 mm



### FOCUS ON

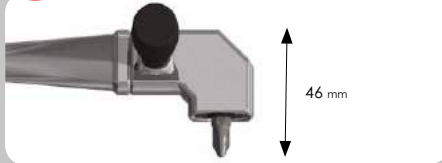

Testa ribassata per raggiungere le posizioni più difficili. Leggero e maneggevole grazie alla scocca in alluminio. Manico dotato di serbatoio per inserti.

Low-rise head to reach the most difficult positions. Lightweight and easy to handle thanks to its aluminium body. Handle equipped with bit container.

Tête surbaissée pour atteindre les positions les plus difficiles. Léger et facile à manipuler grâce à la coque en aluminium. Poignée avec rangement pour les embouts.

Cabeza rebajada para alcanzar las posiciones más difíciles. Ligero y manejable gracias al chasis de aluminio. Mango provisto de almacenaje para las puntas.



## 62053 RINVII ANGOLARI 90° PROFESSIONALI PER LAME 1/4" E

RINVIO ANGOLARE 90° CON MANDRINO DI BLOCCO PER LAME 1/4" E  
90° ANGLE DRIVE WITH CHUCK FOR 1/4" C POWER-BITS  
RENVOI D'ANGLE 90° AVEC MANDRIN DE BLOCAGE POUR EMBOUTS 1/4" E  
ANGULAR DE 90° CON MANDRIL DE BLOQUEO PARA PUNTAS 1/4" E

40 Nm



L mm	ℓ mm	PCS.	COD.	€ cad./each
136	47	1	62053006	59,000

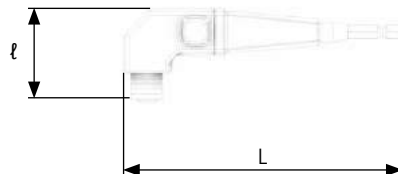

90 X 185 mm



### FOCUS ON



Mandrino di blocco per lame 1/4" E. Leggero e maneggevole grazie alla scocca in alluminio. Manico dotato di serbatoio per inserti.

Chuck for 1/4" E power bits. Lightweight and easy to handle thanks to its aluminium body. Handle equipped with bit container.

Mandrill de verrouillage pour lames 1/4" E. Léger et maniable grâce à la coque en aluminium. poignée avec rangement pour les embouts.

Mandril de bloqueo para lamas de 1/4" E. Ligero y manejable gracias al chasis de aluminio. Mango provisto de almacenaje para las puntas.





**62034**

## RINVII ANGOLARI 80° PROFESSIONALI

RINVIO ANGOLARE 80° PER INSERTI 1/4" C  
80° ANGLE DRIVER FOR 1/4" C BITS  
RENVOI D'ANGLE 80° POUR EMBOUTS 1/4" C  
ANGULAR DE 80° PARA PUNTAS 1/4" C

20 Nm

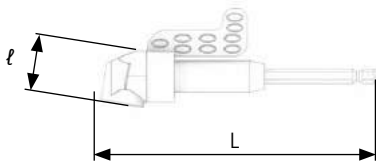

L mm	l mm	PCS.	COD.	€ cad./each
138	27	1	62034025	16,500



95 X 167 mm

1.3



**62034**

## RINVII ANGOLARI 80° CON IMPUGNATURA

RINVIO ANGOLARE 80° CON IMPUGNATURA ESTRAIBILE PER INSERTI 1/4" C  
80° ANGLE DRIVER WITH EXTRACTABLE HANDLE FOR 1/4" C BITS  
RENVOI D'ANGLE 80° AVEC POIGNÉE EXTRAÏBLE POUR EMBOUTS 1/4" C  
ANGULAR DE 80° CON MANGO EXTRAÏBLE PARA PUNTAS 1/4" C

20 Nm

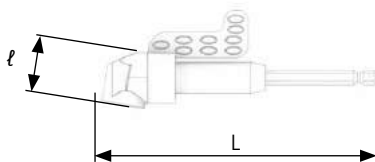

L mm	l mm	PCS.	COD.	€ cad./each
138	27	1	62034015	26,600



110 X 300 mm



### FOCUS ON



Ridotte dimensioni della testa, manico sfilabile.  
Compact head size, removable handle.  
Tête aux dimensions réduites, poignée amovible.  
Reducidas dimensiones de la cabeza, mango extraíble.

# ADATTATORI

## ADATTATORI PER BUSSOLE 1/4" C E 1/4" E

Adapters for 1/4" C and 1/4" E sockets

Adaptateurs pour douilles 1/4" C et 1/4" E

Adaptadores para vasos 1/4" C y 1/4" E

**A** = secondo DIN 3121 Forma E, con perno di trattenimento in acciaio per molle. Indicati per l'utilizzo con bussole IMPACT; il perno assicura il bloccaggio della bussola evitandone la perdita anche su impianti automatici.

**A** = according to DIN 3121 Form E Standard, with retention pin in spring steel. Suitable for use with IMPACT sockets; the pin ensures the locking of the socket, preventing loss even on automatic systems.

**A** = selon DIN 3121 forme E, avec goupille de retenue en acier pour ressorts. Adapté pour l'utilisation avec les douilles IMPACT. Le goujon garantit le blocage de la douille en évitant la perte même sur les installations automatiques.

**A** = según DIN 3121 Forma E, con perno de retención de acero para resortes. Aptos para un uso con llaves de vaso IMPACT; el perno asegura el bloqueo de la llave tubular evitando que se suelte incluso sobre plantas automáticas.

**B** = secondo DIN 3120 Forma A, con sfera in acciaio. Indicati per l'utilizzo con bussole CHROME; la sfera favorisce il montaggio e lo smontaggio della bussola.

**B** = according to DIN 3120 Form A Standard, with steel ball. Suitable for use with CHROME sockets; the ball facilitates assembly and disassembly of the socket.

**B** = selon DIN 3120 forme A, avec bille en acier. Adapté pour l'utilisation avec les douilles CHROME. La bille simplifie le montage et le démontage de la douille.

**B** = según DIN 3120 Forma A, con esfera de acero. Apto para un uso con llaves de vaso CHROME; la esfera facilita el montaje y el desmontaje de la llave tubular.

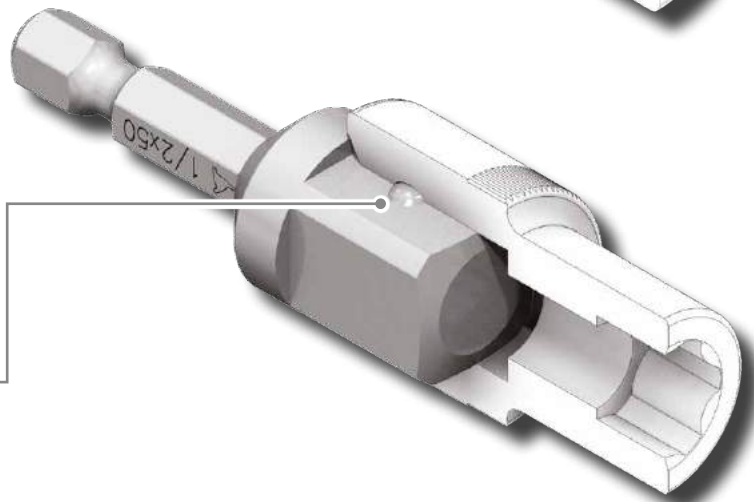
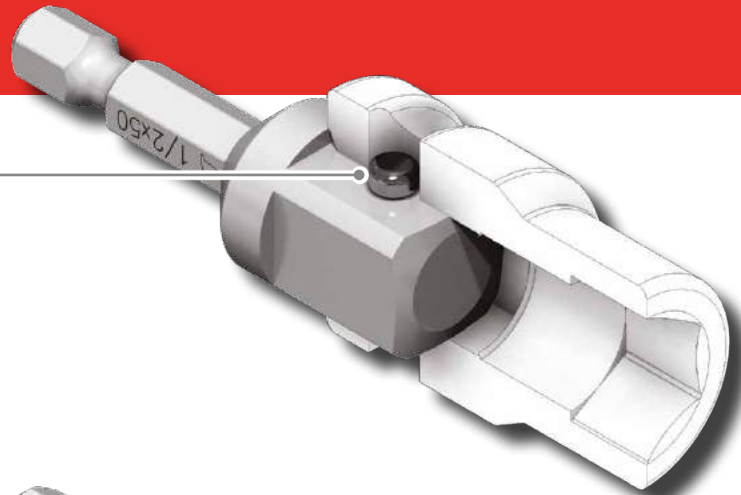

Realizzati con lo stesso acciaio di alta qualità utilizzato per gli inserti che offre un ottimo equilibrio tra durezza e tenacità.

Made with the same high-quality steel used for the bits, which provides an excellent combination of hardness and toughness.

Fabriqué avec le même acier de haute qualité utilisé pour les embouts, qui offre un excellent équilibre entre dureté et ténacité.

Fabricados con el mismo acero de alta calidad usado para las puntas, que ofrece un óptimo equilibrio entre dureza y tenacidad.



Progettati per il massimo rendimento in coppia con le bussole IMPACT e CHROME della gamma LTI.

Designed for maximum performance in combination with IMPACT and CHROME sockets from the LTI range.

Conçus pour des performances maximales en tandem avec des douilles IMPACT et CHROME de la gamme LTI.

Diseñados para el máximo rendimiento de par de torsión con llaves de vaso IMPACT y CHROME de la gama LTI.



La gamma comprende anche la versione con attacco SDS PLUS in uso sui trapani martellatori per edilizia.

The range also includes the version with SDS PLUS attachment for use on hammer drills in the construction industry.

La gamme comprend également la version avec queue SDS PLUS utilisé sur les marteaux piqueurs pour le bâtiment.

La gama también incluye la versión con empalme SDS PLUS para uso con martillos para construcción.



## 62100 ADATTATORI 1/4" C PER BUSSOLE 1/4"

ADATTATORE 1/4" C PER BUSSOLE 1/4"  
1/4" C ADAPTER FOR 1/4" SOCKETS  
ADAPTATEUR 1/4" C POUR DOUILLES 1/4"  
ADAPTADOR 1/4" C PARA VASOS DE 1/4"

**EASYPACK** | sacchetto PVC con Euro-hole • PVC bags with Euro-hole



L mm	A/B	PCS.	COD.	€ cad./each
25	B	1	62100005	2,680

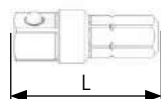

1.3



## 62101 ADATTATORI 1/4" E PER BUSSOLE 1/4"

ADATTATORE 1/4" E PER BUSSOLE 1/4"  
1/4" E ADAPTER FOR 1/4" SOCKETS  
ADAPTATEUR 1/4" E POUR DOUILLES 1/4"  
ADAPTADOR 1/4" E PARA VASOS DE 1/4"

**EASYPACK** | sacchetto PVC con Euro-hole • PVC bags with Euro-hole



L mm	A/B/C	PCS.	COD.	€ cad./each
35	A	5	62101003	9,910
50	A	5	62101005	4,020
50	B	5	62101010	4,020
75	A	1	62101025	10,200
100	A	1	62101015	10,600
100	B	1	62101020	10,600
150	A	1	62101030	29,500
200	A	1	62101035	45,600

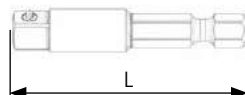

**SELPACK**  
1 pc.

L mm	A/B	COD.	€ box
50	B	62101010001	5,360





# 1.3 PORTAINSERTI/ADATTATORI

BIT HOLDERS/ADAPTERS  
PORTE EMBOUTS/ADAPTATEURS  
PORTA INSERTOS/ADAPTADORES

## 62111 ADATTATORI 1/4"E PER BUSSOLE 3/8"

ADATTATORE 1/4"E PER BUSSOLE 3/8"  
1/4"E ADAPTER FOR 3/8" SOCKETS  
ADAPTATEUR 1/4"E POUR DOUILLES 3/8"  
ADAPTADOR 1/4"E PARA VASOS DE 3/8"

**EASYPACK** | sacchetto PVC con Euro-hole • PVC bags with Euro-hole

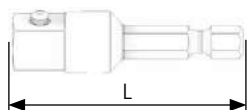

L mm	A/B	PCS.	COD.	€ cad./each
50	A	5	62111005	4,820
50	B	5	62111010	4,820
75	A	1	62111020	17,408
100	A	1	62111015	17,408
150	A	1	62111025	42,848
200	A	1	62111030	50,883



**SELPACK**  
1 pc.

L mm	A/B	COD.	€ box
50	B	6211101001	6,160

## 62121 ADATTATORI 1/4"E PER BUSSOLE 1/2"

ADATTATORE 1/4"E PER BUSSOLE 1/2"  
1/4"E ADAPTER FOR 1/2" SOCKETS  
ADAPTATEUR 1/4"E POUR DOUILLES 1/2"  
ADAPTADOR 1/4"E PARA VASOS DE 1/2"

**EASYPACK** | sacchetto PVC con Euro-hole • PVC bags with Euro-hole

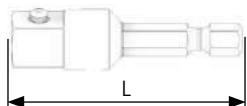

L mm	A/B	PCS.	COD.	€ cad./each
50	A	1	62121005	7,100
50	B	1	62121006	7,100



**SELPACK**  
1 pc.

L mm	A/B	COD.	€ box
50	B	62121006001	8,440

1/4"

3/8"

1/2"



## 62103 ADATTATORI SDS PLUS® PER BUSSOLE 1/4"

ADATTATORE SDS-PLUS® PER BUSSOLE 1/4"  
SDS PLUS® ADAPTER FOR 1/4" SOCKETS  
ADAPTATEUR SDS-PLUS® POUR DOUILLES 1/4"  
ADAPTADOR SDS-PLUS® PARA VASOS DE 1/4"

**EASYPACK** | sacchetto PVC con Euro-hole • PVC bags with Euro-hole

1/4"

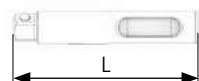

L mm	A/B	PCS.	COD.	€ cad./each
57	B	1	62103005	9,910

1.3



## 62113 ADATTATORI SDS PLUS® PER BUSSOLE 3/8"

ADATTATORE SDS-PLUS® PER BUSSOLE 3/8"  
SDS PLUS® ADAPTER FOR 3/8" SOCKETS  
ADAPTATEUR SDS-PLUS® POUR DOUILLES 3/8"  
ADAPTADOR SDS-PLUS® PARA VASOS DE 3/8"

**EASYPACK** | sacchetto PVC con Euro-hole • PVC bags with Euro-hole

3/8"

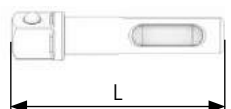

L mm	A/B	PCS.	COD.	€ cad./each
60	B	1	62113005	10,310

## 62122 ADATTATORI SDS PLUS® PER BUSSOLE 1/2"

ADATTATORE SDS-PLUS® PER BUSSOLE 1/2"  
SDS PLUS® ADAPTER FOR 1/2" SOCKETS  
ADAPTATEUR SDS-PLUS® POUR DOUILLES 1/2"  
ADAPTADOR SDS-PLUS® PARA VASOS DE 1/2"

**EASYPACK** | sacchetto PVC con Euro-hole • PVC bags with Euro-hole

1/2"

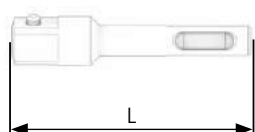

L mm	A/B	PCS.	COD.	€ cad./each
65	B	1	62122005	11,400



# 1.3 PORTAINSERTI/ADATTATORI

BIT HOLDERS/ADAPTERS  
PORTE EMBOUTS/ADAPTATEURS  
PORTA INSERTOS/ADAPTADORES

## 62102 ADATTATORI 5/16" RAPIDO PER BUSSOLE 1/4"

ADATTATORE 5/16" RAPIDO PER BUSSOLE 1/4"  
QUICK 5/16" ADAPTER FOR 1/4" SOCKETS  
ADAPTATEUR 5/16" RAPIDE POUR DOUILLES 1/4"  
ADAPTADOR 5/16" RÁPIDO PARA VASOS DE 1/4"

**EASYPACK** | sacchetto PVC con Euro-hole • PVC bags with Euro-hole

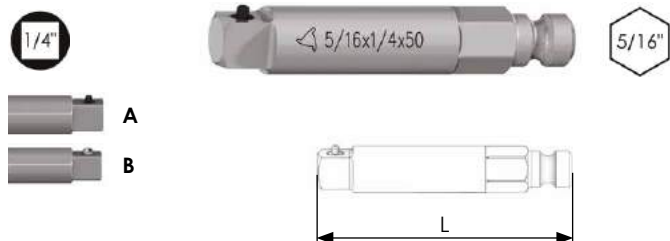

L mm	A/B	PCS.	COD.	€ cad./each
50	A	1	62102005	15,600

## 62112 ADATTATORI 5/16" RAPIDO PER BUSSOLE 3/8"

ADATTATORE 5/16" RAPIDO PER BUSSOLE 3/8"  
QUICK 5/16" ADAPTER FOR 3/8" SOCKETS  
ADAPTATEUR 5/16" RAPIDE POUR DOUILLES 3/8"  
ADAPTADOR 5/16" RÁPIDO PARA VASOS DE 3/8"

**EASYPACK** | sacchetto PVC con Euro-hole • PVC bags with Euro-hole

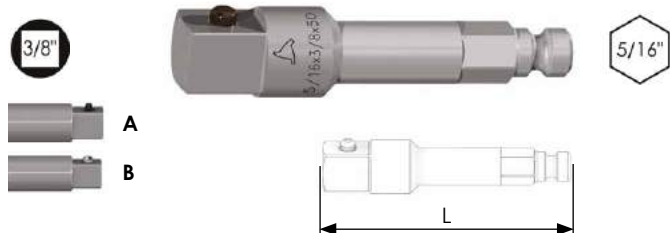

L mm	A/B	PCS.	COD.	€ cad./each
50	A	1	62112005	30,128

## 62114 ADATTATORI 7/16" RAPIDO PER BUSSOLE 3/8"

ADATTATORE 7/16" RAPIDO PER BUSSOLE 3/8"  
QUICK 7/16" ADAPTER FOR 3/8" SOCKETS  
ADAPTATEUR 7/16" RAPIDE POUR DOUILLES 3/8"  
ADAPTADOR 7/16" RÁPIDO PARA VASOS DE 3/8"

**EASYPACK** | sacchetto PVC con Euro-hole • PVC bags with Euro-hole



L mm	A/B	PCS.	COD.	€ cad./each
70	A	1	62114005	26,513

1/4"

3/8"

1/2"

**62601****ASSORTIMENTO 3 ADATTATORI**

ASSORTIMENTO 3 ADATTATORI PER BUSSOLE 1/4", 3/8" E 1/2"  
 3 PCS. ADAPTERS SET FOR 1/4", 3/8" AND 1/2" SOCKETS  
 JEU DE 3 ADAPTATEURS POUR DOUILLES 1/4", 3/8" ET 1/2"  
 JUEGO 3 ADAPTADORES PARA VASOS DE 1/4", 3/8" Y 1/2"

**EASYPACK** | sacchetto PVC con Euro-hole • PVC bags with Euro-hole

1/4"

3/8"

1/2"

1/4"  
E

A/B	PCS.	COD.	€ cad./each
B	1	62601001	6,600



95 X 145 mm

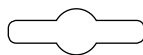

EURO-HOLE

1.3

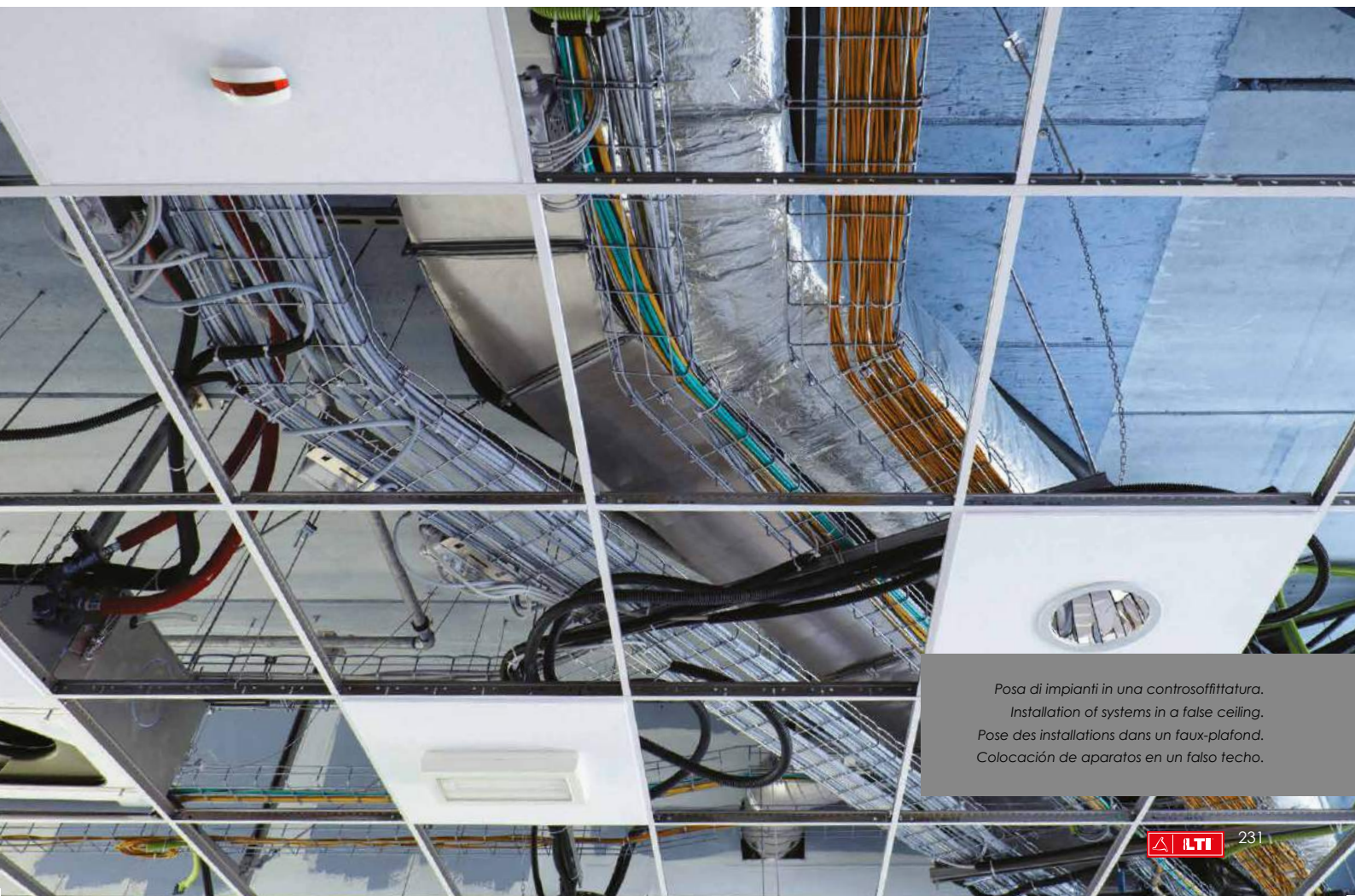

Posa di impianti in una controsoffittatura.  
 Installation of systems in a false ceiling.  
 Pose des installations dans un faux-plafond.  
 Colocación de aparatos en un falso techo.



# 1.3 PORTAINSERTI/ADATTATORI

BIT HOLDERS/ADAPTERS  
PORTE EMBOUTS/ADAPTATEURS  
PORTA INSERTOS/ADAPTADORES

65011

## MAGNETIZZATORI SMAGNETIZZATORI

BLOCCHETTO MAGNETIZZATORE / SMAGNETIZZATORE PER GIRAVITE  
MAGNETIZER / DEMAGNETIZER FOR SCREWDRIVERS  
MAGNÉTISEUR/DÉMAGNÉTISEUR POUR TOURNEVIS  
BLOQUETE DE MAGNETIZACIÓN / DESMAGNETIZACIÓN PARA DESTORNILLADORES

EASYPACK | sacchetto PVC con Euro-hole • PVC bags with Euro-hole

L mm	ℓ mm	PCS.	COD.	€ cad./each
54	49	1	65011005	9,910



### FOCUS ON



Ideale per magnetizzare temporaneamente giravite e lame di avvitatura. Inserire la punta nell'apposita fessura per alcuni secondi. Per smagnetizzare inserire la punta nell'altra fessura.

Ideal to temporarily magnetize screwdrivers and screwing blades. Insert the tip into the slot for a few seconds. To demagnetize, insert the tip into the other slot.

Idéal pour magnétiser temporairement les tournevis et les lames de vissage. Insérer la pointe dans la fente spéciale pendant quelques secondes. Pour démagnétiser, insérer la pointe dans l'autre fente.

Ideal para magnetizar temporalmente destornilladores y lamas de atornillado. Introducir la punta en la debida ranura por unos segundos. Para desmagnetizar introducir la punta en la otra ranura.



65011

## BUSSOLE MAGNETICHE PER LAME O GIRAVITE

BUSOLA MAGNETICA EXTRA-FORTE PER GIRAVITE E LAME  
EXTRA-STRONG MAGNETIC SOCKET FOR SCREWDRIVERS AND POWER BITS  
DOUILLE MAGNÉTIQUE EXTRA-FORTE POUR TOURNEVIS ET EMBOUTS  
VASO MAGNÉTICO EXTRA-FUERTE PARA DESTORNILLADORES Y PUNTAS

EASYPACK | sacchetto PVC con Euro-hole • PVC bags with Euro-hole

L mm	Ø mm	PCS.	COD.	€ cad./each
27	16	1	65011010	8,440

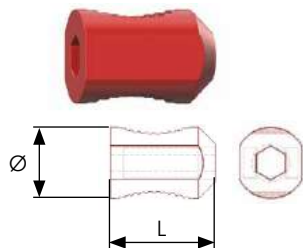

70 X 120 mm



### FOCUS ON

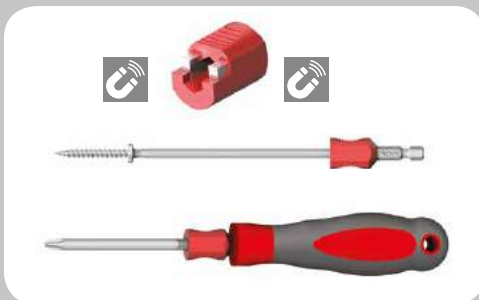

Diametro foro 7mm, doppio magnete, trattenimento fino a 400 gr. Agisce anche a 12cm dalla vite. Si consiglia di forzare la bussola sull'attacco esagonale per assicurarne la posizione. Indicato anche per giravite con lama fino a diametro 7.

Hole diameter of 7 mm, two magnets, retention up to 400 g. Also acts at a distance of up to 12cm from the screw. Recommended for mounting the socket onto the hexagon attachment to ensure its position. Suitable also for screwdrivers with minimum blade diameter of 7.

Diamètre du trou 7 mm, double aimant, rétention jusqu'à 400 grammes. Il agit également à 12cm de la vis. Nous recommandons de forcer la douille sur le raccord hexagonal pour assurer sa position. Convient aussi pour les tournevis avec lame jusqu'à 7 mm de diamètre.

Diámetro orificio de 7mm, doble imán, retención de hasta 400gr. También actúa a 12cm del tornillo. Se aconseja forzar la llave tubular sobre el empalme hexagonal para asegurar la posición. También es apto para destornilladores con lama hasta un diámetro de 7.







# 65011 PINZA PORTA-VITE PER VITI INOX

PINZA PORTA-VITE PER VITI INOX  
SCREW HOLDER FOR STAINLESS STEEL SCREWS  
PINCE PORTE-VIS POUR VIS INOXYDABLE  
PINZA PORTATORNILLAS PARA TORNILLOS DE ACERO INOXIDABLES

**NEW!**

**EASYPACK** | sacchetto PVC con Euro-hole • PVC bags with Euro-hole



Ø	PCS.	COD.	€ cad./each
10	1	65011020	1,800



## FOCUS ON



Applicata sul portainseriti permette di trattenere sull'inserto viti che non possono essere trattentute da sistemi magnetici.

Applied on the bit holder it allows to retain on the insert screws that cannot be retained by magnetic systems.

Appliqué sur le porte-embout, il permet de retenir sur l'embout des vis qui ne peuvent pas être retenues par les systèmes magnétiques.

Aplicado sobre el portapuntas, permite retener sobre la punta tornillos que no sostenerse mediante sistemas magnéticos.



1.3



# 66037 **FastOut** SET ESTRATTORI PER VITI

ASSORTIMENTO 4 PCS. ESTRATTORI PER VITI DANNEGGIATE  
SET OF 4 EXTRACTORS FOR DAMAGED SCREWS  
JEU 4 PIÈCES D'EXTRACTEURS POUR VIS ABIMÉES  
JUEGO DE 4 PIEZAS DE EXTRACTORES PARA TORNILLOS DAÑADOS

**NEW!**

4  
pcs.

COD. **66037010**  
€ 15,200

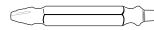

No. 4 - No. 7 1pc.	No. 8 - No. 10 1pc.	No. 11 - No. 14 1pc.	No. 16 - No. 24 1pc.
-----------------------	------------------------	-------------------------	-------------------------



*Il capitolo 2 è dedicato alle tipologie di inserti più speciali ed indicati per campi di applicazione particolari come il settore industriale, quello meccanico o dell'elettronica. In questi ambiti vengono infatti richiesti anche inserti ed accessori con attacchi differenti da quello presentato nel primo capitolo.*

*Il reparto di produzione interno, dotato di moderne macchine per la lavorazione ed il trattamento termico, ci permette inoltre di studiare e realizzare utensili secondo le specifiche indicate dal cliente stesso. Sono ormai migliaia i codici di inserti ed accessori speciali che abbiamo fabbricato per clienti di tutto il mondo.*

*Chapter 2 is devoted to specific types of bits, manufactured expressly for special applications in the industrial, mechanical, electronic or precision sectors. In fact, these sectors require bits and accessories with attachments and tips different from those presented in the first chapter. Our internal production department, equipped with modern machinery for machining and heat treatments, allows us to design and create tools according to customer specifications. We produce thousands of special bits and accessories for our customers around the world.*

*Le chapitre 2 est consacré aux types d'embouts plus spécifiques, expressément conçus pour des champs d'application uniques comme le secteur industriel, mécanique ou de l'électronique ou de précision. Ces domaines requièrent en effet des embouts et des accessoires avec des raccords et des empreintes différents de ceux présentés dans le premier chapitre.*

*Notre atelier de production interne, équipé de machines modernes pour l'usinage et le traitement thermique, nous permet d'étudier et de réaliser des outils selon les spécificités indiquées par le client. Les codes d'embouts et d'accessoires spéciaux que nous construisons pour nos clients du monde entier sont des milliers.*

*El capítulo 2 está dedicado a los tipos de puntas más específicos, especialmente fabricados para campos de aplicación únicos, como el sector industrial, el mecánico o el de la electrónica o de precisión. En estos ámbitos se necesitan puntas y accesorios con empalmes y huellas diferentes de los que se han presentado en el primer apartad.*

*Nuestro departamento de producción interno, provisto de modernas máquinas para la elaboración y el tratamiento térmico, nos permite estudiar y realizar utensilios siguiendo las especificaciones indicadas por el cliente. Son miles los códigos de puntas y de accesorios especiales que fabricamos para nuestros clientes de todo el mundo.*



# 2

## INSERTI E CHIAVI SPECIALI SPECIAL BITS AND SETTERS EMBOUTS ET CLÉS SPÉCIALES PUNTAS Y VASOS ESPECIALES

### INSERTI SPECIALI

SPECIAL BITS - EMBOUTS SPÉCIALES - PUNTAS ESPECIALES



	<b>INSERTI 10mm (3/8")</b> 10mm (3/8") BITS • EMBOUTS 10mm (3/8") • PUNTAS 10mm (3/8")	p. 238
	<b>INSERTI 5/16" C</b> 5/16" C BITS • EMBOUTS 5/16" C • PUNTAS 5/16" C	p. 244
	<b>INSERTI 4mm</b> 4mm BITS • EMBOUTS 4mm • PUNTAS 4mm	p. 249
	<b>INSERTI 4MA</b> 4MA BITS • EMBOUTS 4MA • PUNTAS 4MA	p. 256
	<b>INSERTI 5MA</b> 5MA BITS • EMBOUTS 5MA • PUNTAS 5MA	p. 258
	<b>INSERTI 6MA</b> 6MA BITS • EMBOUTS 6MA • PUNTAS 6MA	p. 260
	<b>INSERTI 10x32 UNF</b> 10x32 UNF BITS • EMBOUTS 10x32 UNF • PUNTAS 10x32 UNF	p. 262
	<b>INSERTI 3/16x32</b> 3/16x32 BITS • EMBOUTS 3/16x32 • PUNTAS 3/16x32	p. 264
	<b>LAME 7/16" RAPIDO</b> 7/16" QUICK POWER BITS • EMBOUTS 7/16" RAPIDE • PUNTAS DE 7/16" RÁPIDO	p. 265
	<b>LAME 5/16" RAPIDO</b> 5/16" QUICK POWER BITS • EMBOUTS 5/16" RAPIDE • PUNTAS DE 5/16" RÁPIDO	p. 266
	<b>LAME 3mm</b> 3mm POWER BITS • EMBOUTS 3mm • PUNTAS 3mm	p. 268
	<b>LAME A SPINA</b> TROUGH HOLE POWER BITS • EMBOUTS TRAVERSANTES • PUNTAS AGUJERO PASANTE	p. 268

### INSERTI DOPPI D.7mm

	<b>INSERTI DOPPI D.7mm</b> D.7mm DOUBLE • DOUPLES D.7mm • DOBLES D.7mm	p. 269
---	---	--------

### CHIAVI SPECIALI

SPECIAL SETTERS - CLÉS SPÉCIALES - VASOS ESPECIALES

	<b>CHIAVI AVVITABUSSOLE</b> SCREW-IN TOOL FOR COUPLING SLEEVE • CLÉ POUR DOUILLES FILETÉES • ADAPTADOR PARA VASOS ROSCADOS	p. 270
	<b>CHIAVI AVVITAPRIGIONIERI</b> INTERNAL TRHEAD INSERTION TOOL • CLÉS À FILETAGE INTERNE POUR TIGES FILETÉES • LLAVES CON ROSCA INTERIOR PARA ESPARRÁGOS	p. 271
	<b>CHIAVI PORTA PUNTE/MASCHI</b> DRILL/TAP SETTERS • CLÉS PORTE-FORETS/TARAUDS • LLAVES PORTA PUNTAS/MACHOS	p. 272
	<b>CHIAVI PER CERNIERE ANUBA</b> KEY-LOCKS FOR ANUBA HINGENS • CLÉS POUR CHARNIERES ANUBA • LLAVES PARA BISAGRAS ANUBA	p. 273
	<b>CHIAVI PORTAMANDRINI</b> CHUCK ADAPTERS • CLÉS PORTE-MANDRINS • LLAVES PORTA MANDRILES	p. 274
	<b>SDS-MAX/SDS-PLUS</b>	p. 275
	<b>RINVIO PER TRAPANI</b> ANGLE DRIVER FOR DRILLS • RENVOI D'ANGLE POUR PERCEUSES • ANGULAR PARA TALADROS	p. 275



# SPECIALI

## INSERTI E CHIAVI SPECIALI PER L'INDUSTRIA, L'AUTOMAZIONE E LA MANUTENZIONE

*Special bits and setters for the industrial, automation and maintenance sectors.*

*Embouts et clés spéciales pour le secteur de l'industrie, de l'automatisation industrielle et de la maintenance.*

*Puntas y llaves especiales para el sector de la industria, de la automatización industrial y del mantenimiento.*

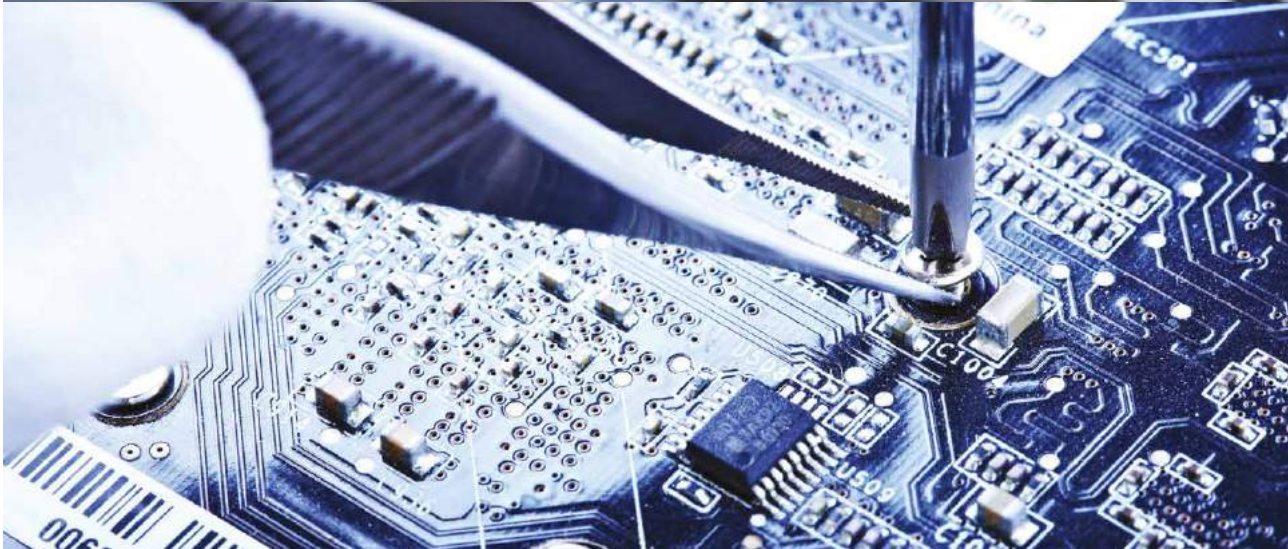

1

Nel campo meccanico, per la produzione e riparazione di motori, e nella cantieristica, ambiti nei quali è necessario l'uso di fasteners di diametri elevati e a massime prestazioni, vengono utilizzati inserti con attacco maggiorato ed impronte a 6 e 12 lobi che permettano una migliore distribuzione della coppia di serraggio. Un appropriato acciaio al Cromo Silicio Vanadio garantisce una elevata resistenza ed una maggiore elasticità.

*Bits with larger attachments and tips with 6 and 12 lobes, which provide better distribution of the tightening torque, are commonly used in the mechanical industry for the production and repair of engines, and in shipbuilding yards. These areas require the use of fasteners with wide diameters and high performances. Chrome-silicon-vanadium steel guarantees high resistance and greater elasticity.*

*Dans le domaine de la mécanique, pour la production et la réparation des moteurs et dans l'industrie de la construction navale, domaines dans lesquels l'utilisation de fixations avec des diamètres élevés à haute performance est nécessaire, nous utilisons des embouts avec des raccords majorés et des empreintes à 6 et 12 lobes qui permettent une meilleure distribution du couple de serrage. Un acier approprié au chrome-silicium-vanadium garantit une résistance élevée et une plus grande élasticité.*

*En el campo de la mecánica, para la producción y reparación de motores, y en los astilleros, ámbitos en los cuales es necesario el uso de elementos de sujeción de grandes diámetros y de elevadas prestaciones, se usan puntas con empalmes aumentados y huellas de 6 a 12 lóbulos que permitan una mejor distribución de la par de torsión de cierre. Un apropiado acero al Cromo Silicio Vanadio garantiza una elevada resistencia y una mayor elasticidad.*

2

I dispositivi elettronici sono ormai nelle mani di tutti e, con loro, le micro viti sono largamente diffuse. Prerogativa di questo tipo di fasteners è l'estrema precisione: è molto facile rovinare l'impronta o il filetto. Per questo tipo di applicazioni abbiamo selezionato una serie di inserti con le impronte più comuni, realizzati con un acciaio apposito, estremamente tenace, per evitare deformazioni del l'impronta che possano danneggiare la cava della vite.

*Suitable for the production of electronic devices where micro-screws are widely used. The special feature of this type of fastener is its extreme precision: it is very easy to ruin the tip or thread. For these types of applications, we selected a series of bits with more common tips, made with special, extremely strong, steel to prevent deformations of the tip that might damage the slot of the screw.*

*Dans le domaine des appareils électroniques où les micro-vis sont largement diffusées, la précision extrême est la prérogative de ce type de fixation. Il est très facile d'abîmer l'empreinte ou le filetage. Pour ce type d'application, nous avons sélectionné un certain nombre d'embouts avec les empreintes les plus communes, réalisés à l'aide d'un acier spécial, extrêmement tenace, afin d'éviter toute déformation de l'empreinte, qui pourrait endommager la fente de la vis.*

*En el campo de los dispositivos electrónicos donde los micro tornillos son muy difundidos. Prerogativa de este tipo de sujeción es la extrema precisión: es muy fácil estropear la huella y la rosca. Para este tipo de aplicación hemos seleccionado una serie de puntas con las huellas más comunes, realizadas con el acero indicado, extremadamente tenaz, para evitar deformaciones de la huella que puedan dañar la ranura del tornillo.*

3

La produzione di utensili per applicazioni industriali e per impianti di assemblaggio automatizzati è sicuramente un settore nel quale il marchio LTI si è da sempre contraddistinto. Grazie a questa nostra specificità, da sempre apprezzata dai nostri clienti, ogni due giorni introduciamo un nuovo codice prodotto. Abbiamo quindi selezionato una gamma di utensili industriali sempre disponibili a magazzino e con un prezzo di listino fisso a prescindere dalla quantità, ponendo la massima attenzione alla qualità per garantire la massima affidabilità.

*The LTI brand has always been a pioneer in the production of tools for industrial applications and for automated assembly systems. For this case, we also offer a range of industrial tools that are always in stock, placing maximum attention on the construction to guarantee maximum reliability.*

*La production d'outils pour applications industrielles et installations d'assemblage automatisées est sans aucun doute un des secteurs dans lequel la marque LTI s'est depuis toujours distinguée. Nous avons sélectionné également dans ce cas, une gamme d'outils industriels toujours en stock, en accordant une attention maximum dans la construction pour garantir une fiabilité maximum.*

*La producción de utensilios para aplicaciones industriales y para plantas de ensamblaje automatizadas es seguramente uno de los sectores en el cual la marca LTI ha destacado desde siempre. También en este caso hemos seleccionado una gama de utensilios industriales siempre disponibles en almacén, prestando la máxima atención a la fabricación para garantizar la máxima fiabilidad.*

2





# 2 INSERTI E CHIAVI SPECIALI

BITS AND SPECIAL SETTERS  
EMBOUS ET CLÉS SPÉCIALES  
PUNTAS Y VASOS ESPECIALES

## 61011 ESAGONO 10mm (3/8")

INSERTI 10mm (3/8") ESAGONALI PER MECCANICA  
10mm (3/8") HEX BITS FOR MECHANICS  
EMBOUS 10 mm (3/8 ") 6 PANS POUR MÉCANIQUE  
PUNTAS DE 10mm (3/8") HEXAGONALES PARA MECÁNICA

56/58 HRC

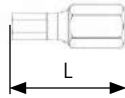

**EASYPACK** | sacchetto PVC con Euro-hole • PVC bags with Euro-hole

Ø	L mm	PCS.	COD.	€ cad./each
4	30	5	61011005	1,720
	75	5	61011010	2,990
5	30	5	61011015	1,720
	75	5	61011020	2,990
6	30	5	61011025	1,720
	75	5	61011030	2,990
7	30	5	61011035	1,720
	75	5	61011040	2,990
8	30	5	61011045	1,720
	75	5	61011050	2,990
10	30	5	61011055	1,720
	75	5	61011060	2,990
12	30	5	61011065	2,190
	75	5	61011070	3,650
14	30	5	61011075	2,550
	75	5	61011080	3,810

## 61129 XZN - 10mm (3/8")

INSERTI 10mm (3/8") PER VITI XZN PER MECCANICA  
10mm (3/8") BITS FOR XZN MECHANICAL SCREWS  
EMBOUS 10 mm (3/8 ") POUR VIS XZN POUR MÉCANIQUE  
PUNTAS DE 10mm (3/8") PARA TORNILLOS XZN PARA MECÁNICA

56/58 HRC

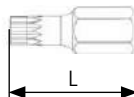

**EASYPACK** | sacchetto PVC con Euro-hole • PVC bags with Euro-hole

Ø	L mm	PCS.	COD.	€ cad./each
M5	30	5	61129005	2,010
	75	5	61129010	3,220
M6	30	5	61129015	2,010
	75	5	61129020	3,220
M8	30	5	61129025	2,010
	75	5	61129030	3,220
M10	30	5	61129035	2,010
	75	5	61129040	3,220
M12	30	5	61129045	2,410
	75	5	61129050	3,890
M14	30	5	61129055	2,820
	75	5	61129060	4,290



## 61100 TX - 10mm (3/8")

INSERTI 10mm (3/8") PER VITI TORX® PER MECCANICA  
10mm (3/8") BITS FOR TORX® MECHANICAL SCREWS  
EMBOUS 10 mm (3/8 ") POUR VIS TORX® POUR MÉCANIQUE  
PUNTAS DE 10mm (3/8") PARA TORNILLOS TORX® PARA MECÁNICA

56/58 HRC

EASYPACK | sacchetto PVC con Euro-hole • PVC bags with Euro-hole

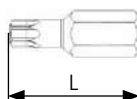

	L mm	PCS.	COD.	€ cad./each
TX10	30	5	61100005	1,750
	75	5	61100010	2,950
TX15	30	5	61100015	1,750
	75	5	61100020	2,950
TX20	30	5	61100025	1,750
	75	5	61100030	2,950
TX25	30	5	61100035	1,750
	75	5	61100040	2,950
TX27	30	5	61100045	1,750
	75	5	61100050	2,950
TX30	30	5	61100055	1,750
	75	5	61100060	2,950
TX40	30	5	61100065	1,750
	75	5	61100070	2,950
TX45	30	5	61100075	1,750
	75	5	61100080	2,950
TX50	30	5	61100085	1,750
	75	5	61100090	2,950
TX55	30	5	61100095	1,750
	75	5	61100100	2,950

## 61114 TXH CON FORO 10mm (3/8")

INSERTI 10mm (3/8") PER VITI TORX® CON FORO PER MECCANICA  
10mm (3/8") BITS FOR TORX® MECHANICAL SCREWS  
EMBOUS 10 mm (3/8 ") POUR VIS TORX® AVEC TROU POUR MÉCANIQUE  
PUNTAS DE 10mm (3/8") PARA TORNILLOS TORX® CON ORIFICIO PARA MECÁNICA

56/58 HRC

EASYPACK | sacchetto PVC con Euro-hole • PVC bags with Euro-hole

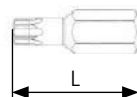

	L mm	PCS.	COD.	€ cad./each
TXH10	30	5	61114005	2,280
	75	5	61114010	3,490
TXH15	30	5	61114015	2,280
	75	5	61114020	3,490
TXH20	30	5	61114025	2,280
	75	5	61114030	3,490
TXH25	30	5	61114035	2,280
	75	5	61114040	3,490
TXH27	30	5	61114045	2,280
	75	5	61114050	3,490
TXH30	30	5	61114055	2,280
	75	5	61114060	3,490
TXH40	30	5	61114065	2,280
	75	5	61114070	3,490
TXH45	30	5	61114075	2,280
	75	5	61114080	3,490
TXH50	30	5	61114085	2,280
	75	5	61114090	3,490
TXH55	30	5	61114095	2,280
	75	5	61114100	3,490





# 2 INSERTI E CHIAVI SPECIALI

BITS AND SPECIAL SETTERS  
EMBOUS ET CLÉS SPÉCIALES  
PUNTAS Y VASOS ESPECIALES

## 61128 RIBE - 10mm (3/8")

INSERTI 10mm (3/8") PER VITI RIBE® PER MECCANICA  
10mm (3/8") BITS FOR RIBE® MECHANICAL SCREWS  
EMBOUS 10 mm (3/8 ") POUR VIS RIBE® POUR MÉCANIQUE  
PUNTAS DE 10mm (3/8") PARA TORNILLOS RIBE® PARA MECÁNICA

56/58 HRC

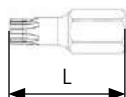

**EASYPACK** | sacchetto PVC con Euro-hole • PVC bags with Euro-hole

	L mm	PCS.	COD.	€ cad./each
<b>M4</b>	30	5	61128005	2,010
	75	5	61128010	3,220
<b>M5</b>	30	5	61128015	2,010
	75	5	61128020	3,220
<b>M6</b>	30	5	61128025	2,010
	75	5	61128030	3,220
<b>M7</b>	30	5	61128035	2,010
	75	5	61128040	3,220
<b>M8</b>	30	5	61128045	2,010
	75	5	61128050	3,220
<b>M9</b>	30	5	61128055	2,010
	75	5	61128060	3,220
<b>M10</b>	30	5	61128065	2,010
	75	5	61128070	3,220
<b>M12</b>	30	5	61128075	2,410
	75	5	61128080	3,890
<b>M13</b>	30	5	61128085	2,410
	75	5	61128090	3,890
<b>M14</b>	30	5	61128095	2,820
	75	5	61128100	4,290
<b>M16</b>	30	5	61128105	3,220
	75	5	61128110	6,430

## 61127 RIBE H - 10mm (3/8")

INSERTI 10mm (3/8") PER VITI RIBE® CON FORO PER MECCANICA  
10mm (3/8") BITS FOR RIBE® MECHANICAL SCREWS WITH HOLE  
EMBOUS 10 mm (3/8 ") POUR VIS RIBE® AVEC TROU POUR MÉCANIQUE  
PUNTAS DE 10mm (3/8") PARA TORNILLOS RIBE® CON ORIFICIO PARA MECÁNICA

56/58 HRC

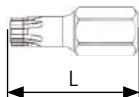

**EASYPACK** | sacchetto PVC con Euro-hole • PVC bags with Euro-hole

	L mm	PCS.	COD.	€ cad./each
<b>MH5</b>	30	5	61127005	2,550
	75	5	61127010	3,890
<b>MH6</b>	30	5	61127015	2,550
	75	5	61127020	3,890
<b>MH7</b>	30	5	61127025	2,550
	75	5	61127030	3,890
<b>MH8</b>	30	5	61127035	2,550
	75	5	61127040	3,890
<b>MH9</b>	30	5	61127045	2,550
	75	5	61127050	3,890
<b>MH10</b>	30	5	61127055	2,550
	75	5	61127060	3,890
<b>MH12</b>	30	5	61127065	2,950
	75	5	61127070	4,560





## 62081 PORTAINSERTI 3/8" CON SFERA

PORTAINSERTI 3/8" CON SFERA PER INSERTI 10mm  
3/8" BIT-HOLDER WITH BALL FOR 10mm BITS  
PORTE-EMBOUTS 3/8" AVEC BILLE POUR EMBOUTS 10mm  
PORTA PUNTAS 3/8" CON ESFERA PARA PUNTAS 10mm

**EASYPACK** | sacchetto PVC con Euro-hole • PVC bags with Euro-hole

L mm	Ø mm	PCS.	COD.	€ cad./each
30	17	1	62081005	3,890

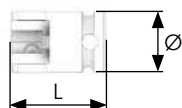

## 62082 PORTAINSERTI 3/8" SNODATO

PORTAINSERTI SNODATO CON BLOCCO 3/8" PER INSERTI 10mm  
ARTICULATED 3/8" BIT HOLDER WITH LOCK FOR 10mm BITS  
PORTE-EMBOUTS 3/8" ARTICULÉ AVEC BLOCCAGE POUR EMBOUTS 10mm  
PORTA PUNTAS 3/8" CON ARTICULACIÓN Y BLOQUEO PARA PUNTAS 10mm

**EASYPACK** | sacchetto PVC con Euro-hole • PVC bags with Euro-hole

L mm	Ø mm	PCS.	COD.	€ cad./each
90	25	1	62082005	28,200

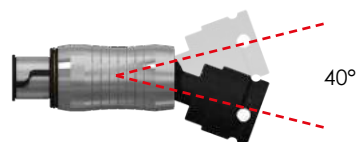
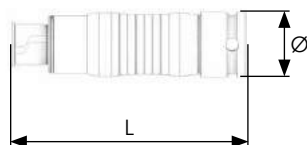

2



## 62083 PORTAINSERTI 1/2" CON SFERA

PORTAINSERTI 1/2" CON SFERA PER INSERTI 10mm  
1/2" BIT-HOLDER WITH BALL FOR 10mm BITS  
PORTE-EMBOUTS 1/2" AVEC BILLE POUR EMBOUTS 10mm  
PORTA PUNTAS 1/2" CON ESFERA PARA PUNTAS 10mm

**EASYPACK** | sacchetto PVC con Euro-hole • PVC bags with Euro-hole

L mm	Ø mm	PCS.	COD.	€ cad./each
36	22	1	62083005	5,090

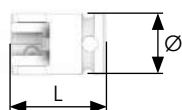



# 2 INSERTI E CHIAVI SPECIALI

BITS AND SPECIAL SETTERS  
EMBOUTS ET CLÉS SPÉCIALES  
PUNTAS Y VASOS ESPECIALES

## 66013 ASSORTIMENTI INSERTI 10mm (3/8") TX/TXH

ASSORTIMENTO 22 PCS. INSERTI 10mm (3/8")  
SET OF 22 BITS 10mm (3/8")  
JEU DE 22 PIÈCES EMBOUTS 10 mm (3/8")  
JUEGO DE 22 PIEZAS PUNTAS 10mm (3/8")



22 pcs.

282 X 35 X 130 mm

COD. **66013005**  
€ 52,600

61100x30mm

TX10	TX15	TX20	TX25	TX27	TX30	TX40	TX45	TX50	TX55
1pc.	1pc.	1pc.	1pc.	1pc.	1pc.	1pc.	1pc.	1pc.	1pc.

61100x75mm

TX10	TX15	TX20	TX25	TX27	TX30	TX40	TX45	TX50	TX55
1pc.	1pc.	1pc.	1pc.	1pc.	1pc.	1pc.	1pc.	1pc.	1pc.

COD. **66013010**  
€ 62,200

61114x30mm

TXH10	TXH15	TXH20	TXH25	TXH27	TXH30	TXH40	TXH45	TXH50	TXH55
1pc.	1pc.	1pc.	1pc.	1pc.	1pc.	1pc.	1pc.	1pc.	1pc.

61114x75mm

TXH10	TXH15	TXH20	TXH25	TXH27	TXH30	TXH40	TXH45	TXH50	TXH55
1pc.	1pc.	1pc.	1pc.	1pc.	1pc.	1pc.	1pc.	1pc.	1pc.

INCLUSO / INCLUDED / INCLUSE / INCLUIDO

COD. 62081005



COD. 62083005



## 66013 ASSORTIMENTI INSERTI 10mm (3/8") RIBE

ASSORTIMENTO 20 PCS. INSERTI 10mm (3/8")  
SET OF 20 BITS 10mm (3/8")  
JEU DE 20 PIÈCES EMBOUTS 10 mm (3/8")  
JUEGO DE 20 PIEZAS PUNTAS 10mm (3/8")



20 pcs.

282 X 35 X 130 mm

COD. **66013015**  
€ 61,000

61128x30mm

M6	M7	M8	M9	M10	M12	M13	M14	M16
1pc.	1pc.	1pc.	1pc.	1pc.	1pc.	1pc.	1pc.	1pc.

61128x75mm

M6	M7	M8	M9	M10	M12	M13	M14	M16
1pc.	1pc.	1pc.	1pc.	1pc.	1pc.	1pc.	1pc.	1pc.

INCLUSO / INCLUDED / INCLUSE / INCLUIDO

COD. 62081005



COD. 62083005





**66013**

# ASSORTIMENTI INSERTI 10mm (3/8")

ASSORTIMENTO 40 PCS. INSERTI 10mm (3/8")  
SET OF 40 BITS 10mm (3/8")  
JEU DE 40 PIÈCES EMBOUTS 10 mm (3/8")  
JUEGO DE 40 PIEZAS PUNTAS 10mm (3/8")



40  
pcs.

320 X 35 X 150 mm

COD. **66013016**

€ 87,500

61100x30mm

TX20	TX25	TX30	TX40	TX45	TX50	TX55
1pc.	1pc.	1pc.	1pc.	1pc.	1pc.	1pc.

61128x30mm

M5	M6	M7	M8	M9	M10	M12
1pc.	1pc.	1pc.	1pc.	1pc.	1pc.	1pc.

61129x30mm

M5	M6	M8	M10	M12
1pc.	1pc.	1pc.	1pc.	1pc.

61100x75mm

TX20	TX25	TX30	TX40	TX45	TX50	TX55
1pc.	1pc.	1pc.	1pc.	1pc.	1pc.	1pc.

61128x75mm

M5	M6	M7	M8	M9	M10	M12
1pc.	1pc.	1pc.	1pc.	1pc.	1pc.	1pc.

61129x75mm

M5	M6	M8	M10	M12
1pc.	1pc.	1pc.	1pc.	1pc.

INCLUSO / INCLUDED / INCLUSE / INCLUIDO

COD. 62081005



COD. 62083005



2





# 2 INSERTI E CHIAVI SPECIALI

BITS AND SPECIAL SETTERS  
EMBOUS ET CLÉS SPÉCIALES  
PUNTAS Y VASOS ESPECIALES

**61053** PH - 5/16" C

INSERTI 5/16" C (C8) PHILLIPS® PER MECCANICA E CARPENTERIA  
PHILLIPS® 5/16" C (C8) BITS FOR MECHANICAL AND STRUCTURAL WORKS  
EMBOUS 5/16" C (C8) PHILLIPS® POUR MÉCANIQUE ET CHARPENTERIE  
PUNTAS DE 5/16" C (C8) PHILLIPS® PARA MECÁNICA Y CONSTRUCCIÓN

56/58 HRC

**EASYPACK** | sacchetto PVC con Euro-hole • PVC bags with Euro-hole

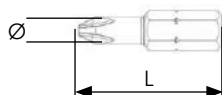

+	L mm	Ø mm	PCS.	COD.	€ cad./each
PH1	32	4,5	5	61053005	2,090
PH2	32	6	5	61053010	2,090
PH3	32	5/16	5	61053015	2,090
PH4	38	10	5	61053020	2,090

**61077** PZ - 5/16" C

INSERTI 5/16" C (C8) POZIDRIV® PER MECCANICA E CARPENTERIA  
POZIDRIV® 5/16" C (C8) BITS FOR MECHANICAL AND STRUCTURAL WORKS  
EMBOUS 5/16" C (C8) POZIDRIV® POUR MÉCANIQUE ET CHARPENTERIE  
PUNTAS DE 5/16" C (C8) POZIDRIV® PARA MECÁNICA Y CONSTRUCCIÓN

56/58 HRC

**EASYPACK** | sacchetto PVC con Euro-hole • PVC bags with Euro-hole



+	L mm	Ø mm	PCS.	COD.	€ cad./each
PZ1	32	4,5	5	61077005	2,090
PZ2	32	6	5	61077010	2,090
PZ3	32	5/16	5	61077015	2,090
PZ4	38	10	5	61077020	2,090



## 61024 TAGLIO - 5/16" C

INSERTI 5/16" C (C8) A TAGLIO PER MECCANICA E CARPENTERIA  
5/16" C (C8) SLOTTED BITS FOR MECHANICAL AND STRUCTURAL WORKS  
EMBOUTS 5/16" C (C8) À FENTE POUR MÉCANIQUE ET CHARPENTERIE  
PUNTAS DE 5/16" C (C8) DE CORTE PARA MECÁNICA Y CONSTRUCCIÓN

56/58 HRC

**EASYPACK** | sacchetto PVC con Euro-hole • PVC bags with Euro-hole



Ø mm	L mm	PCS.	COD.	€ cad./each	
1	6,5	41	5	61024005	2,870
1,2	7	41	5	61024010	2,870
1,2	8	41	5	61024015	2,870
1,6	10	41	5	61024020	3,570
2	13	41	5	61024025	4,820

## 61008 ESAGONO - 5/16" C

INSERTI 5/16" C (C8) ESAGONALI PER MECCANICA E CARPENTERIA  
5/16" C (C8) HEX BITS FOR MECHANICAL AND STRUCTURAL WORKS  
EMBOUTS 5/16" C (C8) 6 PANS POUR MÉCANIQUE ET CHARPENTERIE  
PUNTAS DE 5/16" C (C8) HEXAGONALES PARA MECÁNICA Y CONSTRUCCIÓN

56/58 HRC

**EASYPACK** | sacchetto PVC con Euro-hole • PVC bags with Euro-hole

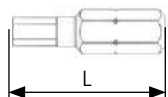

L mm	PCS.	COD.	€ cad./each	
3	30	5	61008005	2,920
4	30	5	61008010	2,920
5	30	5	61008015	2,920
6	30	5	61008020	2,920
8	30	5	61008025	2,920
10	30	5	61008030	2,920





# 2 INSERTI E CHIAVI SPECIALI

BITS AND SPECIAL SETTERS  
EMBOUS ET CLÉS SPÉCIALES  
PUNTAS Y VASOS ESPECIALES

**61099** TX - 5/16" C

INSERTI 5/16" C (C8) PER VITI TORX® PER MECCANICA E CARPENTERIA  
5/16" C (C8) BITS FOR TORX® SCREWS FOR MECHANICAL AND STRUCTURAL WORKS  
EMBOUS 5/16" C (C8) POUR VIS TORX® POUR MÉCANIQUE ET CHARPENTERIE  
PUNTAS DE 5/16" C (C8) PARA TORNILLOS TORX® PARA MECÁNICA Y CONSTRUCCIÓN

56/58 HRC

**EASYPACK** | sacchetto PVC con Euro-hole • PVC bags with Euro-hole

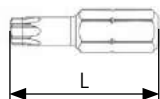

	L mm	PCS.	COD.	€ cad./each
<b>TX20</b>	35	5	61099005	2,790
<b>TX25</b>	35	5	61099010	2,790
<b>TX27</b>	35	5	61099015	2,790
<b>TX30</b>	35	5	61099020	2,790
<b>TX40</b>	35	5	61099025	2,790
<b>TX45</b>	35	5	61099030	2,790
<b>TX50</b>	35	5	61099035	2,790
<b>TX55</b>	35	5	61099040	2,790

**65006** GIRAVITE A PERCUSSIONE

SET 8 PCS GIRAVITE A PERCUSSIONE CON INSERTI 5/16" C ED ESTRATTORI  
8 PCS IMPACT SCREWDRIVER WITH 5/16" C BITS AND EXTRACTORS  
8 PCS TOURNEVIS A CHOC AVEC EMBOUS 5/16" C ET EXTRACTEURS  
8 PCS DESTORNILLADOR DE IMPACTO CON PUNTAS DE 5/16" C Y EXTRACTORES

35 Nm

**NEW!**



8  
pcs.

COD. **65006200**

€ 49,800

PH2	PH3	8	10
1pc.	1pc.	1pc.	1pc.



INCLUSO / INCLUDED  
INCLUDE / INCLUIDO

COD. 62064010

M8-M11 / M11-M14





## 62063 PORTAINSERTI 3/8" CON SFERA

PORTAINSERTI 3/8" CON SFERA PER INSERTI 5/16"C  
3/8" BIT-HOLDER WITH BALL FOR 5/16"C BITS  
PORTE-EMBOUTS 3/8" AVEC BILLE POUR EMBOUTS 5/16"C  
PORTA PUNTAS 3/8" CON ESFERA PARA PUNTAS 5/16"C

**EASYPACK** | sacchetto PVC con Euro-hole • PVC bags with Euro-hole

L mm	Ø mm	PCS.	COD.	€ cad./each
28	17	1	62063010	3,890

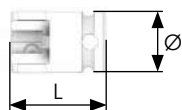

## 62063 PORTAINSERTI 3/8" CON ANELLO C

PORTAINSERTI CON ANELLO C 3/8" PER INSERTI 5/16"C  
3/8" BIT-HOLDER WITH C RING FOR 5/16"C BITS  
PORTE-EMBOUTS 3/8" AVEC BAGUE C POUR EMBOUTS 5/16"C  
PORTA PUNTAS 3/8" CON ANILLO C PARA PUNTAS 5/16"C

**EASYPACK** | sacchetto PVC con Euro-hole • PVC bags with Euro-hole

L mm	Ø mm	PCS.	COD.	€ cad./each
35	19	1	62063005	10,800

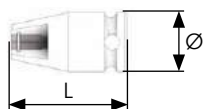



## 2 INSERTI E CHIAVI SPECIALI

BITS AND SPECIAL SETTERS  
EMBOUTS ET CLÉS SPÉCIALES  
PUNTAS Y VASOS ESPECIALES

**62064**

### PORTAINSERTI 1/2" CON SFERA

PORTAINSERTI 1/2" CON SFERA PER INSERTI 5/16"C  
1/2" BIT-HOLDER WITH BALL FOR 5/16"C BITS  
PORTE-EMBOUTS 1/2" AVEC BILLE POUR EMBOUTS 5/16"C  
PORTA PUNTAS 1/2" CON ESFERA PARA PUNTAS 5/16"C

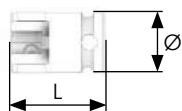

**EASYPACK** | sacchetto PVC con Euro-hole • PVC bags with Euro-hole

L mm	Ø mm	PCS.	COD.	€ cad./each
38	22	1	62064010	5,090

**62064**

### PORTAINSERTI 1/2" CON ANELLO C

PORTAINSERTI 1/2" CON ANELLO C PER INSERTI 5/16"C  
1/2" BIT-HOLDER WITH C RING FOR 5/16"C BITS  
PORTE-EMBOUTS C 1/2" AVEC BAGUE POUR EMBOUTS 5/16"C  
PORTA PUNTAS C 1/2" CON ANILLO PARA PUNTAS 5/16"C

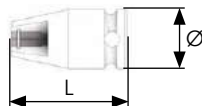

**EASYPACK** | sacchetto PVC con Euro-hole • PVC bags with Euro-hole

L mm	Ø mm	PCS.	COD.	€ cad./each
35	24	1	62064005	12,600





## 61140 PH - 4mm (5/32"-C4)

INSERTI 4mm (5/32" C) PER MICRO-VITI PHILLIPS®  
4mm (5/32" C) BITS FOR PHILLIPS® MICRO-SCREWS  
EMBOUTS 4mm (5/32" C) POUR MICRO-VIS PHILLIPS®  
PUNTAS DE 4mm (5/32" C) PARA MICRO-TORNILLOS PHILLIPS®

58/60 HRC

**EASYPACK** | sacchetto PVC con Euro-hole • PVC bags with Euro-hole

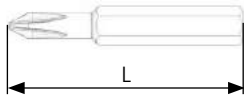

	L mm	PCS.	COD.	€ cad./each
<b>PH00</b>	28	10	61140001	1,000
<b>PH00</b>	28	10	61140002	1,000
<b>PH0</b>	28	10	61140005	1,000
<b>PH1</b>	28	10	61140010	1,000
<b>PH2</b>	28	10	61140020	1,000

## 61142 TX - 4mm (5/32"-C4)

INSERTI 4mm (5/32" C) PER MICRO-VITI TORX®  
4mm (5/32" C) BITS FOR TORX® MICRO-SCREWS  
EMBOUTS 4mm (5/32" C) POUR MICRO-VIS TORX®  
PUNTAS DE 4mm (5/32" C) PARA MICRO-TORNILLOS TORX®

58/60 HRC

**EASYPACK** | sacchetto PVC con Euro-hole • PVC bags with Euro-hole

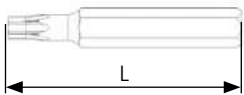

	L mm	PCS.	COD.	€ cad./each
<b>TX03</b>	28	10	61142005	1,050
<b>TX04</b>	28	10	61142010	1,050
<b>TX05</b>	28	10	61142015	1,050
<b>TX06</b>	28	10	61142020	1,050
<b>TX07</b>	28	10	61142025	1,050
<b>TX08</b>	28	10	61142030	1,050

2



## 61143 ESAGONO 4mm (5/32"-C4)

INSERTI 4mm (5/32" C) PER MICRO-VITI ESAGONALI  
4mm (5/32" C) BITS FOR HEXAGON MICRO-SCREWS  
EMBOUTS 4mm (5/32" C) POUR MICRO-VIS 6 PANS  
PUNTAS DE 4mm (5/32" C) PARA MICRO-TORNILLOS HEXAGONALES

58/60 HRC

**EASYPACK** | sacchetto PVC con Euro-hole • PVC bags with Euro-hole

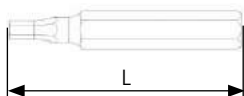

	L mm	PCS.	COD.	€ cad./each
<b>0,7</b>	28	10	61143005	1,130
<b>0,9</b>	28	10	61143010	1,130
<b>1,3</b>	28	10	61143015	1,130



# 2 INSERTI E CHIAVI SPECIALI

BITS AND SPECIAL SETTERS  
EMBOUS ET CLÉS SPÉCIALES  
PUNTAS Y VASOS ESPECIALES

## 61144 TAGLIO 4mm (5/32"-C4)

INSERTI 4mm (5/32" C) PER MICRO-VITI A TAGLIO  
4mm (5/32" C) BITS FOR SLOTTED MICRO-SCREWS  
EMBOUS 4mm (5/32" C) POUR MICRO-VIS À FENTE  
PUNTAS DE 4mm (5/32" C) PARA MICRO-TORNILLOS DE CORTE

58/60 HRC

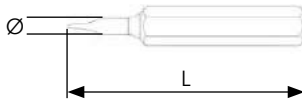

**EASYPACK** | sacchetto PVC con Euro-hole • PVC bags with Euro-hole

Ø mm	L mm	PCS.	COD.	€ cad./each
0,3	1,5	28	61144005	1,080
0,37	1,8	28	61144010	1,080
0,4	2	28	61144015	1,080
0,4	2,5	28	61144020	1,080

## 61146 PENTALOBE 4mm (5/32"-C4)

INSERTI 4mm (5/32" C) PER MICRO-VITI PENTALOBATE  
4mm (5/32" C) BITS FOR 5-LOBED MICRO-SCREWS  
EMBOUS 4mm (5/32" C) POUR MICRO-VIS PENTALOBÉE  
PUNTAS DE 4mm (5/32" C) PARA MICRO-TORNILLOS DE CINCO LÓBULOS

58/60 HRC

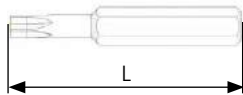

**EASYPACK** | sacchetto PVC con Euro-hole • PVC bags with Euro-hole

L mm	PCS.	COD.	€ cad./each
P1 28	10	61046005	1,500
P4 28	10	61046020	1,500



### FOCUS ON



I dispositivi elettronici sono ormai nelle mani di tutti e, con loro, le micro viti sono largamente diffuse. Prerogativa di questo tipo di fasteners è l'estrema precisione.

Suitable for the production of electronic devices where micro-screws are widely used. The special feature of this type of fastener is its extreme precision.

Dans le domaine des appareils électroniques où les micro-vis sont largement diffusées, la précision extrême est la prérogative de ce type de fixation.

En el campo de los dispositivos electrónicos donde los micro tornillos son muy difundidos. Prerogativa de este tipo de sujeción es la extrema precisión.



# 66015 ASSORTIMENTI INSERTI DI PRECISIONE

ASSORTIMENTO 22 PCS. INSERTI PER MICRO-VITI CON IMPUGNATURA E PROLUNGA  
 SET OF 22 BITS FOR MICRO-SCREWS WITH HANDLE AND EXTENSION  
 JEU DE 22 PIÈCES EMBOUTS POUR MICRO-VIS AVEC POIGNÉE ET RALLONGE  
 JUEGO DE 22 PIEZAS PARA MICRO-TORNILLOS CON MANGO Y EXTENSIÓN

22 pcs.

COD. **66015001**  
 € 34,800

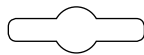

EURO-HOLE

135 X 35 X 70 mm

INCLUSO / INCLUDED / INCLUSE / INCLUIDO

COD. 62001015



COD. 62001100



61140



PH000 1pc.	PH00 1pc.	PH0 1pc.	PH1 1pc.	PH2 1pc.
---------------	--------------	-------------	-------------	-------------

61142



TX03 1pc.	TX04 1pc.	TX05 1pc.	TX06 1pc.	TX07 1pc.	TX08 1pc.
--------------	--------------	--------------	--------------	--------------	--------------

61144



0,3x1,5 1pc.	0,37x 1,8 1pc.	0,4x2,0 1pc.	0,4x2,5 1pc.
-----------------	-------------------	-----------------	-----------------

61143



0,7 1pc.	0,9 1pc.	1,3 1pc.
-------------	-------------	-------------

61146



P1 1pc.	P4 1pc.
------------	------------

2



## FOCUS ON

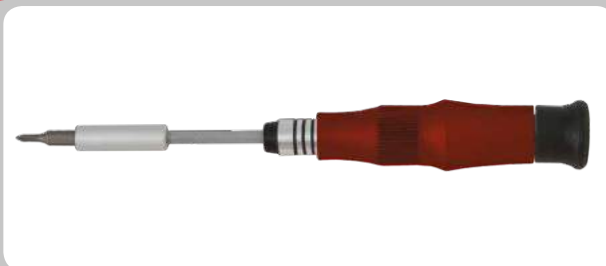

Per completare l'assortimento delle impronte per micro-viti più usate, abbiamo aggiunto un'impugnatura in alluminio con mandrino rapido di elevata qualità praticità ed una prolunga magnetica.

To complete the range of tips for the most common micro-screws, we have added a practical aluminium handle with a chuck of the highest quality and magnetic extension.

Pour compléter l'assortiment des empreintes pour micro-vis les plus utilisées, nous avons ajouté une poignée en aluminium avec mandrin rapide de haute qualité très pratique et une rallonge aimantée.

Para completar el surtido de huellas para micro tornillos más usadas, hemos añadido un mango de aluminio con mandril rápido de elevada calidad y practicidad y una extensión magnética.

# LAB TEST





# 2 INSERTI E CHIAVI SPECIALI

BITS AND SPECIAL SETTERS  
EMBOUS ET CLÉS SPÉCIALES  
PUNTAS Y VASOS ESPECIALES

**66015**

ASSORTIMENTI INSERTI DI PRECISIONE

ASSORTIMENTO 17 PCS INSERTI PER MICRO VITI CON ACCESSORI  
17 PCS SET BITS FOR MICRO-SCREWS AND ACCESSORIES  
JEU DE 17 PCS EMBOUTS POUR MICRO-VIS ET ACCESSOIRES  
JUEGO 17 PCS PUNTAS PARA MICRO-TORNILLOS CON ACCESORIOS

**NEW!**

17  
pcs.



COD. **66015010**

€ 14,900

PH000 1pc.	PH00 1pc.	PH0 1pc.	TX02 1pc.	TX03 1pc.	TX05 1pc.	TX06 1pc.
1,0x0,3 1pc.	2,0x0,4 1pc.	2,6 1pc.	P2 1pc.	P5 1pc.		



220 X 30 X 130 mm

INCLUSO / INCLUDED / INCLUDE / INCLUIDO





# 66015 ASSORTIMENTI INSERTI DI PRECISIONE

ASSORTIMENTO 50 PCS INSERTI PER MICRO VITI CON ACCESSORI  
 50 PCS SET BITS FOR MICRO-SCREWS AND ACCESSORIES  
 JEU DE 50 PCS EMBOUTS POUR MICRO-VIS ET ACCESSOIRES  
 JUEGO 50 PCS PUNTAS PARA MICRO-TORNILLOS CON ACCESORIOS

**NEW!**

50 pcs.



COD. **66015011**

€ 39,600

PH000 1pc.			PH00 1pc.			PH0 1pc.			PH1 1pc.			TX03 1pc.			TX04 1pc.			TX05 1pc.		
TXH06 1pc.			TXH07 1pc.			TXH08 1pc.			TXH09 1pc.			TXH10 1pc.			TXH15 1pc.					
1,0x0,3 1pc.			1,5x0,3 1pc.			2,0x0,4 1pc.			2,5x0,4 1pc.			3,x4 1pc.								
0 1pc.			1 1pc.			P2 1pc.			P5 1pc.			P6 1pc.								
0,9 1pc.			1,3 1pc.			1,5 1pc.			2 1pc.			2,5 1pc.			3 1pc.					
0,8 1pc.			0 1pc.			1 1pc.			1,6 1pc.			2 1pc.			2,2 1pc.			2,3 1pc.		
2,5 1pc.			3 1pc.			3,5 1pc.			4 1pc.			4,5 1pc.			5 1pc.					

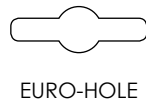

EURO-HOLE

240 X 45 X 110 mm





# 2 INSERTI E CHIAVI SPECIALI

BITS AND SPECIAL SETTERS  
EMBOUS ET CLÉS SPÉCIALES  
PUNTAS Y VASOS ESPECIALES

## 62001 PORTAINSERTI 3mm MAGNETICI

PORTAINSERTI MAGNETICO 3mm PER INSERTI 4mm (5/32" C)  
3mm MAGNETIC BIT-HOLDER FOR 4mm (5/32" C) BITS  
PORTE-EMBOUS MAGNÉTIQUE 3 mm POUR EMBOUS 4 mm (5/32" C)  
PORTA PUNTAS MAGNÉTICO DE 3mm PARA PUNTAS 4mm (5/32" C)

**EASYPACK** | sacchetto PVC con Euro-hole • PVC bags with Euro-hole



L mm	Ø mm	PCS.	COD.	€ cad./each
55	6,5	5	62001005	37,500

## 62001 PORTAINSERTI 1/4" E MAGNETICI

PORTAINSERTI MAGNETICO 1/4" E PER INSERTI 4mm (5/32" C)  
1/4" E MAGNETIC BIT-HOLDER FOR BITS 4mm (5/32" C)  
PORTE-EMBOUS MAGNÉTIQUE 1/4" E POUR EMBOUS 4mm (5/32" C)  
PORTA PUNTAS MAGNÉTICO DE 1/4" E PARA PUNTAS 4mm (5/32" C)

**EASYPACK** | sacchetto PVC con Euro-hole • PVC bags with Euro-hole

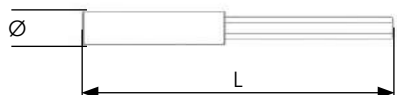

L mm	Ø mm	PCS.	COD.	€ cad./each
75	8,5	1	62001010	11,800



## 62001 PROLUNGHE 4mm (5/32" C)

PROLUNGA 4mm (5/32" C) PER INSERTI 4mm (5/32" C) CON ANELLO C  
4mm (5/32" C) EXTENSION FOR 4mm (5/32" C) BITS WITH C RING  
RALLONGE 4mm (5/32" C) POUR EMBOUTS 4mm (5/32" C) AVEC BAGUE C  
EXTENSIÓN 4mm (5/32" C) PARA PUNTAS 4mm (5/32" C) CON ANILLO C

**EASYPACK** | sacchetto PVC con Euro-hole • PVC bags with Euro-hole

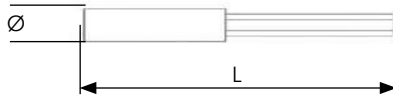

L mm	Ø mm	PCS.	COD.	€ cad./each
70	7,5	1	62001015	5,90

## 62001 IMPUGNATURE DI PRECISIONE IN ALLUMINIO

IMPUGNATURA CON BLOCCO PER INSERTI 4mm (5/32" C)  
HANDLE WITH LOCK FOR 4mm (5/32" C) BITS  
POIGNÉE AVEC BLOQUAGE POUR EMBOUTS 4mm (5/32" C)  
MANGO CON BLOQUEO PARA PUNTAS 4mm (5/32" C)

**EASYPACK** | sacchetto PVC con Euro-hole • PVC bags with Euro-hole

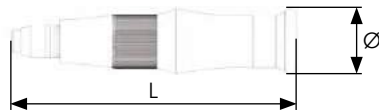

L mm	Ø mm	PCS.	COD.	€ cad./each
90	20	1	62001100	21,70





# 2 INSERTI E CHIAVI SPECIALI

BITS AND SPECIAL SETTERS  
EMBOUS ET CLÉS SPÉCIALES  
PUNTAS Y VASOS ESPECIALES

**61035** PH - M4

INSERTI M4 PHILLIPS® PER AVVITATORI AUTOALIMENTATI  
PHILLIPS® M4 BITS FOR SELF-POWERED DRIVERS  
EMBOUS M4 PHILLIPS® POUR VISSEUSES AUTOALIMENTÉES  
PUNTAS M4 PHILLIPS® PARA ATORNILLADORES AUTOALIMENTADOS

59/61 HRC

**EASYPACK** | sacchetto PVC con Euro-hole • PVC bags with Euro-hole

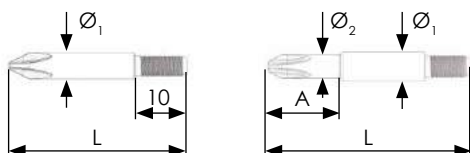

	L mm	Ø <sub>1</sub> mm	Ø <sub>2</sub> mmxA	PCS.	COD.	€ cad./each
	33	5		10	61035005	5,360
PH1	34	5		10	61035010	5,360
	45	6	5x15	10	61035015	5,630
PH2	34	6		10	61035020	5,360
	45	6		10	61035025	5,630

**61061** PZ - M4

INSERTI M4 POZIDRIV® PER AVVITATORI AUTOALIMENTATI  
POZIDRIV® M4 BITS FOR SELF-POWERED DRIVERS  
EMBOUS M4 POZIDRIV® POUR VISSEUSES AUTOALIMENTÉES  
PUNTAS M4 POZIDRIV® PARA ATORNILLADORES AUTOALIMENTADOS

59/61 HRC

**EASYPACK** | sacchetto PVC con Euro-hole • PVC bags with Euro-hole

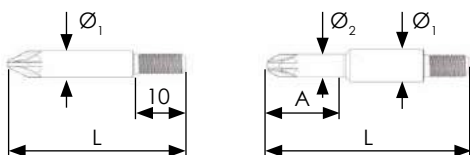

	L mm	Ø <sub>1</sub> mm	Ø <sub>2</sub> mmxA	PCS.	COD.	€ cad./each
	33	5		10	61061005	5,360
PZ1	34	5		10	61061010	5,360
	45	6	5x15	10	61061015	5,630
PZ2	34	6		10	61061020	5,360
	45	6		10	61061025	5,630

**61091** TX - M4

INSERTI M4 PER VITI TORX® PER AVVITATORI AUTOALIMENTATI  
M4 BITS FOR TORX® SCREWS FOR SELF-POWERED DRIVERS  
EMBOUS M4 POUR VIS TORX® POUR VISSEUSES AUTOALIMENTÉES  
PUNTAS M4 PARA TORNILLOS TORX® PARA ATORNILLADORES AUTOALIMENTADOS

59/61 HRC

**EASYPACK** | sacchetto PVC con Euro-hole • PVC bags with Euro-hole

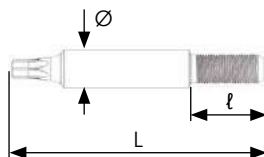

	L mm	l mm	Ø mm	PCS.	COD.	€ cad./each
TX08	33	10	5	10	61091004	6,700
TX09	33	10	5	10	61091005	6,700
TX10	33	10	5	10	61091010	6,700
TX15	33	10	6	10	61091015	6,700
TX20	33	10	6	10	61091020	6,700
TX25	33	10	6	10	61091025	6,700





## 62005 PORTAINSERTI 1/4"E PER INSERTI M4

PORTAINSERTI 1/4"E PER INSERTI M4  
1/4"E BIT-HOLDER FOR M4 BITS  
PORTE-EMBOUTS 1/4"E POUR EMBOUTS M4  
PORTA PUNTAS DE 1/4"E PARA PUNTAS M4

**EASYPACK** | sacchetto PVC con Euro-hole • PVC bags with Euro-hole

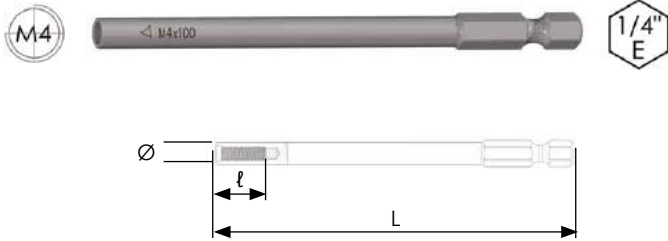

L mm	l mm	Ø mm	PCS.	COD.	€ cad./each
75	15	6	5	62005005	24,200
100	15	6	5	62005010	27,500
175	15	6	5	62005015	32,200



### FOCUS ON

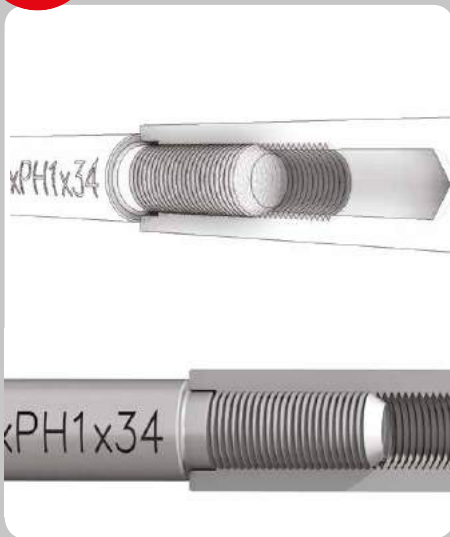

Connessione di tipo rinforzato, ottimizza la resistenza del filetto evitando la necessità di ridurre la durezza. Il sistema inserto + portainseriti risulta estremamente indicato nell'applicazioni industriali con avvitatori automatici/autoalimentati e su impianti di avvitatura complessi. In questi casi sono estremamente importanti l'affidabilità del prodotto e la sua capacità di resistere all'usura. Per questi motivi i nostri inserti vengono realizzati con tolleranze minime su macchine estremamente precise con l'obiettivo di garantire la massima qualità. La connessione di tipo rinforzato permette inoltre di mantenere elevata la durezza dell'inserto.

Reinforced connection optimises the resistance of the thread, preventing the need to reduce the hardness. The bit + bit-holder system is very suitable in industrial applications that use automatic/self-powered drivers and complex screwing systems. In these cases, product reliability and wear resistance are extremely important. For these reasons, our bits are manufactured with minimum tolerances on high-precision machines aimed at ensuring maximum quality. The reinforced connection also allows maintaining excellent hardness of the bit.

Raccord renforcé, il optimise la résistance du filetage en évitant la nécessité d'en réduire la dureté. Le système embout + porte-embout est particulièrement indiqué dans les applications industrielles avec visseuses automatiques/autoalimentées et sur des installations de vissage complexes. Dans ces cas, la fiabilité du produit et sa capacité à résister à l'usure sont extrêmement importantes. Pour ces raisons, nos embouts sont fabriqués avec des tolérances minimum sur des machines extrêmement précises afin d'assurer la meilleure qualité. Le raccord de type renforcé permet de maintenir une dureté élevée de l'embout.

Conexión de tipo reforzado, optimiza la resistencia de la rosca evitando la necesidad de tener que reducir la dureza.

El sistema punta + porta puntas resulta especialmente indicado en las aplicaciones industriales con atomilladores automáticos/auto alimentados y en los sistemas de atomillado complejos. En estos casos es muy importante la fiabilidad del producto y su capacidad de resistir al desgaste. Por estas razones nuestras puntas se realizan con mínimas tolerancias sobre máquinas muy precisas con el objeto de garantizar la máxima calidad. Además las conexiones de tipo reforzado permiten mantener elevada la dureza de la punta.



# 2 INSERTI E CHIAVI SPECIALI

BITS AND SPECIAL SETTERS  
EMBOUS ET CLÉS SPÉCIALES  
PUNTAS Y VASOS ESPECIALES

**61036** PH - M5

INSERTI M5 PHILLIPS® PER AVVITATORI AUTOALIMENTATI  
PHILLIPS® M5 BITS FOR SELF-POWERED DRIVERS  
EMBOUS M5 PHILLIPS® POUR VISSEUSES AUTOALIMENTÉES  
PUNTAS M5 PHILLIPS® PARA ATORNILLADORES AUTOALIMENTADOS

59/61 HRC

**EASYPACK** | sacchetto PVC con Euro-hole • PVC bags with Euro-hole

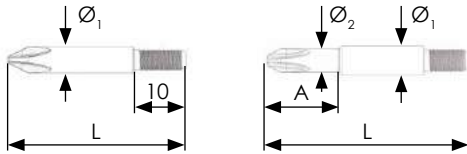

	L mm	Ø <sub>1</sub> mm	Ø <sub>2</sub> mmxA	PCS.	COD.	€ cad./each
PH1	34	6,5		10	61036005	4,770
	45	6	5x15	10	61036010	5,090
	31	7		10	61036013	4,770
PH2	33	6		10	61036014	4,770
	33	7		10	61036015	4,770
	34	6,5		10	61036020	4,770
	45	6		10	61036023	5,090
	45	6,5		10	61036025	5,090

**61062** PZ - M5

INSERTI M5 POZIDRIV® PER AVVITATORI AUTOALIMENTATI  
POZIDRIV® M5 BITS FOR SELF-POWERED DRIVERS  
EMBOUS M5 POZIDRIV® POUR VISSEUSES AUTOALIMENTÉES  
PUNTAS M5 POZIDRIV® PARA ATORNILLADORES AUTOALIMENTADOS

59/61 HRC

**EASYPACK** | sacchetto PVC con Euro-hole • PVC bags with Euro-hole

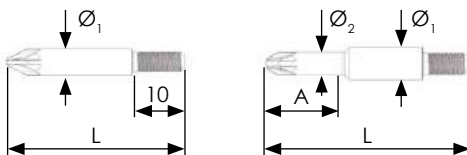

	L mm	Ø <sub>1</sub> mm	Ø <sub>2</sub> mmxA	PCS.	COD.	€ cad./each
PZ1	34	6,5		10	61062005	4,770
	45	6	5x15	10	61062010	5,090
	31	7		10	61062013	4,770
PZ2	33	6		10	61062014	4,770
	33	7		10	61062015	4,770
	34	6,5		10	61062020	4,770
	45	6		10	61062023	5,090
	45	6,5		10	61062025	5,090

**61110** TXH - M5

INSERTI M5 PER VITI TORX® ANTI-MANOMISSIONE PER AVVITATORI AUTOALIMENTATI  
M5 BITS FOR TORX® TAMPER-RESISTANT SCREWS FOR SELF-POWERED DRIVERS  
EMBOUS M5 POUR VIS TORX® DE SÉCURITÉ POUR VISSEUSES AUTOALIMENTÉES  
PUNTAS M5 PARA TORNILLOS TORX® ANTIMANIPULACIÓN PARA ATORNILLADORES AUTOALIMENTADOS

59/61 HRC

**EASYPACK** | sacchetto PVC con Euro-hole • PVC bags with Euro-hole

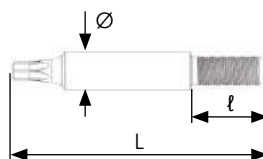

	L mm	l mm	Ø mm	PCS.	COD.	€ cad./each
TXH15	33	10	7	10	61110005	8,310
TXH20	33	10	7	10	61110010	8,310
TXH25	33	10	7	10	61110015	8,310



## 61092 TX - M5

59/61 HRC

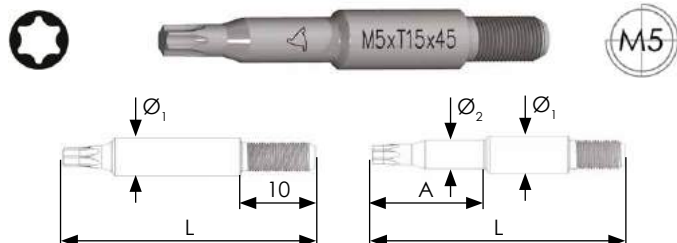

INSERTI M5 PER VITI TORX® PER AVVITATORI AUTOALIMENTATI  
M5 BITS FOR TORX® SCREWS FOR SELF-POWERED DRIVERS  
EMBOUTS M5 POUR VIS TORX® POUR VISSEUSES AUTOALIMENTÉES  
PUNTAS M5 PARA TORNILLOS TORX® PARA ATORNILLADORES AUTOALIMENTADOS

**EASYPACK** | sacchetto PVC con Euro-hole • PVC bags with Euro-hole

	L mm	Ø <sub>1</sub> mm	Ø <sub>2</sub> mmxA	PCS.	COD.	€ cad./each
	33	6,5		10	61092002	6,430
<b>TX10</b>	45	6		10	61092004	6,830
	45	6,5	5x20	10	61092005	6,830
	33	6,5		10	61092010	6,430
<b>TX15</b>	45	6		10	61092014	6,830
	45	6,5	5x20	10	61092015	6,830
	33	6,5		10	61092020	6,430
<b>TX20</b>	45	6		10	61092024	6,830
	45	6,5		10	61092025	6,830
	33	6,5		10	61092030	6,430
<b>TX25</b>	45	6		10	61092034	6,830
	45	7		10	61092035	6,830
	33	7		10	61092037	6,430
<b>TX30</b>	45	7		10	61092040	6,830
<b>TX40</b>	45	7		10	61092045	6,830

## 62006 PORTAINSERTI 1/4"E PER INSERTI M5

PORTAINSERTI 1/4"E PER INSERTI M5  
1/4"E BIT-HOLDER FOR M5 BITS  
PORTE-EMBOUTS 1/4"E POUR EMBOUTS M5  
PORTA PUNTAS DE 1/4"E PARA PUNTAS M5

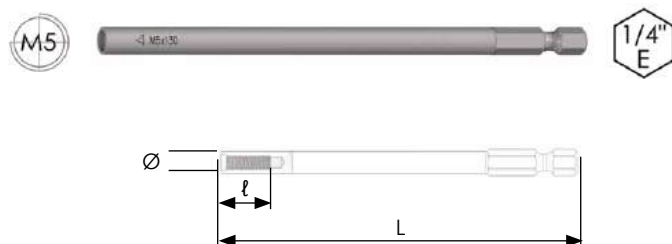

**EASYPACK** | sacchetto PVC con Euro-hole • PVC bags with Euro-hole

L mm	l mm	Ø mm	PCS.	COD.	€ cad./each
<b>85</b>	15	7	5	62006035	24,700
<b>125</b>	15	7	5	62006010	25,000
<b>130</b>	15	7	5	62006005	25,200
<b>135</b>	15	7	5	62006040	26,000
<b>150</b>	15	7	5	62006015	26,800
<b>165</b>	15	7	5	62006045	27,500
<b>175</b>	15	7	5	62006020	28,200
<b>200</b>	15	7	5	62006025	32,200



# 2 INSERTI E CHIAVI SPECIALI

BITS AND SPECIAL SETTERS  
EMBOUS ET CLÉS SPÉCIALES  
PUNTAS Y VASOS ESPECIALES

## 61037 PH - M6

INSERTI M6 PHILLIPS® PER AVVITATORI AUTOALIMENTATI  
PHILLIPS® M6 BITS FOR SELF-POWERED DRIVERS  
EMBOUS M6 PHILLIPS® POUR VISSEUSES AUTOALIMENTÉES  
PUNTAS M6 PHILLIPS® PARA ATORNILLADORES AUTOALIMENTADOS

59/61 HRC

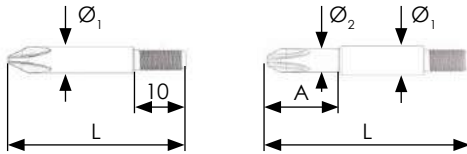

**EASYPACK** | sacchetto PVC con Euro-hole • PVC bags with Euro-hole

	L mm	Ø <sub>1</sub> mm	Ø <sub>2</sub> mmxA	PCS.	COD.	€ cad./each
	33	8		10	61037002	6,570
<b>PH2</b>	45	8		10	61037010	6,830
	44	7	5x10	10	61037005	6,830
<b>PH3</b>	34	8	7,5x18	10	61037015	6,570
	45	8		10	61037020	6,830

## 61063 PZ - M6

INSERTI M6 POZIDRIV® PER AVVITATORI AUTOALIMENTATI  
POZIDRIV® M6 BITS FOR SELF-POWERED DRIVERS  
EMBOUS M6 POZIDRIV® POUR VISSEUSES AUTOALIMENTÉES  
PUNTAS M6 POZIDRIV® PARA ATORNILLADORES AUTOALIMENTADOS

59/61 HRC

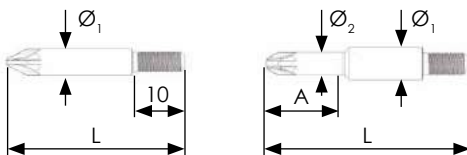

**EASYPACK** | sacchetto PVC con Euro-hole • PVC bags with Euro-hole

	L mm	Ø <sub>1</sub> mm	Ø <sub>2</sub> mmxA	PCS.	COD.	€ cad./each
	33	8		10	61063002	6,570
<b>PZ2</b>	45	8		10	61063005	6,830
	34	8,5	7,5x18	10	61063010	6,570
<b>PZ3</b>	45	8		10	61063015	6,830

## 61093 TX - M6

INSERTI M6 PER VITI TORX® PER AVVITATORI AUTOALIMENTATI  
M6 BITS FOR TORX® SCREWS FOR SELF-POWERED DRIVERS  
EMBOUS M6 POUR VIS TORX® POUR VISSEUSES AUTOALIMENTÉES  
PUNTAS M6 PARA TORNILLOS TORX® PARA ATORNILLADORES AUTOALIMENTADOS

59/61 HRC

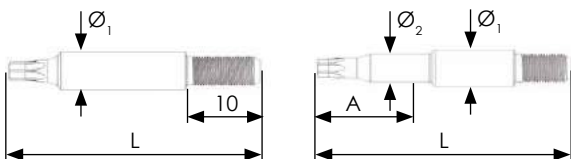

**EASYPACK** | sacchetto PVC con Euro-hole • PVC bags with Euro-hole

	L mm	Ø <sub>1</sub> mm	Ø <sub>2</sub> mmxA	PCS.	COD.	€ cad./each
<b>TX15</b>	45	8		10	61093002	7,230
<b>TX20</b>	33	8	4x16	10	61093003	6,970
	45	8	5x25	10	61093005	7,230
<b>TX25</b>	33	8		10	61093010	6,970
	45	8		10	61093012	7,230
<b>TX30</b>	33	8		10	61093014	6,970
	45	8		10	61093015	7,230
<b>TX40</b>	45	8		10	61093020	7,230



## 62007 PORTAINSERTI 1/4"E PER INSERTI M6

PORTAINSERTI 1/4"E PER INSERTI M6  
1/4"E BIT-HOLDER FOR M6 BITS  
PORTE-EMBOUTS 1/4"E POUR EMBOUTS M6  
PORTA PUNTAS DE 1/4"E PARA PUNTAS M6

**EASYPACK** | sacchetto PVC con Euro-hole • PVC bags with Euro-hole

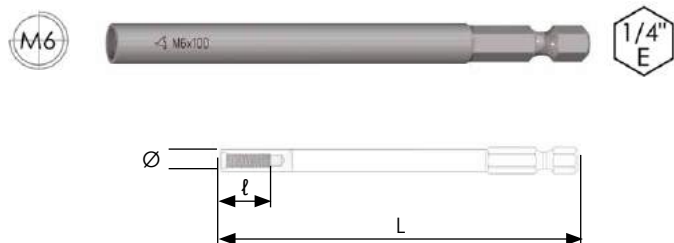

L mm	ℓ mm	Ø mm	PCS.	COD.	€ cad./each
100	15	10	5	62007005	27,600
165	15	8	5	62007010	32,200
200	15	8	5	62007015	32,200



### FOCUS ON

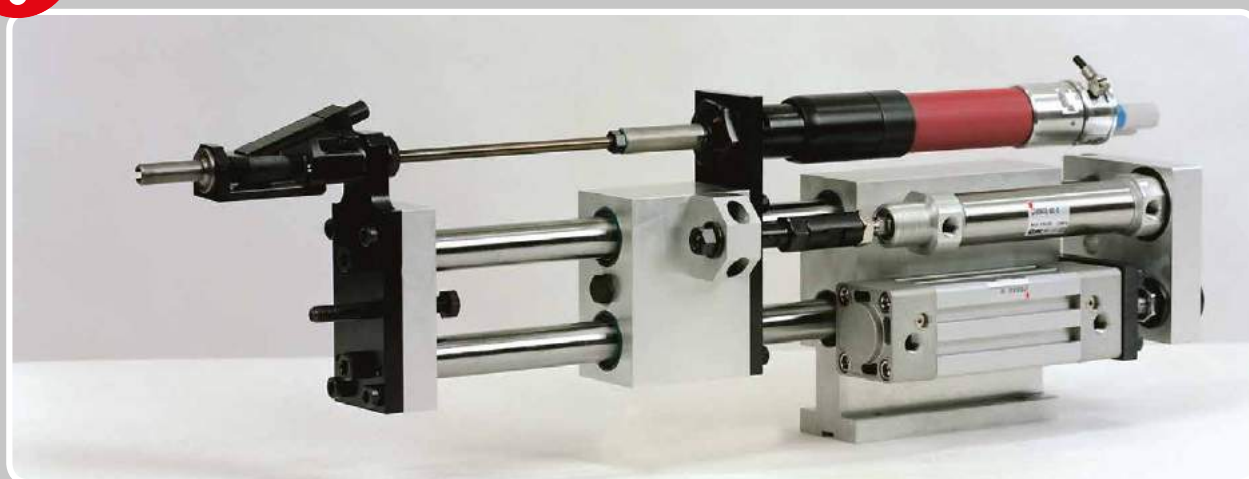

*Esempio di avvitatore autoalimentato con applicazione di portainseriti ed inserto filettati (per gentile concessione di MTA TECH S.r.l.)  
Example of self-powered screwdriver with application of bit holder and threaded insert (by kind permission of MTA TECH S.r.l.)  
Exemple de visseuse autoalimentée avec application de porte-embouts et embout filetés (avec l'aimable autorisation de MTA TECH S.r.l.)  
Ejemplo de atornillador autoalimentado con aplicación de porta puntas e inserto roscados (gracias a la concesión de MTA TECH S.r.l.)*

I nostri portainseriti filettati sono realizzati con lo stesso acciaio di alta qualità che utilizziamo per gli inserti. Il trattamento termico è calibrato per ottenere anche in questo caso il miglior equilibrio tra durezza e tenacità. Come ultima fase di lavorazione, prima dello stoccaggio, viene controllata la rettilinearità di questi prodotti e viene eventualmente eseguita un'operazione di raddrizzatura al fine di garantire una concentricità non inferiore a 0,1mm.

Our threaded bit holders are made with the same high-quality steel used for the bits. The heat treatment is calibrated to obtain the best balance between hardness and toughness. As a final machining phase before storage, the straightness of these products is checked and if necessary, they are straightened to ensure concentricity of not less than 0.1 mm.

Nos porte-embouts filetés sont fabriqués avec le même acier de haute qualité que nous utilisons pour les embouts. Le traitement thermique est calibré pour obtenir, dans ce cas également, un meilleur équilibre entre dureté et ténacité. Comme dernière étape d'usinage, avant le stockage, la rectilinéarité de ces produits est contrôlée et une opération de redressage est effectuée afin de garantir une concentricité d'au moins 0,1 mm.

Nuestros porta puntas han sido realizados con el mismo acero de alta calidad que se usa para las puntas. El tratamiento térmico está calibrado para obtener también en este caso el mejor equilibrio entre dureza y tenacidad. Como última fase de elaboración, antes del almacenaje, se controla que los productos estén derechos y eventualmente se realiza una operación de enderezamiento con el fin de garantizar una concentricidad por debajo de los 0,1mm.





# 2 INSERTI E CHIAVI SPECIALI

BITS AND SPECIAL SETTERS  
EMBOUS ET CLÉS SPÉCIALES  
PUNTAS Y VASOS ESPECIALES

## 61039 PH - UNF 10x32

INSERTI UNF 10x32 PHILLIPS® PER AVVITATORI AUTOALIMENTATI  
PHILLIPS® UNF 10x32 BITS FOR SELF-POWERED DRIVERS  
EMBOUS UNF 10x32 PHILLIPS® POUR VISSEUSES AUTOALIMENTÉES  
PUNTAS UNF 10x32 PHILLIPS® PARA ATORNILLADORES AUTOALIMENTADOS

59/61 HRC

**EASYPACK** | sacchetto PVC con Euro-hole • PVC bags with Euro-hole

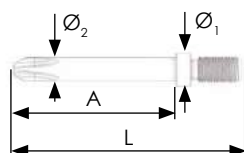

	L mm	Ø <sub>1</sub> mm	Ø <sub>2</sub> mmxA	PCS.	COD.	€ cad./each
<b>PH1</b>	45	6,5	4,5x32	10	61039005	6,970
<b>PH2</b>	45	6,5	4,5x32	10	61039010	6,970

## 61065 PZ - UNF 10x32

INSERTI UNF 10x32 POZIDRIV® PER AVVITATORI AUTOALIMENTATI  
POZIDRIV® UNF 10x32 BITS FOR SELF-POWERED DRIVERS  
EMBOUS UNF 10x32 POZIDRIV® POUR VISSEUSES AUTOALIMENTÉES  
PUNTAS UNF 10x32 POZIDRIV® PARA ATORNILLADORES AUTOALIMENTADOS

59/61 HRC

**EASYPACK** | sacchetto PVC con Euro-hole • PVC bags with Euro-hole

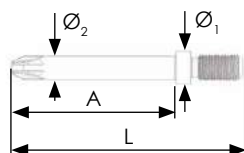

	L mm	Ø <sub>1</sub> mm	Ø <sub>2</sub> mmxA	PCS.	COD.	€ cad./each
<b>PZ1</b>	45	6,5	4,5x32	10	61065005	6,970
<b>PZ2</b>	45	6,5	4,5x32	10	61065010	6,970

## 61090 TX - UNF 10x32

INSERTI UNF 10x32 PER VITI TORX® PER AVVITATORI AUTOALIMENTATI  
UNF 10x32 BITS FOR TORX® SCREWS FOR SELF-POWERED DRIVERS  
EMBOUS UNF 10x32 POUR VIS TORX® POUR VISSEUSES AUTOALIMENTÉES  
PUNTAS UNF 10x32 PARA TORNILLOS TORX® PARA ATORNILLADORES AUTOALIMENTADOS

59/61 HRC

**EASYPACK** | sacchetto PVC con Euro-hole • PVC bags with Euro-hole

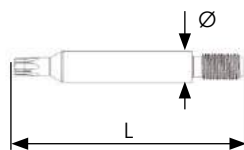

	L mm	Ø mm	PCS.	COD.	€ cad./each
<b>TX10</b>	45	6	10	61090005	7,230
<b>TX15</b>	45	6	10	61090010	7,230
<b>TX20</b>	45	6	10	61090015	7,230
<b>TX25</b>	45	6	10	61090020	7,230
<b>TX30</b>	45	6	10	61090025	7,230



## 62009 PORTAINSERTI 1/4"E PER INSERTI UNF 10x32

PORTAINSERTI 1/4"E PER INSERTI UNF 10x32  
1/4"E BIT-HOLDER FOR UNF 10x32 BITS  
PORTE-EMBOUS 1/4"E POUR EMOUS UNF 10x32  
PORTA PUNTAS DE 1/4"E PARA PUNTAS UNF 10x32

**EASYPACK** | sacchetto PVC con Euro-hole • PVC bags with Euro-hole

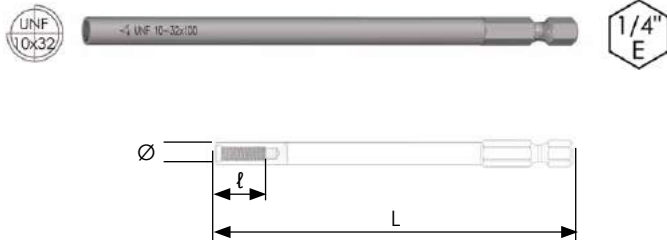

L mm	l mm	Ø mm	PCS.	COD.	€ cad./each
100	15	7	5	62009005	25,000
117	15	7	5	62009010	26,000
175	15	7	5	62009015	35,500



### FOCUS ON



Versione specifica per macchine assemblaggio serramenti (a richiesta).  
Specific version for assembly machines.  
Version spécifique pour machines d'assemblage d'huissieries.  
Versión específica para máquinas de ensamblaje de cerrajería.

2

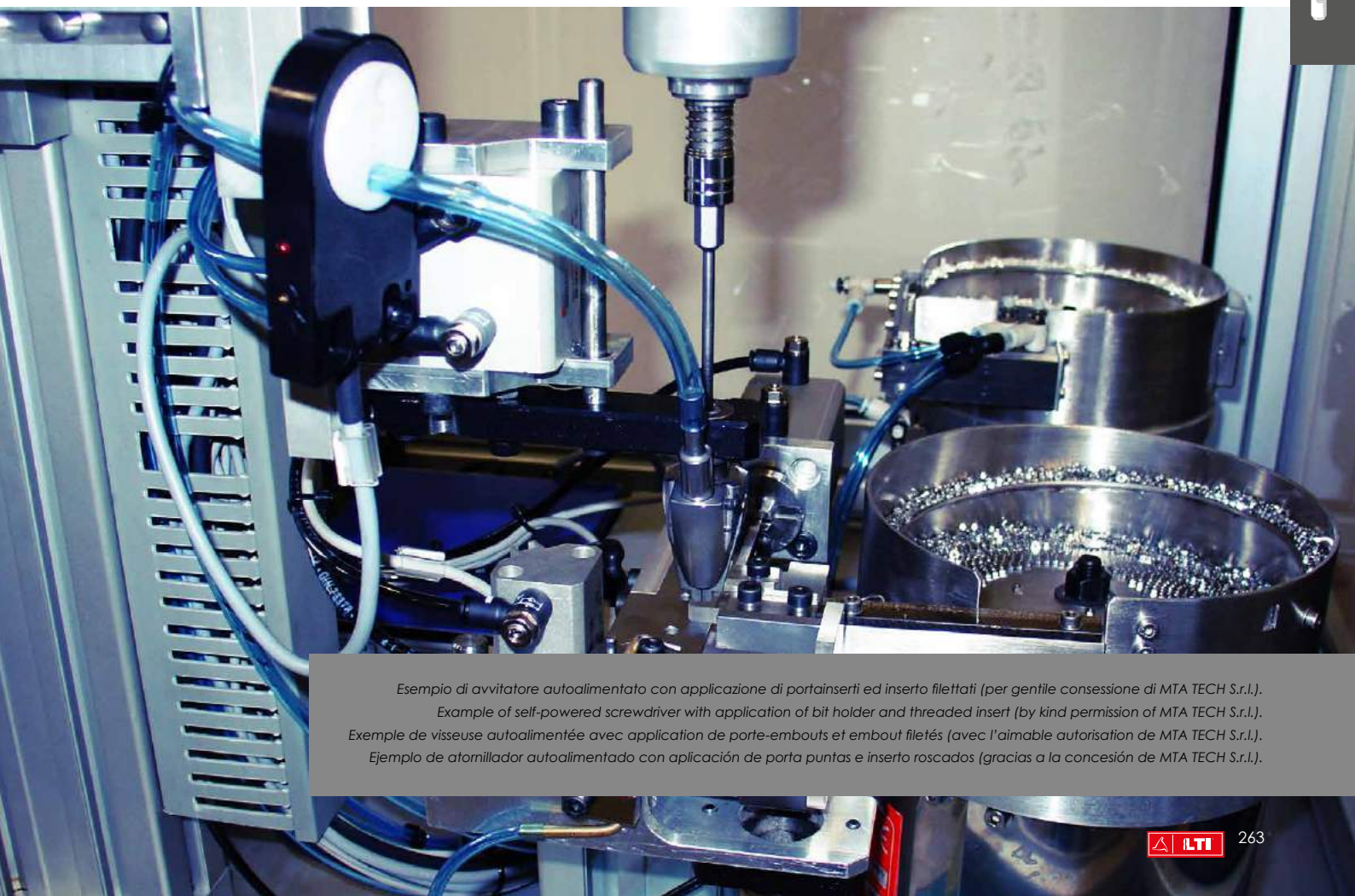

Esempio di avvitatore autoalimentato con applicazione di portainseriti ed inserto filettati (per gentile concessione di MTA TECH S.r.l.).  
Example of self-powered screwdriver with application of bit holder and threaded insert (by kind permission of MTA TECH S.r.l.).  
Exemple de visseuse autoalimentée avec application de porte-embouts et embout filetés (avec l'aimable autorisation de MTA TECH S.r.l.).  
Ejemplo de atornillador autoalimentado con aplicación de porta puntas e inserto roscados (gracias a la concesión de MTA TECH S.r.l.).

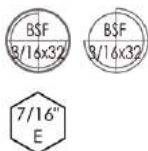

# 2 INSERTI E CHIAVI SPECIALI

BITS AND SPECIAL SETTERS  
EMBOUS ET CLÉS SPÉCIALES  
PUNTAS Y VASOS ESPECIALES

## 61038 PH - BSF 3/16x32

59/61 HRC

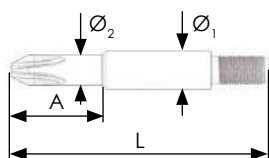

INSERTI BSF 3/16x32 (WITHWORTH) PHILLIPS® PER AVVITATORI AUTOALIMENTATI  
PHILLIPS® BSF 3/16x32 BITS (WITHWORTH) FOR SELF-POWERED DRIVERS  
EMBOUS BSF 3/16x32 (WITHWORTH) PHILLIPS® POUR VISSEUSES AUTOALIMENTÉES  
PUNTAS BSF 3/16x32 (WITHWORTH) PHILLIPS® PARA ATORNILLADORES AUTOALIMENTADOS

**EASYPACK** | sacchetto PVC con Euro-hole • PVC bags with Euro-hole

	L mm	Ø <sub>1</sub> mm	Ø <sub>2</sub> mmxA	PCS.	COD.	€ cad./each
<b>PH1</b>	45	6	5x15	10	61038005	8,570
<b>PH2</b>	45	6		10	61038010	8,570

## 61064 PZ - BSF 3/16x32

59/61 HRC

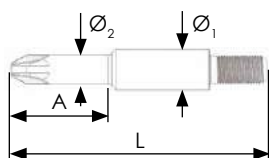

INSERTI BSF 3/16x32 (WITHWORTH) POZIDRIV PER AVVITATORI AUTOALIMENTATI  
POZIDRIV® BSF 3/16x32 BITS (WITHWORTH) FOR SELF-POWERED DRIVERS  
EMBOUS BSF 3/16x32 (WITHWORTH) POZIDRIV® POUR VISSEUSES AUTOALIMENTÉES  
PUNTAS BSF 3/16x32 (WITHWORTH) POZIDRIV® PARA ATORNILLADORES AUTOALIMENTADOS

**EASYPACK** | sacchetto PVC con Euro-hole • PVC bags with Euro-hole

	L mm	Ø <sub>1</sub> mm	Ø <sub>2</sub> mmxA	PCS.	COD.	€ cad./each
<b>PZ1</b>	45	6	5x15	10	61064005	8,570
<b>PZ2</b>	45	6		10	61064010	8,570

## 62008 PORTAINSERTI 1/4"E PER INSERTI BSF 3/16x32

PORTAINSERTI 1/4"E PER INSERTI BSF 3/16x32  
1/4"E BIT-HOLDER FOR BSF 3/16x32 BITS  
PORTE-EMBOUS 1/4"E POUR EMBOUS BSF 3/16x32  
PORTA PUNTAS DE 1/4"E PARA PUNTAS BSF 3/16x32



**EASYPACK** | sacchetto PVC con Euro-hole • PVC bags with Euro-hole

L mm	l mm	Ø mm	PCS.	COD.	€ cad./each
<b>84</b>	15	7	5	62008005	29,500





## 61012 ESAGONO 7/16" RAPIDO

LAME 7/16" RAPIDO ESAGONALI PER AVVITATORI  
QUICK 7/16" HEXAGONAL POWER BITS FOR DRIVERS  
EMBOUS 7/16" RAPIDE HEXAGONALES POUR VISSEUSES  
PUNTAS DE 7/16" RÁPIDO HEXAGONALES PARA ATORNILLADORES

56/58 HRC

**EASYPACK** | sacchetto PVC con Euro-hole • PVC bags with Euro-hole

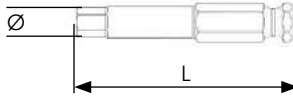

Ø	L mm	PCS.	COD.	€ cad./each
3	70	5	61012005	19,100
4	70	5	61012010	19,100
5	70	5	61012015	19,100
6	70	5	61012025	19,100
8	70	5	61012035	19,100
10	70	5	61012045	19,100

## 62085 PORTAINSERTI 1/2" x 7/16" IMPACT MANDRINO RAPIDO

PORTAINSERTI IMPACT 1/2" PER 7/16" CON MANDRINO DI BLOCCO  
1/2" FOR 7/16" IMPACT BIT-HOLDER WITH CHUCK  
PORTE-EMBOUTS IMPACT 1/2" POUR 7/16" AVEC MANDRIN DE BLOCAGE  
PORTA PUNTAS IMPACT 1/2" PARA 7/16" CON MANDRIL DE BLOQUEO

**EASYPACK** | sacchetto PVC con Euro-hole • PVC bags with Euro-hole

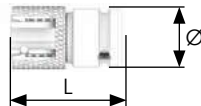

L mm	Ø mm	PCS.	COD.	€ cad./each
45	25	1	62085005	131,300





# 2 INSERTI E CHIAVI SPECIALI

BITS AND SPECIAL SETTERS  
EMBOUS ET CLÉS SPÉCIALES  
PUNTAS Y VASOS ESPECIALES

## 61055 PH - 5/16" RAPIDO

LAME 5/16" RAPIDO PHILLIPS® PER AVVITATORI  
QUICK PHILLIPS® 5/16" POWER BITS FOR DRIVERS  
EMBOUS 5/16" RAPIDE PHILLIPS® POUR VISSEUSES  
PUNTAS DE 5/16" RÁPIDO PHILLIPS® PARA ATORNILLADORES

58/60 HRC

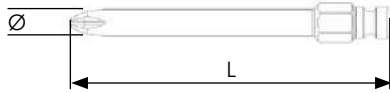

**EASYPACK** | sacchetto PVC con Euro-hole • PVC bags with Euro-hole

	L mm	Ø mm	PCS.	COD.	€ cad./each
PH1	50	4,5	5	61055005	4,960
	75	4,5	5	61055010	5,900
	100	4,5	5	61055015	7,500
	150	4,5	5	61055020	9,110
PH2	50	6	5	61055025	4,960
	75	6	5	61055030	5,900
	100	6	5	61055035	7,500
PH3	150	6	5	61055040	9,110
	50	8	5	61055045	6,430
	75	8	5	61055050	7,230
	100	8	5	61055055	10,200

## 61080 PZ - 5/16" RAPIDO

LAME 5/16" RAPIDO POZIDRIV® PER AVVITATORI  
QUICK POZIDRIV® 5/16" POWER BITS FOR DRIVERS  
EMBOUS 5/16" RAPIDE POZIDRIV® POUR VISSEUSES  
PUNTAS DE 5/16" RÁPIDO POZIDRIV® PARA ATORNILLADORES

58/60 HRC



**EASYPACK** | sacchetto PVC con Euro-hole • PVC bags with Euro-hole

	L mm	Ø mm	PCS.	COD.	€ cad./each
PZ1	50	4,5	5	61080005	4,960
	75	4,5	5	61080010	5,900
	100	4,5	5	61080015	7,500
PZ2	50	6	5	61080020	4,960
	75	6	5	61080025	5,900
	100	6	5	61080030	7,500
PZ3	50	8	5	61080035	6,430
	75	8	5	61080040	7,230
	100	8	5	61080045	10,200

## 61010 ESAGONO 5/16" RAPIDO

LAME 5/16" RAPIDO ESAGONALI PER AVVITATORI  
QUICK 5/16" HEXAGONAL POWER BITS FOR DRIVERS  
EMBOUS 5/16" RAPIDE HEXAGONALES POUR VISSEUSES  
PUNTAS DE 5/16" RÁPIDO HEXAGONALES PARA ATORNILLADORES

58/60 HRC

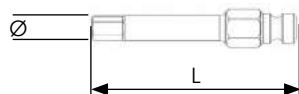

**EASYPACK** | sacchetto PVC con Euro-hole • PVC bags with Euro-hole

	L mm	Ø mm	PCS.	COD.	€ cad./each
2	70	3	5	61010005	9,910
2,5	70	4	5	61010007	9,910
3	70	4	5	61010010	9,910
4	70	5	5	61010015	9,910
5	70	6	5	61010020	9,910
6	70	7	5	61010025	9,910
7	70	8	5	61010030	9,910
8	70	5/16	5	61010035	9,910
9	70	11	5	61010040	9,910
10	70	12	5	61010045	9,910

5/16"

**63008**

## CHIAVI A BUSSOLA ALTA RESISTENZA - 5/16" RAPIDO

56/58 HRC

CHIAVI 5/16" RAPIDO A BUSSOLA NON MAGNETICHE ALTA RESISTENZA  
 QUICK 5/16" NON-MAGNETIC NUT SETTERS HIGH-RESISTANCE  
 DOUILLES 5/16" RAPIDE NON MAGNÉTIQUES HAUTE RÉISTANCE  
 ACOPLAMIENTOS DE 5/16" RÁPIDO NO MAGNÉTICOS DE ALTA RESISTENCIA

**EASYPACK** | sacchetto PVC con Euro-hole • PVC bags with Euro-hole

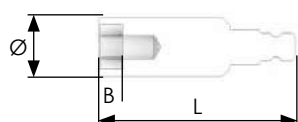

	L mm	Ø mm	B	PCS.	COD.	€ cad./each
<b>7</b>	50	11	4,5	5	63008035	10,500
	75	11	4,5	5	63008040	13,600
	100	11	4,5	5	63008045	15,000
<b>8</b>	50	13	5,5	5	63008050	10,500
	75	13	5,5	5	63008055	13,600
	100	13	5,5	5	63008060	15,000
<b>10</b>	50	15	6,5	5	63008065	11,400
	75	15	6,5	5	63008070	14,700
	100	15	6,5	5	63008075	16,400

**62068**

## ADATTATORI 1/4"E PER LAME 5/16" RAPIDO

ADATTATORE 1/4"E PER LAME 5/16" RAPIDO  
 1/4"E ADAPTER FOR QUICK 5/16" POWER BITS  
 ADAPTATEUR 1/4"E POUR EMBOUTS 5/16" RAPIDE  
 ADAPTADOR DE 1/4"E PARA PUNTAS 5/16" RÁPIDO

**EASYPACK** | sacchetto PVC con Euro-hole • PVC bags with Euro-hole

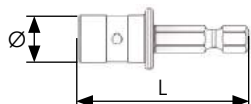

L mm	Ø mm	PCS.	COD.	€ cad./each
46	17	1	62068005	38,200

2



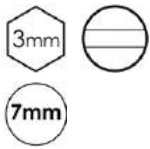

# 2 INSERTI E CHIAVI SPECIALI

BITS AND SPECIAL SETTERS  
EMBOUS ET CLÉS SPÉCIALES  
PUNTAS Y VASOS ESPECIALES

## 61031 PH - 3mm

LAME 3mm (A3) PHILLIPS® PER AVVITATORI  
PHILLIPS® 3mm (A3) POWER BITS FOR DRIVERS  
EMBOUS 3mm (A3) PHILLIPS® POUR VISSÉUSES  
PUNTAS DE 3mm (A3) PHILLIPS® PARA ATORNILLADORES

59/60 HRC

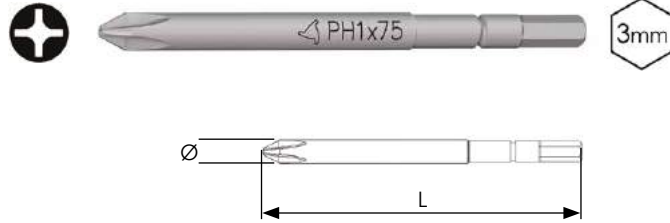

**EASYPACK** | sacchetto PVC con Euro-hole • PVC bags with Euro-hole

	L mm	Ø mm	PCS.	COD.	€ cad./each
<b>PH1</b>	75	4	5	61031005	14,800
<b>PH2</b>	55	5	5	61031010	12,100

## 61040 PH - ATTACCO A SPINA

LAME A SPINA PASSANTE PHILLIPS® PER AVVITATORI  
PHILLIPS® ROUND DRIVE WITH THROUGH HOLE POWER BITS FOR DRIVERS  
EMBOUS TRAVERSANTES PHILLIPS® POUR VISSÉUSES  
PUNTAS AGUJERO PASANTE PHILLIPS® PARA ATORNILLADORES

59/60 HRC

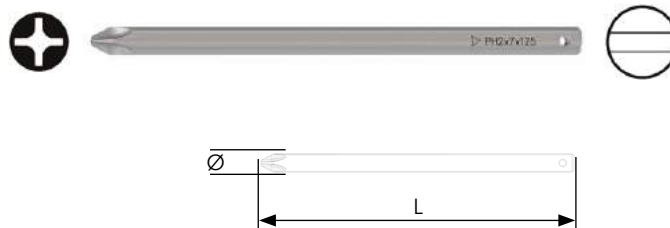

**EASYPACK** | sacchetto PVC con Euro-hole • PVC bags with Euro-hole

	L mm	Ø mm	PCS.	COD.	€ cad./each
<b>PH1</b>	125	4	5	61040005	17,200
	125	4,5	5	61040010	17,200
	125	5	5	61040015	17,200
	125	5,5	5	61040020	17,200
	125	6	5	61040025	17,200
<b>PH2</b>	125	6,5	5	61040030	17,200
	125	7	5	61040035	17,200
	125	8	5	61040040	20,100



### TIPS

Su richiesta realizziamo anche gli adattatori con attacco 1/4" ed innesto alesato. Per avvitatori autoalimentati tipo vegetti.

On request, we also produce adapters with 1/4" attachment and bored coupling. For self-powered screwdrivers.

Nous réalisons sur demande aussi les adaptateurs avec queue 1/4" et raccord fraisé. Pour les visseuses autoalimentées.

Bajo petición también realizamos adaptadores con empalme de 1/4" y con enganche escariado. Para atornilladores autoalimentados.

## 61066 PZ - ATTACCO A SPINA

LAME A SPINA PASSANTE POZIDRIV® PER AVVITATORI  
POZIDRIV® ROUND DRIVE WITH THROUGH HOLE POWER BITS FOR DRIVERS  
EMBOUS TRAVERSANTES POZIDRIV® POUR VISSÉUSES  
PUNTAS AGUJERO PASANTE POZIDRIV® PARA ATORNILLADORES

59/60 HRC

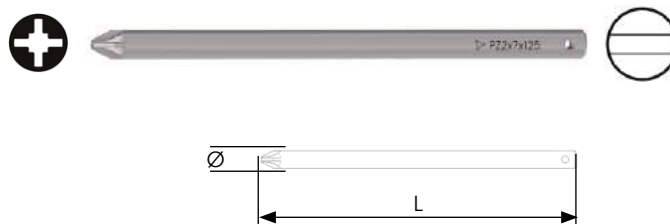

**EASYPACK** | sacchetto PVC con Euro-hole • PVC bags with Euro-hole

	L mm	Ø mm	PCS.	COD.	€ cad./each
<b>PZ1</b>	125	4	5	61066005	17,200
	125	4,5	5	61066010	17,200
	125	5	5	61066015	17,200
	125	5,5	5	61066020	17,200
	125	6	5	61066025	17,200
<b>PZ2</b>	125	6,5	5	61066030	17,200
	125	7	5	61066035	17,200
	125	8	5	61066040	20,100

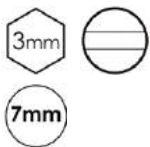

## 61042 PH DOPPIO - D.7

LAME D.7 DOPPIA IMPRONTA PHILLIPS®  
PHILLIPS® D.7 DOUBLE TIP POWER BITS  
EMBOUTS D.7 DOUBLE EMPREINTE PHILLIPS®  
PUNTAS D.7 DOBLE HUELLA PHILLIPS®

58/60 HRC

**EASYPACK** | sacchetto PVC con Euro-hole • PVC bags with Euro-hole

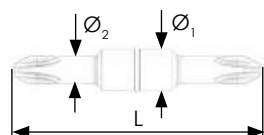

	L mm	Ø <sub>1</sub> mm	Ø <sub>2</sub> mm	PCS.	COD.	€ cad./each
<b>1x1</b>	50	7	4,5	5	61042005	10,800
<b>2x2</b>	50	7		5	61042010	10,800
<b>3x3</b>	50	7		5	61042015	10,800

## 61068 PZ DOPPIO - D.7

LAME D.7 DOPPIA IMPRONTA POZIDRIV®  
POZIDRIV® D.7 DOUBLE TIP POWER BITS  
EMBOUTS D.7 DOUBLE EMPREINTE POZIDRIV®  
PUNTAS D.7 DOBLE HUELLA POZIDRIV®

59/61 HRC

**EASYPACK** | sacchetto PVC con Euro-hole • PVC bags with Euro-hole

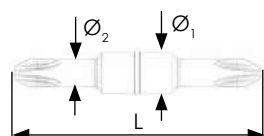

	L mm	Ø <sub>1</sub> mm	Ø <sub>2</sub> mm	PCS.	COD.	€ cad./each
<b>1x1</b>	50	7	4,5	5	61068005	10,800
<b>2x2</b>	50	7		5	61068010	10,800

## 62042 PORTAINSERTI 1/4"E PER INSERTI DOPPI D.7

ADATTATORE 1/4"E PER DOPPI D.7  
1/4"E ADAPTER FOR D.7 DOUBLE  
ADAPTATEUR 1/4"E POUR DOUPLES D.7  
ADAPTADOR DE 1/4"E PARA DOBLES D.7

**EASYPACK** | sacchetto PVC con Euro-hole • PVC bags with Euro-hole

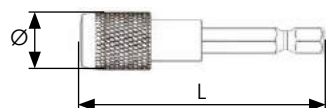

L mm	Ø mm	PCS.	COD.	€ cad./each
54	14	1	62042005	32,200





# 2 INSERTI E CHIAVI SPECIALI

BITS AND SPECIAL SETTERS  
EMBOUS ET CLÉS SPÉCIALES  
PUNTAS Y VASOS ESPECIALES

**63015**

## CHIAVI 1/4"E PER BUSSOLE FILETTATE

CHIAVI 1/4"E AVVITA BUSSOLE  
1/4"E SCREW-IN TOOL FOR COUPLING SLEEVE  
CLÉ 1/4"E POUR DOUILLES FILETÉES  
ADAPTADOR 1/4"E PARA VASOS ROSCADOS

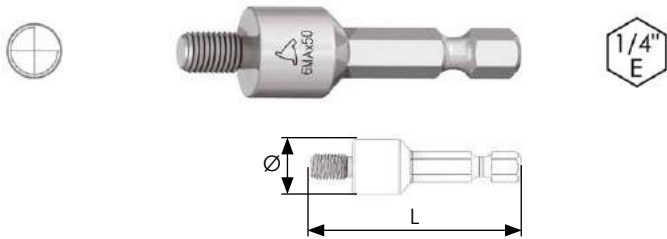

**EASYPACK** | sacchetto PVC con Euro-hole • PVC bags with Euro-hole

⊕	L mm	Ø mm	PCS.	COD.	€ cad./each
4MA	50	10	5	63015005	25,400
5MA	50	10	5	63015010	25,400
6MA	50	10	5	63015015	25,400
8MA	50	12	5	63015020	25,400
10MA	50	14	5	63015025	25,400

**63016**

## CHIAVI 1/4"E PER BUSSOLE FILETTATE

CHIAVI 1/4"E AVVITA BUSSOLE A SGANCIO RAPIDO  
1/4"E QUICK RELEASE SCREW-IN TOOL FOR COUPLING SLEEVE  
CLÉ 1/4"E POUR DOUILLES FILETÉES AVEC DÉCLENCHEMENT RAPIDE  
ADAPTADOR 1/4"E PARA VASOS ROSCADOS CON DESENGANCHE RÁPIDO

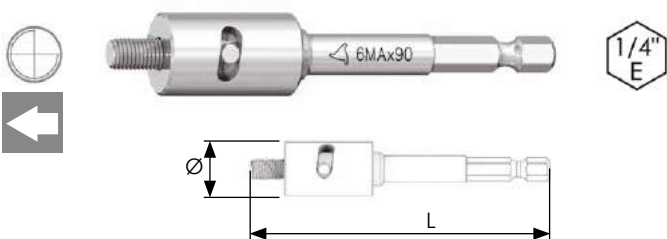

**EASYPACK** | sacchetto PVC con Euro-hole • PVC bags with Euro-hole

⊕	L mm	Ø mm	PCS.	COD.	€ cad./each
4MA	90	16	1	63016005	40,200
5MA	90	16	1	63016010	40,200
6MA	90	16	1	63016015	40,200
8MA	90	16	1	63016020	40,200
10MA	90	16	1	63016025	40,200



### FOCUS ON



- ① In fase di avvitatura la ghiera ruota e si sposta verso la bussola filettata.
- ② In fase di svitamento la ghiera ruota in senso inverso allontanandosi dalla bussola filettata così da liberarla.
- ① In the phase of screwing, the ring nut rotates and moves toward the threaded socket.
- ② In the phase of unscrewing, the ring nut rotates in the opposite direction and moves away from the threaded socket, in order to free it.
- ① Pendant le vissage, la bague tourne et se déplace vers la douille filetée.
- ② Pendant le dévissage, la bague tourne dans le sens contraire en s'éloignant de la douille filetée pour la libérer.
- ① En la fase de atornillado la abrazadera gira y se desplaza hacia la llave tubular roscada.
- ② En la fase de destornillado el cuerpo interno se retrae del tope soltando el prisionero.



**63021**

## CHIAVI 1/4"E PER PRIGIONIERI FILETTATI

CHIAVI 1/4"E AVVITA PRIGIONIERI  
1/4"E INTERNAL TRHEAD INSERTION TOOL  
CLES 1/4"E À FILETAGE INTERNE POUR TIGES FILETÉES  
LLAVES 1/4"E CON ROSCA INTERIOR PARA ESPARRÁGOS

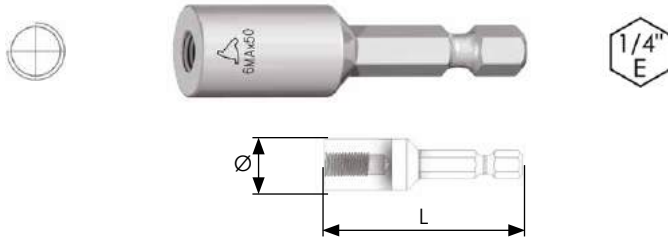
**EASYPACK** | sacchetto PVC con Euro-hole • PVC bags with Euro-hole

⊕	L mm	Ø mm	PCS.	COD.	€ cad./each
5MA	50	10	5	63021005	25,400
6MA	50	12	5	63021010	25,400
8MA	50	14	5	63021015	25,400
10MA	50	16	5	63021020	25,400

**63022**

## CHIAVI 1/4"E PER PRIGIONIERI FILETTATI

CHIAVI 1/4"E AVVITA PRIGIONIERI A SGANCIO RAPIDO  
1/4"E QUICK RELEASE INTERNAL TRHEAD INSERTION TOOL  
CLES 1/4"E À FILETAGE INTERNE POUR TIGES FILETÉES AVEC DÉCLENCHEMENT RAPIDE  
LLAVES 1/4"E CON ROSCA INTERIOR PARA ESPARRÁGOS CON DESENGANCHE RÁPIDO

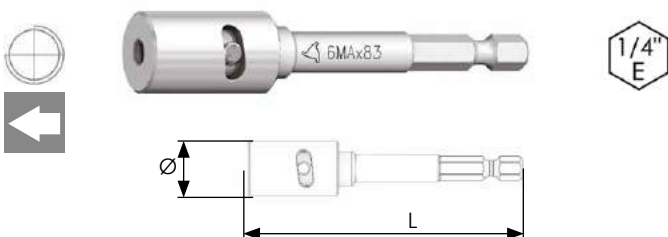
**EASYPACK** | sacchetto PVC con Euro-hole • PVC bags with Euro-hole

⊕	L mm	Ø mm	PCS.	COD.	€ cad./each
5MA	70	16	1	63022005	43,200
6MA	70	16	1	63022010	43,200
7MA	70	16	1	63022015	43,200
8MA	70	16	1	63022020	43,200
10MA	70	16	1	63022025	43,200

**FOCUS ON**

- ① In fase di avvitatura il corpo interno si avvicina al prigioniero bloccandolo in battuta.
- ② In fase di svitamento il corpo interno si ritrae dalla battuta liberando il prigioniero.
- ① In the phase of screwing, the inner body moves towards the captive screw, locking it into place.
- ② In the phase of unscrewing, the inner body withdraws from the stop, freeing the captive screw.
- ① Pendant le vissage, le corps intérieur se rapproche du goujon en le bloquant sur la butée.
- ② Pendant le dévissage, le corps interne se rétracte de la butée en libérant le goujon.
- ① En la fase de atornillado el cuerpo interno se acerca al prisionero bloqueándolo en el tope.
- ② En la fase de destornillado el cuerpo interno se retrae del tope soltando el prisionero.





## 2 INSERTI E CHIAVI SPECIALI

BITS AND SPECIAL SETTERS  
EMBOUS ET CLÉS SPÉCIALES  
PUNTAS Y VASOS ESPECIALES

**62155**

### ADATTATORI PER PUNTE

ADATTATORI 1/4"E PER PUNTE DA TRAPANO  
1/4"E ADAPTERS FOR DRILL BITS  
ADAPTATEUR 1/4 "E POUR FORETS DE PERCEUSE  
ADAPTADORES 1/4"E PARA BROCAS DE TALADRO



**EASYPACK** | sacchetto PVC con Euro-hole • PVC bags with Euro-hole

Ø	L mm	PCS.	COD.	€ cad./each
<b>3</b>	50	5	62155005	<b>33,400</b>
<b>4</b>	50	5	62155010	<b>33,400</b>
<b>5</b>	50	5	62155015	<b>33,400</b>



**63025**

### ADATTATORI PER MASCHI

ADATTATORI 1/4"E PER MASCHI  
1/4" E ADAPERS FOR TAPS  
ADAPTATEUR 1/4 "E POUR TARAUDES  
ADAPTADORES 1/4"E PARA MACHOS DE ROSCAR



**EASYPACK** | sacchetto PVC con Euro-hole • PVC bags with Euro-hole

Ø	L mm	PCS.	COD.	€ cad./each
<b>3M</b>	50	5	63025005	<b>28,300</b>
<b>4M</b>	50	5	63025010	<b>28,300</b>
<b>5M</b>	50	5	63025015	<b>28,300</b>
<b>6M</b>	50	5	63025020	<b>28,300</b>
<b>8M</b>	50	5	63025025	<b>28,300</b>



#### FOCUS ON



#### MASCHIO/TAP

ITEM	DIN352	DIN371	DIN376	DIN374
63025005	M3	M3	M5	M5
63025010	M4	M4	M6	M6
63025015	M5-M8	M5-M6	M8	M8
63025020	M5-M8	M5-M6	M8	M8
63025025		M8		





## 63014 CHIAVI PER CERNIERE ANUBA

CHIAVI 1/4"E PER CERNIERE ANUBA  
1/4"E KEY-LOCKS FOR ANUBA HINGENS  
CLES 1/4"E POUR CHARNIERES ANUBA  
LLAVES 1/4"E PARA BISAGRAS ANUBA

EASYPACK | sacchetto PVC con Euro-hole • PVC bags with Euro-hole

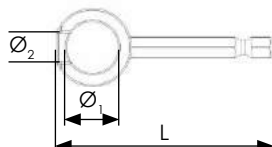

Ø <sub>1</sub> mm	L mm	Ø <sub>2</sub> mm	PCS.	COD.	€ cad./each
9	60	5	5	63014005	33,500
11	62	6	5	63014010	33,500
13	64	8	5	63014015	33,500
14	65	8	5	63014020	33,500



2



Installazione di infissi e coperture con cerniera.  
Installation of windows and doors with hinges.  
Installation des fenêtres avec charnières.  
Instalacion de carpenteria con bisagras.





# 2 INSERTI E CHIAVI SPECIALI

BITS AND SPECIAL SETTERS  
EMBOUTS ET CLÉS SPÉCIALES  
PUNTAS Y VASOS ESPECIALES

## 62151 ADATTATORI 1/4"E PER MANDRINI

ADATTATORI 1/4"E PER MANDRINI, CON VITE SINISTRA DI BLOCCO  
1/4"E ADAPTERS FOR CHUCKS, WITH LEFT BLOCK SCREWS  
ADAPTATEURS 1/4"E POUR MANDRINS, AVEC VIS GAUCHE DE BLOCAGE  
ADAPTADORES 1/4"E PARA MANDRILES, CON TORNILLO IZQUIERDA DE BLOQUEO

**EASYPACK** | sacchetto PVC con Euro-hole • PVC bags with Euro-hole

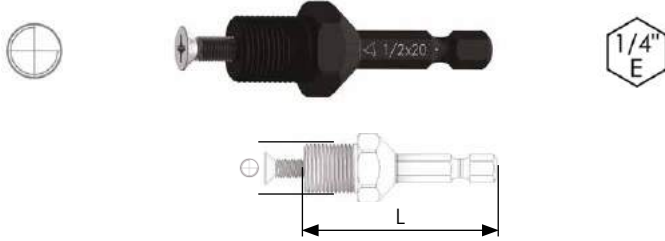

⊕	L mm	PCS.	COD.	€ cad./each
<b>3/8"x24</b>	50	5	62151005	<b>6,430</b>
<b>1/2"x20</b>	50	5	62151010	<b>7,900</b>

## 62152 ADATTATORI SDS-PLUS PER MANDRINI

ADATTATORI SDS-PLUS PER MANDRINI, CON VITE SINISTRA DI BLOCCO  
SDS-PLUSADAPTERS FOR CHUCKS, WITH LEFT BLOCK SCREWS  
ADAPTATEURS SDS-PLUS POUR MANDRINS, AVEC VIS GAUCHE DE BLOCAGE  
ADAPTADORES SDS-PLUS PARA MANDRILES, CON TORNILLO IZQUIERDA DE BLOQUEO

**EASYPACK** | sacchetto PVC con Euro-hole • PVC bags with Euro-hole

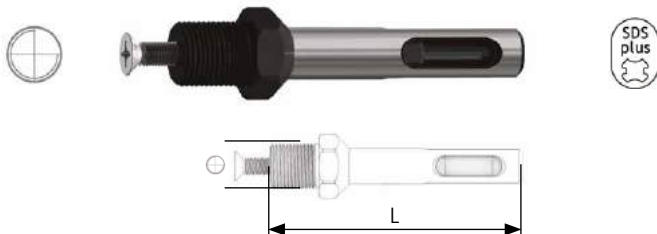

⊕	L mm	PCS.	COD.	€ cad./each
<b>1/2"X20</b>	65	5	62152005	<b>8,710</b>

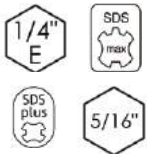

## 62122 ADATTATORI RAPIDO SDS MAX / SDS PLUS®

ADATTATORE SDS-MAX PER PUNTE SDS-PLUS  
 SDS-MAX ADAPTER FOR SDS-PLUS DRILL BITS  
 ADAPTEUR SDS-MAX POUR FORETS SDS-PLUS  
 ADAPTADORES SDS-MAX PARA BROCAS SDS-PLUS

**EASYPACK** | sacchetto PVC con Euro-hole • PVC bags with Euro-hole



L mm	PCS.	COD.	€ cad./each
220	1	62122101	71,600

## 62180 RINVII ANGOLARI 90° PROFESSIONALI PER PUNTE

max 5000 rpm

RINVIO AD ANGOLO 90° CON MANDRINO AUTOSERRANTE PER PUNTE  
 90° ANGLE DRIVER WITH SELF-LOCKING CHUCK FOR DRILL BITS  
 RENVOI D'ANGLE 90° AVEC MANDRIN SANS CLÉ POUR FORETS  
 PORTA BROCAS ANGULAR DE 90° CON MANDRIL DE CIERRE AUTOMÁTICO

**EASYPACK** | sacchetto PVC con Euro-hole • PVC bags with Euro-hole



Ø	L mm	l mm	PCS.	COD.	€ cad./each
1,5-10	155	100	1	62180006	61,600



125 X 200 mm



Le bussole con attacco quadro sono l'utensile utilizzato per l'avvitatura nel settore automotive e della carpenteria pesante. Con gli avvitatori a massa battente è indispensabile, anche per motivi di sicurezza, utilizzare bussole ed accessori IMPACT, mentre negli altri casi possono essere utilizzate bussole ed accessori cromati. In questo capitolo presentiamo entrambe le soluzioni, a completamento delle linee di utensili per avvitatori nell'ottica di un servizio adeguato ed esaustivo per tutta la nostra clientela.

Sockets with square attachment are used for screwing applications in the automotive and heavy carpentry industries. With impact wrenches it is essential, also for safety reasons, to use IMPACT sockets and accessories, while standard sockets and accessories can be used in other cases. In this chapter we present both solutions to complement the range of tools for screwdrivers with a view to provide an adequate and exhaustive service.

Les douilles avec raccord carré sont utilisées pour le vissage dans le secteur d'automobile et la menuiserie lourde. Avec les visseuses à masse battante, il est essentiel, pour des raisons de sécurité également, d'utiliser des douilles et des accessoires IMPACT, tandis que dans d'autres cas des douilles et des accessoires standard peuvent être utilisés. Dans ce chapitre, nous présentons les deux solutions, pour compléter les lignes d'outils pour les visseuses dans l'optique d'un service adéquat et exhaustif.

Los vasos con empalme cuadrado son el utensilio que se emplea para el atornillado en el sector de los automóviles y de la construcción pesada. Con los atomilladores de impacto es indispensable, también por razones de seguridad, usar vasos y accesorios IMPACT, mientras que en los demás casos pueden usarse vasos y accesorios estándares. En este capítulo presentamos las dos soluciones para completar las líneas de utensilios para atornilladores y proporcionar un servicio adecuado y exhaustivo.



# 3

## BUSSOLE E ACCESSORI SOCKETS AND ACCESSORIES DOUILLES ET ACCESSOIRES VASOS Y ACCESORIOS

### BUSSOLE E ACCESSORI **IMPACT**

SOCKETS AND ACCESSORIES **IMPACT** • DOUILLES ET ACCESSOIRES **IMPACT** •  
VASOS Y ACCESORIOS **IMPACT**



 1/4"

p. 279



 3/8"

p. 282



 1/2"

p. 288



 KMA

p. 298



 KMA SETS

p. 301



 KM

p. 302



 KM SETS

p. 305



 3/4"

p. 306



 1"

p. 312



 1-1/2"

p. 316

### BUSSOLE E ACCESSORI **CHROME**

SOCKETS AND ACCESSORIES **CHROME** • DOUILLES ET ACCESSOIRES **CHROME** •  
VASOS Y ACCESORIOS **CHROME**



 1/4"

p. 321



 3/8"

p. 330



 1/2"

p. 340



**ASSORTIMENTI**  
SETS • JEUX • JUEGOS

p. 357



# IMPACT

## BUSSOLE E ACCESSORI IMPACT

IMPACT sockets and accessories

Douilles et accessoires IMPACT

Vasos y accesorios IMPACT

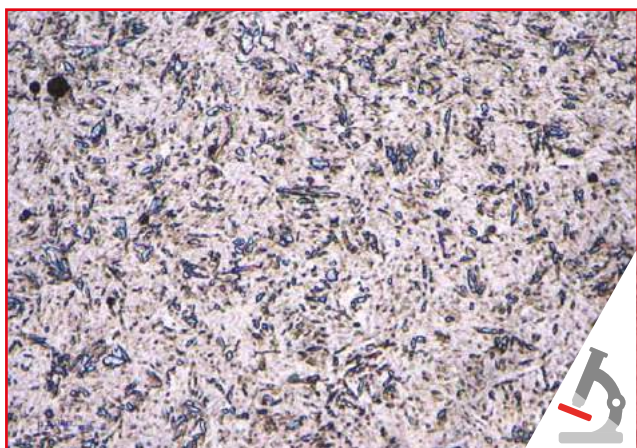
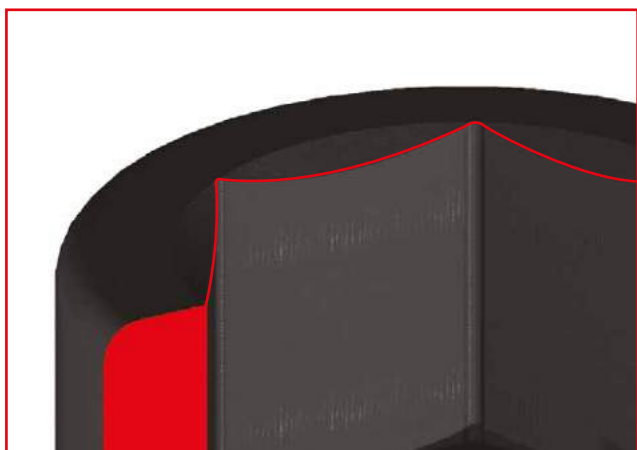

Costruite in acciaio da bonifica al Nickel Cromo Molibdeno, secondo gli standard internazionali. Rivestimento protettivo anti-ossidazione.

Manufactured in Nickel-Chrome-Molybdenum tempered steel, according to international standards. Protective anti-oxidation coating.

Fabriqués en acier de trempe et revenu au nickel-chrome-molybdène, selon les normes internationales. Revêtement de protection anti-oxydation.

Fabricadas con acero templado y revenido de Níquel Cromo Molibdeno, según los estándares internacionales. Recubrimiento protector contra la oxidación.



Spigoli del quadro e dell'esagono arrotondati per distribuire meglio lo sforzo di torsione e minimizzare il rischio di rottura.

Edges of the square and hexagon are rounded to better distribute torsional stress and minimise the risk of breakage.

Les angles du carré et de l'hexagone arrondis répartissent au mieux la contrainte de torsion et minimisent le risque de rupture.

Aristas del cuadrado y del hexágono redondeados para distribuir mejor el esfuerzo de torsión y minimizar el riesgo de ruptura.



Specificatamente indicate per gli usi industriali, con avvitatori ad impulsi e/o a massa battente.

Suitable for industrial use, with pulse and/or impact wrenches.

Particulièrement indiquées pour des utilisations industrielles, avec des visseuses à impulsions et/ou à masse battante.

Indicado en específico para usos industriales, con atornilladores de impulsos y o percutores.



# 64001 IMPACT 1/4"

BUSSOLE IMPACT 1/4" CAVA ESAGONALE  
1/4" HEXAGONAL RECESS IMPACT SOCKETS  
DOUILLES IMPACT 1/4" HEXAGONALE CREUSE  
VASOS IMPACT DE 1/4" CON CAVIDAD HEXAGONAL

40/44 HRC

EASYPACK | sacchetto PVC con Euro-hole • PVC bags with Euro-hole

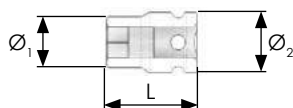

Ø	L mm	Ø <sub>1</sub> mm	Ø <sub>2</sub> mm	PCS.	COD.	€ cad./each
4	23	7,5	13	1	64001005	6,910
4,5	23	8,5	13	1	64001010	6,910
5	23	8,8	13	1	64001020	6,910
5,5	23	9,5	13	1	64001025	6,910
6	23	10	13	1	64001035	6,910
7	23	10,5	13	1	64001045	6,910
8	23	12,5	13	1	64001060	6,910
9	23	14	13	1	64001070	6,910
10	23	15	13	1	64001080	7,500
11	23	16,5	13	1	64001085	7,500
12	23	17	13	1	64001095	7,500
13	23	19	13	1	64001105	7,500
14	23	20	13	1	64001110	8,230
17	23	25	13	1	64001120	6,540

Ø	L mm	Ø <sub>1</sub> mm	Ø <sub>2</sub> mm	PCS.	COD.	€ cad./each
3/16"	23	8,5	13	1	64001015	6,910
7/32"	23	9,5	13	1	64001030	6,910
1/4"	23	10,5	13	1	64001040	6,910
9/32"	23	11,5	13	1	64001050	6,910
5/16"	23	12,5	13	1	64001055	6,910
11/32"	23	14	13	1	64001065	6,910
3/8"	23	15	13	1	64001075	7,500
7/16"	23	16,5	13	1	64001090	7,500
1/2"	23	19	13	1	64001100	7,500
9/16"	23	20	13	1	64001115	8,230



# 64005 IMPACT 1/4" MAGNETICA

BUSSOLE IMPACT 1/4" CAVA ESAGONALE MAGNETICHE  
1/4" HEXAGONAL MAGNETIC RECESS IMPACT SOCKETS  
DOUILLES IMPACT 1/4" HEXAGONALES CREUSES MAGNÉTIQUES  
VASOS IMPACT DE 1/4" CON CAVIDAD HEXAGONAL MAGNÉTICAS

40/44 HRC

EASYPACK | sacchetto PVC con Euro-hole • PVC bags with Euro-hole

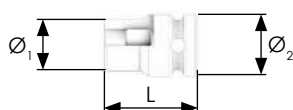

Ø	L mm	Ø <sub>1</sub> mm	Ø <sub>2</sub> mm	PCS.	COD.	€ cad./each
4	23	7,5	13	1	64005005	9,350
4,5	23	8,5	13	1	64005010	9,350
5	23	8,5	13	1	64005015	9,350
5,5	23	9,5	13	1	64005020	9,350
6	23	10	13	1	64005025	9,350
7	23	11,5	13	1	64005030	9,350
8	23	12,5	13	1	64005035	9,350
10	23	15	13	1	64005040	10,200
13	23	19	13	1	64005045	10,200





# 3 BUSSOLE E ACCESSORI

SOCKETS AND ACCESSORIES  
DOUILLES ET ACCESSOIRES  
VASOS Y ACCESORIOS

## 64003 IMPACT 1/4" SERIE LUNGA

BUSSOLE IMPACT 1/4" CAVA ESAGONALE - TIPO LUNGO  
1/4" HEXAGONAL RECESS IMPACT SOCKETS - LONG SERIES  
DOUILLES IMPACT 1/4" HEXAGONALES - CREUSES LONGUES  
VASOS IMPACT DE 1/4" CON CAVIDAD HEXAGONAL - TIPO LARGO

40/44 HRC

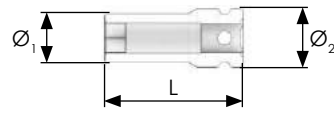

**EASYPACK** | sacchetto PVC con Euro-hole • PVC bags with Euro-hole

Hexagon	L mm	Ø <sub>1</sub> mm	Ø <sub>2</sub> mm	PCS.	COD.	€ cad./each
4	50	7,5	13	1	64003005	9,670
5	50	9	13	1	64003015	9,670
6	50	10	13	1	64003025	9,670
7	50	11,5	13	1	64003035	9,670
8	50	12,5	13	1	64003050	9,670
9	50	14	13	1	64003060	11,200
10	50	15	13	1	64003070	11,900
11	50	16,5	13	1	64003075	11,900
12	50	17	13	1	64003085	11,900
13	50	19	13	1	64003095	12,700
14	50	20	13	1	64003100	13,100



## 64007 IMPACT 1/4" SERIE LUNGA MAGNETE RETRATTILE

BUSSOLE IMPACT 1/4" CAVA ESAGONALE MAGNETE RETRATTILE - TIPO LUNGO  
1/4" HEXAGONAL RECESS IMPACT SOCKETS RETRACTABLE MAGNET - LONG SERIES  
DOUILLES IMPACT 1/4" HEXAGONALES AIMANT RÉTRACTABLE - CREUSES LONGUES  
VASOS IMPACT DE 1/4" CON CAVIDAD HEXAGONAL IMÁN RETRACTIL- TIPO LARGO

40/44 HRC

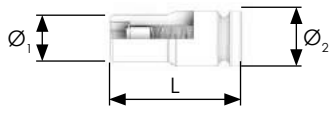

**EASYPACK** | sacchetto PVC con Euro-hole • PVC bags with Euro-hole

Hexagon	L mm	Ø <sub>1</sub> mm	Ø <sub>2</sub> mm	PCS.	COD.	€ cad./each
8	45	12,5	13	1	64007010	29,000
10	45	15	13	1	64007015	29,000

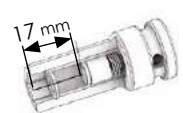





## 62171 PROLUNGHE

PROLUNGA PER BUSSOLE 1/4"  
EXTENSION FOR 1/4" SOCKETS  
RALLONGE POUR DOUILLES 1/4"  
EXTENSION PARA VASOS DE 1/4"

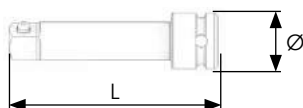
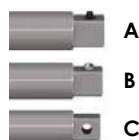

**EASYPACK** | sacchetto PVC con Euro-hole • PVC bags with Euro-hole

L mm	A/B/C	Ø mm	PCS.	COD.	€ cad./each
50	A	13	1	62171005	22,500
100	A	13	1	62171010	27,200
150	A	13	1	62171015	48,300



## 62172 PROLUNGHE SNODATE

PROLUNGA PER BUSSOLE 1/4" SNODATA  
UNIVERSAL JOINT FOR 1/4" SOCKETS  
RALLONGE POUR DOUILLES 1/4" ARTICULÉE  
EXTENSION PARA VASOS DE 1/4" CON ARTICULACIÓN

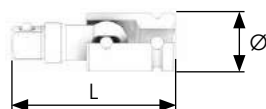
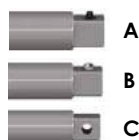

**EASYPACK** | sacchetto PVC con Euro-hole • PVC bags with Euro-hole

L mm	A/B/C	Ø mm	PCS.	COD.	€ cad./each
42	B	13	1	62172005	54,700



## 62115 ADATTATORI PER BUSSOLE 3/8"

ADATTATORE/AUMENTATORE 1/4" PER BUSSOLE DA 3/8"  
1/4" ADAPTER/ENHANCER FOR 3/8" SOCKETS  
ADAPTATEUR/AUGMENTATEUR 1/4" POUR DOUILLES DE 3/8"  
ADAPTADOR/EXTENSOR DE 1/4" PARA VASOS DE 3/8"

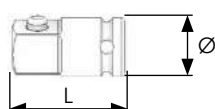
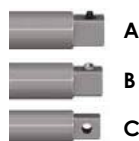

**EASYPACK** | sacchetto PVC con Euro-hole • PVC bags with Euro-hole

L mm	A/B/C	Ø mm	PCS.	COD.	€ cad./each
25	A	13	1	62115005	26,110





# 3 BUSSOLE E ACCESSORI

SOCKETS AND ACCESSORIES  
DOUILLES ET ACCESSOIRES  
VASOS Y ACCESORIOS

**64011**

**IMPACT 3/8"**

BUSSOLE IMPACT 3/8" CAVA ESAGONALE  
3/8" HEXAGONAL RECESS IMPACT SOCKETS  
DOUILLES IMPACT 3/8" HEXAGONALES CREUSES  
VASOS IMPACT DE 3/8" CON CAVIDAD HEXAGONAL

40/44 HRC

**EASYPACK** | sacchetto PVC con Euro-hole • PVC bags with Euro-hole

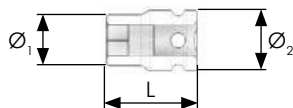

Hexagon	L mm	Ø <sub>1</sub> mm	Ø <sub>2</sub> mm	PCS.	COD.	€ cad./each
6	30	11	19	1	64011005	9,510
7	30	12,5	19	1	64011010	9,510
8	30	14,5	19	1	64011015	9,510
9	30	15	19	1	64011020	9,510
10	30	16	19	1	64011030	9,510
11	30	17,5	19	1	64011035	9,510
12	30	19	19	1	64011045	9,510
13	30	19	22	1	64011055	9,510
14	30	21	22	1	64011060	9,510
15	30	22	22	1	64011070	10,600
16	30	24	22	1	64011080	10,600
17	30	25	22	1	64011085	10,600
18	30	26	22	1	64011095	10,600
19	30	27,5	22	1	64011100	10,600
20	30	28	22	1	64011105	12,700
21	30	30	22	1	64011115	12,700
22	30	32	22	1	64011120	13,600
23	30	32	22	1	64011130	16,000

Hexagon	L mm	Ø <sub>1</sub> mm	Ø <sub>2</sub> mm	PCS.	COD.	€ cad./each
3/8"	30	14,5	19	1	64011025	9,510
7/16"	30	17	19	1	64011040	9,510
1/2"	30	19	19	1	64011050	9,510
9/16"	30	20	22	1	64011065	10,600
5/8"	30	24	22	1	64011075	10,600
11/16"	30	24	22	1	64011090	10,600
13/16"	30	28	22	1	64011110	12,700
7/8"	30	30	22	1	64011125	14,900





# 64013 IMPACT 3/8" SERIE LUNGA

BUSSOLE IMPACT 3/8" CAVA ESAGONALE - TIPO LUNGO  
3/8" HEXAGONAL RECESS IMPACT SOCKETS - LONG SERIES  
DOUILLES IMPACT 3/8" HEXAGONALES - CREUSES LONGUES  
VASOS IMPACT DE 3/8" CON CAVIDAD HEXAGONAL - TIPO LARGO

40/44 HRC

EASYPACK | sacchetto PVC con Euro-hole • PVC bags with Euro-hole

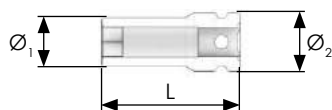

Ø	L mm	Ø <sub>1</sub> mm	Ø <sub>2</sub> mm	PCS.	COD.	€ cad./each
6	65	11	19	1	64013005	17,400
7	65	12,5	19	1	64013010	17,400
8	65	14,5	19	1	64013015	17,400
9	65	15	19	1	64013020	17,400
10	65	16	19	1	64013030	17,400
11	65	17,5	19	1	64013035	17,400
12	65	19	19	1	64013045	17,400
13	65	19	22	1	64013055	18,300
14	65	21	22	1	64013060	19,300
15	65	22	22	1	64013070	19,300
16	65	24	22	1	64013080	19,300
17	65	25	22	1	64013085	19,300
18	65	26	22	1	64013095	19,300
19	65	27,5	22	1	64013100	19,300
20	65	28	22	1	64013105	20,800
21	65	30	22	1	64013115	22,500
22	65	32	22	1	64013120	22,500
23	65	32	22	1	64013130	23,200

Ø	L mm	Ø <sub>1</sub> mm	Ø <sub>2</sub> mm	PCS.	COD.	€ cad./each
3/8"	65	14,5	19	1	64013025	17,400
7/16"	65	17,0	19	1	64013040	17,400
1/2"	65	19,0	19	1	64013050	17,400
9/16"	65	22,0	22	1	64013065	19,300
5/8"	65	24,0	24	1	64013075	19,300
11/16"	65	24,0	24	1	64013090	19,300
13/16"	65	28,0	28	1	64013110	22,500
7/8"	65	30,0	30	1	64013125	23,200





# 3 BUSSOLE E ACCESSORI

SOCKETS AND ACCESSORIES  
DOUILLES ET ACCESSOIRES  
VASOS Y ACCESORIOS

## 64015 IMPACT 3/8" MAGNETICHE

BUSSOLE IMPACT 3/8" CAVA ESAGONALE MAGNETICHE  
3/8" HEXAGONAL MAGNETIC RECESS IMPACT SOCKETS  
DOUILLES IMPACT 3/8" HEXAGONALES CREUSES MAGNÉTIQUES  
VASOS IMPACT DE 3/8" CON CAVIDAD HEXAGONAL MAGNÉTICAS

40/44 HRC

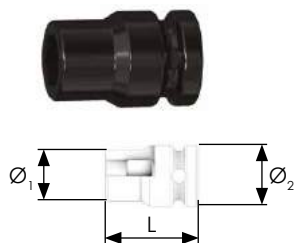

**EASYPACK** | sacchetto PVC con Euro-hole • PVC bags with Euro-hole

Hex	L mm	Ø <sub>1</sub> mm	Ø <sub>2</sub> mm	PCS.	COD.	€ cad./each
7	32	12,5	19	1	64015005	12,900
8	32	14,5	19	1	64015010	12,900
9	32	15	19	1	64015015	12,900
10	32	16	19	1	64015020	12,900
11	32	17,5	19	1	64015025	12,900
12	32	19	19	1	64015030	12,900
13	32	19	22	1	64015035	12,900
17	32	25	22	1	64015040	14,300



## 64017 LUNGA 3/8" MAGNETE RETRATTILE

BUSSOLE IMPACT 3/8" CAVA ESAGONALE MAGNETE RETRATTILE  
3/8" RETRACTABLE MAGNET HEXAGONAL RECESS IMPACT SOCKETS  
DOUILLES IMPACT 3/8" HEXAGONALES CREUSES AIMANT RÉTRACTABLE  
VASOS IMPACT DE 3/8" CON CAVIDAD HEXAGONAL E IMÁN RETRÁCTIL

40/44 HRC

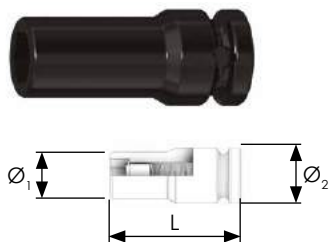

**EASYPACK** | sacchetto PVC con Euro-hole • PVC bags with Euro-hole

Hex	L mm	Ø <sub>1</sub> mm	Ø <sub>2</sub> mm	PCS.	COD.	€ cad./each
7	65	12,5	19	1	64017005	46,400
8	65	14,5	19	1	64017010	46,400
9	65	15	19	1	64017015	46,400
10	50	15	19	1	64017025	35,900
10	65	16	19	1	64017030	46,400
11	65	17,5	19	1	64017035	46,400
12	65	19	19	1	64017045	46,400
13	65	19	22	1	64017055	48,900



## 64125 IMPACT 3/8" PER BULLONI TORX®

BUSSOLE IMPACT 3/8" CAVA PER BULLONI TORX®  
3/8" IMPACT SOCKETS FOR TORX® BOLTS  
DOUILLES IMPACT 3/8" CREUSES POUR BOULONS TORX®  
VASOS IMPACT DE 3/8" CON CAVIDAD PARA TUERCAS TORX®

40/44 HRC



**EASYPACK** | sacchetto PVC con Euro-hole • PVC bags with Euro-hole

Hex	L mm	Ø <sub>1</sub> mm	Ø <sub>2</sub> mm	PCS.	COD.	€ cad./each
E5	32	9	19	1	64125005	9,240
E6	32	10	19	1	64125010	9,240
E7	32	10	19	1	64125015	9,240
E8	32	10,5	19	1	64125020	9,240
E10	32	12,5	19	1	64125025	9,240
E12	32	15	19	1	64125030	9,240
E14	32	17,5	22	1	64125035	9,240
E16	32	19	22	1	64125040	9,240





## 64133 IMPACT 3/8" CON INSERTO TX FISSATO

40/44 HRC

BUSSOLE IMPACT 3/8" CON INSERTO PER VITI TORX® FISSATO  
3/8" IMPACT SOCKETS WITH FIXED BIT FOR TORX® SCREWS  
DOUILLES IMPACT 3/8 "AVEC EMBOUT POUR VIS TORX® FIXE  
VASOS IMPACT DE 3/8" CON PUNTA PARA TORNILLOS TORX® FIJO

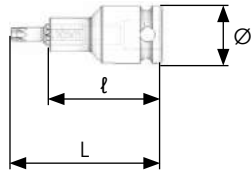

**EASYPACK** | sacchetto PVC con Euro-hole • PVC bags with Euro-hole

	L mm	l mm	Ø mm	PCS.	COD.	€ cad./each
<b>TX10</b>	50	37	19	1	64133005	9,910
<b>TX15</b>	50	37	19	1	64133015	9,910
<b>TX20</b>	50	37	19	1	64133025	9,910
<b>TX25</b>	50	37	19	1	64133035	9,910
<b>TX27</b>	50	37	19	1	64133045	9,910
<b>TX30</b>	50	37	19	1	64133055	9,910
<b>TX40</b>	50	37	19	1	64133065	9,910
<b>TX45</b>	50	37	19	1	64133075	11,200
<b>TX50</b>	50	37	19	1	64133080	11,800



## 64131 IMPACT 3/8" CON INSERTO ESAGONALE FISSATO

40/44 HRC

BUSSOLE IMPACT 3/8" CON INSERTO ESAGONALE FISSATO  
3/8" IMPACT SOCKETS WITH FIXED HEXAGONAL BIT  
DOUILLES IMPACT 3/8 "AVEC EMBOUT HEXAGONAL FIXE  
VASOS IMPACT DE 3/8" CON PUNTA HEXAGONAL FIJO

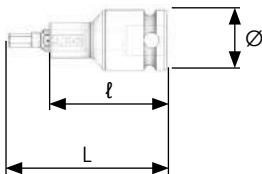

**EASYPACK** | sacchetto PVC con Euro-hole • PVC bags with Euro-hole

	L mm	l mm	Ø mm	PCS.	COD.	€ cad./each
<b>3</b>	50	37	19	1	64131005	9,910
<b>4</b>	50	37	19	1	64131015	9,910
<b>5</b>	50	37	19	1	64131025	9,910
<b>6</b>	50	37	19	1	64131035	9,910
<b>8</b>	50	37	19	1	64131045	9,910
<b>10</b>	50	37	19	1	64131055	9,910



## 64132 IMPACT 3/8" CON INSERTO ESAGONALE SFERICO FISSATO

40/44 HRC

BUSSOLE IMPACT 3/8" CON INSERTO ESAGONALE IMPRONTA TIPO SFERICO FISSATO  
3/8" IMPACT SOCKETS WITH FIXED HEXAGONAL BALL BIT  
DOUILLES IMPACT 3/8 "AVEC EMBOUT HEXAGONAL EMPREINTE SPHERIQUE FIXE  
VASOS IMPACT DE 3/8" CON PUNTA HEXAGONAL HUELLA TIPO ESFERICO FIJO

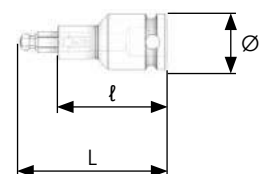

**EASYPACK** | sacchetto PVC con Euro-hole • PVC bags with Euro-hole

	L mm	l mm	Ø mm	PCS.	COD.	€ cad./each
<b>3</b>	50	37	19	1	64132005	10,900
<b>4</b>	50	37	19	1	64132015	10,900
<b>5</b>	50	37	19	1	64132025	10,900
<b>6</b>	50	37	19	1	64132035	10,900





# 3 BUSSOLE E ACCESSORI

SOCKETS AND ACCESSORIES  
DOUILLES ET ACCESSOIRES  
VASOS Y ACCESORIOS

**62181**

## PROLUNGHE

PROLUNGA PER BUSSOLE 3/8"  
EXTENSION FOR 3/8" SOCKETS  
RALLONGE POUR DOUILLES 3/8"  
EXTENSIÓN PARA VASOS DE 3/8"

40/44 HRC

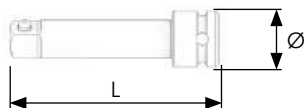
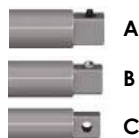

**EASYPACK** | sacchetto PVC con Euro-hole • PVC bags with Euro-hole

L mm	A/B/C	Ø mm	PCS.	COD.	€ cad./each
55	A	19	1	62181005	29,200
75	A	19	1	62181010	14,400
75	B	19	1	62181015	14,400
100	A	19	1	62181025	16,100
100	B	19	1	62181030	16,100
150	A	19	1	62181055	20,100
150	B	19	1	62181060	20,100
200	A	19	1	62181070	23,300



**62183**

## PROLUNGHE SNODATE

PROLUNGA PER BUSSOLE 3/8" SNODATA  
UNIVERSAL JOINT FOR 3/8" SOCKETS  
RALLONGE POUR DOUILLES 3/8" ARTICULÉE  
EXTENSIÓN PARA VASOS DE 3/8" CON ARTICULACIÓN

40/44 HRC

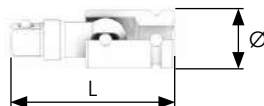
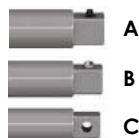

**EASYPACK** | sacchetto PVC con Euro-hole • PVC bags with Euro-hole

L mm	A/B/C	Ø mm	PCS.	COD.	€ cad./each
50	C	19	1	62183005	37,800
58	A	19	1	62183010	59,800



**62184**

## PROLUNGHE SNODATE CON BLOCCO

PROLUNGA PER BUSSOLE 3/8" SNODATA CON BLOCCO  
UNIVERSAL EXTENSION FOR 3/8" SOCKETS WITH LOCK  
RALLONGE POUR DOUILLES 3/8" ARTICULÉE AVEC BLOCAGE  
EXTENSIÓN PARA VASOS DE 3/8" CON ARTICULACIÓN Y BLOQUEO

40/44 HRC

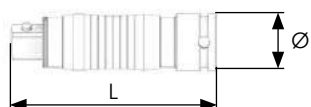
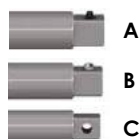

**EASYPACK** | sacchetto PVC con Euro-hole • PVC bags with Euro-hole

L mm	A/B/C	Ø mm	PCS.	COD.	€ cad./each
90	B	19	1	62184005	13,300

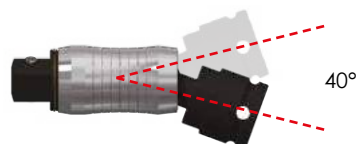



## 62182 PROLUNGHE SGANCIO RAPIDO

PROLUNGA PER BUSSOLE 3/8" A SGANCIO RAPIDO  
EXTENSION FOR 3/8" SOCKETS WITH QUICK RELEASE  
RALLONGE POUR DOUILLES 3/8" À DÉCLENCHEMENT RAPIDE  
EXTENSIÓN PARA VASOS DE 3/8" CON DESENGANCHE RÁPIDO

40/44 HRC

EASYPACK | sacchetto PVC con Euro-hole • PVC bags with Euro-hole



L mm	A/B/C	Ø mm	PCS.	COD.	€ cad./each
46	B	20	1	62182005	115,200

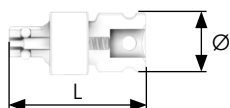
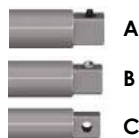

## 62104 RIDUZIONI PER BUSSOLE 1/4"

RIDUZIONE 3/8" PER BUSSOLE DA 1/4"  
3/8" REDUCTION FOR 1/4" SOCKETS  
RÉDUCTION 3/8" POUR DOUILLES DE 1/4"  
REDUCTOR DE 3/8" PARA VASOS DE 1/4"

40/44 HRC

EASYPACK | sacchetto PVC con Euro-hole • PVC bags with Euro-hole



L mm	A/B/C	Ø mm	PCS.	COD.	€ cad./each
32	A	19	1	62104005	34,385
32	B	19	1	62104010	34,385

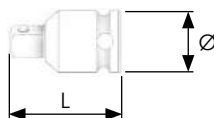
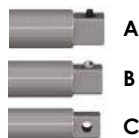

## 62124 ADATTATORI PER BUSSOLE 1/2"

ADATTATORE/AUMENTATORE 3/8" PER BUSSOLE DA 1/2"  
3/8" ADAPTER/ENHANCER FOR 1/2" SOCKETS  
ADAPTATEUR/AUGMENTATEUR 3/8" POUR DOUILLES DE 1/2"  
ADAPTADOR/EXTENSOR DE 3/8" PARA VASOS DE 1/2"

40/44 HRC

EASYPACK | sacchetto PVC con Euro-hole • PVC bags with Euro-hole



L mm	A/B/C	Ø mm	PCS.	COD.	€ cad./each
33	C	22	1	62124005	20,500
38	B	22	1	62124010	23,600

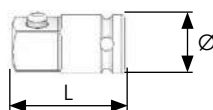
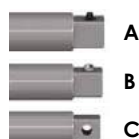



# 3 BUSSOLE E ACCESSORI

SOCKETS AND ACCESSORIES  
DOUILLES ET ACCESSOIRES  
VASOS Y ACCESORIOS

**64031**

**IMPACT 1/2"**

BUSSOLE IMPACT 1/2" CAVA ESAGONALE  
1/2" HEXAGONAL RECESS IMPACT SOCKETS  
DOUILLES IMPACT 1/2" HEXAGONALES CREUSES  
VASOS IMPACT DE 1/2" CON CAVIDAD HEXAGONAL

40/44 HRC

**EASYPACK** | sacchetto PVC con Euro-hole • PVC bags with Euro-hole

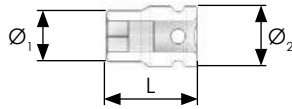

	L mm	Ø <sub>1</sub> mm	Ø <sub>2</sub> mm	PCS.	COD.	€ cad./each
8	38	15	25	1	64031005	10,400
9	38	16	25	1	64031010	10,400
10	38	17	25	1	64031020	10,400
11	38	19	25	1	64031025	10,400
12	38	20	25	1	64031035	10,400
13	38	21	25	1	64031045	10,400
14	38	22	25	1	64031050	10,400
15	38	24	30	1	64031060	11,500
16	38	25	30	1	64031070	11,500
17	38	26	30	1	64031075	11,500
18	38	27,5	30	1	64031085	11,500
19	38	27,5	30	1	64031090	11,500
20	38	30	30	1	64031095	13,800
21	38	30	30	1	64031105	13,800
22	38	32	30	1	64031110	14,700
23	38	32	30	1	64031120	15,900
24	45	25	30	1	64031130	17,300
25	45	25	30	1	64031135	17,300
26	50	38	30	1	64031145	18,500
27	50	38	30	1	64031150	21,200
28	50	40	30	1	64031155	22,100
29	50	41	30	1	64031165	22,100
30	50	41	30	1	64031170	24,800
31	50	44	30	1	64031175	24,800
32	50	44	30	1	64031185	24,800
33	50	45	30	1	64031190	25,100
34	46	49	35	1	64031200	29,000
35	50	49	38	1	64031205	34,700
36	50	49	35	1	64031210	34,700
37	50	52	38	1	64031220	37,400
38	50	52	38	1	64031225	39,000

	L mm	Ø <sub>1</sub> mm	Ø <sub>2</sub> mm	PCS.	COD.	€ cad./each
3/8"	38	16	25	1	64031015	10,400
7/16"	38	18	25	1	64031030	10,400
1/2"	38	20	25	1	64031040	10,400
9/16"	38	22	25	1	64031055	10,400
5/8"	38	25	25	1	64031065	11,500
11/16"	38	25	25	1	64031080	11,500
13/16"	38	30	30	1	64031100	13,800
7/8"	38	32	30	1	64031115	14,700
15/16"	38	25	30	1	64031125	17,300
1"	38	25	30	1	64031140	18,500
1,1/8"	40	38	30	1	64031160	22,100
1,1/4"	40	44	35	1	64031180	24,800
1,5/16"	43	45	35	1	64031195	29,000
1,7/16"	50	49	38	1	64031215	37,400







# 64033 IMPACT 1/2" SERIE LUNGA

BUSSOLE IMPACT 1/2" CAVA ESAGONALE - TIPO LUNGO  
1/2" HEXAGONAL RECESS IMPACT SOCKETS - LONG SERIES  
DOUILLES IMPACT 1/2" HEXAGONALES - CREUSES LONGUES  
VASOS IMPACT DE 1/2" CON CAVIDAD HEXAGONAL - TIPO LARGO

40/44 HRC

EASYPACK | sacchetto PVC con Euro-hole • PVC bags with Euro-hole

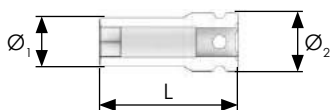

Ø	L mm	Ø <sub>1</sub> mm	Ø <sub>2</sub> mm	PCS.	COD.	€ cad./each
8	80	15	25	1	64033005	18,800
9	80	16	25	1	64033010	18,800
10	80	17	25	1	64033020	18,800
11	80	19	25	1	64033025	18,800
12	80	20	25	1	64033035	18,800
13	80	21	25	1	64033045	19,900
14	80	22	25	1	64033050	19,900
15	80	24	30	1	64033060	20,900
16	80	25	30	1	64033070	20,900
17	80	26	30	1	64033075	20,900
18	80	27,5	30	1	64033085	20,900
19	80	27,5	30	1	64033090	20,900
20	80	30	30	1	64033095	22,600
21	80	30	30	1	64033105	24,500
22	80	32	30	1	64033110	24,500
23	80	32	30	1	64033120	25,300
24	80	25	30	1	64033130	26,600
25	80	25	30	1	64033135	30,000
26	80	38	30	1	64033145	30,000
27	80	38	30	1	64033150	30,000
28	80	40	30	1	64033155	33,000
29	80	41	30	1	64033165	39,400
30	80	41	30	1	64033170	39,400
31	80	44	30	1	64033175	41,700
32	80	44	30	1	64033185	41,700
33	80	45	30	1	64033190	43,800
34	80	49	35	1	64033200	43,800
35	80	49	38	1	64033205	48,900
36	80	49	35	1	64033210	48,900
37	80	52	38	1	64033220	53,900
38	80	52	38	1	64033225	53,900

Ø	L mm	Ø <sub>1</sub> mm	Ø <sub>2</sub> mm	PCS.	COD.	€ cad./each
3/8"	80	16,0	22	1	64033015	18,800
7/16"	80	18,0	22	1	64033030	18,800
1/2"	80	20,0	22	1	64033040	19,900
9/16"	80	22,0	25	1	64033055	19,900
5/8"	80	25,0	25	1	64033065	20,900
11/16"	80	25,0	25	1	64033080	20,900
13/16"	80	30,0	30	1	64033100	22,600
7/8"	80	32,0	30	1	64033115	25,300
15/16"	80	35,0	30	1	64033125	26,600
1"	80	35,0	30	1	64033140	30,000
1.1/8"	80	38,0	30	1	64033160	33,000
1.1/4"	80	44,0	35	1	64033180	41,700
1.5/16"	80	45,0	35	1	64033195	43,800
1.7/16"	80	49,0	38	1	64033215	53,900





# 3 BUSSOLE E ACCESSORI

SOCKETS AND ACCESSORIES  
DOUILLES ET ACCESSOIRES  
VASOS Y ACCESORIOS

## 64035 IMPACT 1/2" MAGNETICA

BUSSOLE IMPACT 1/2" MAGNETICHE CAVA ESAGONALE  
1/2" HEXAGONAL RECESS IMPACT SOCKETS  
DOUILLES IMPACT 1/2" HEXAGONALES CREUSES MAGNÉTIQUES  
VASOS IMPACT DE 1/2" CON CAVIDAD HEXAGONAL MAGNÉTICAS

40/44 HRC

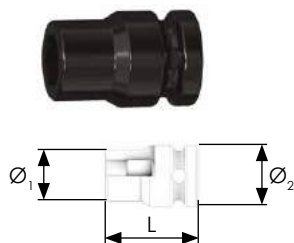

**EASYPACK** | sacchetto PVC con Euro-hole • PVC bags with Euro-hole

●	L mm	Ø <sub>1</sub> mm	Ø <sub>2</sub> mm	PCS.	COD.	€ cad./each
10	38	17	25	1	64035005	14,000
12	38	20	25	1	64035010	14,000
13	38	21	25	1	64035015	14,000
15	38	24	25	1	64035020	15,600
17	38	26	30	1	64035025	15,600
19	38	27,5	30	1	64035030	15,600
20	38	30	30	1	64035035	18,600
22	38	32	30	1	64035040	19,800
24	45	35	30	1	64035045	23,300



## 64040 IMPACT 1/2" PARETI SOTTILI

BUSSOLE IMPACT 1/2" CAVA ESAGONALE - PARETI SOTTILI  
1/2" HEXAGONAL RECESS IMPACT SOCKETS - THIN WALLS  
DOUILLES IMPACT 1/2" HEXAGONALES - PAREIS FINES  
VASOS IMPACT DE 1/2" CON CAVIDAD HEXAGONAL - PAREDES FINAS

40/44 HRC

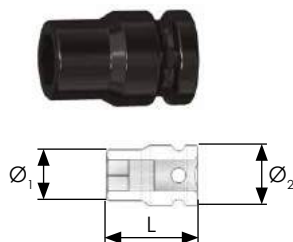

**EASYPACK** | sacchetto PVC con Euro-hole • PVC bags with Euro-hole

●	L mm	Ø <sub>1</sub> mm	Ø <sub>2</sub> mm	PCS.	COD.	€ cad./each
13	38	20,5	25	1	64040005	14,500
14	38	21,5	25	1	64040010	14,500
15	38	23,5	30	1	64040020	14,500
16	38	24,5	30	1	64040030	16,100
17	38	25	30	1	64040035	16,100
18	38	25	30	1	64040045	16,100
19	38	27	30	1	64040050	16,100
20	38	28	30	1	64040055	20,200
21	38	29,5	30	1	64040065	20,700
22	38	30	30	1	64040070	21,200
23	38	31,5	30	1	64040080	22,800
24	38	33	30	1	64040090	24,900



## 64126 IMPACT 1/2" PER BULLONI TORX®

BUSSOLE IMPACT 1/2" PER BULLONI TORX®  
1/2" IMPACT SOCKETS FOR TORX® BOLTS  
DOUILLES IMPACT 1/2" POUR BOULONS TORX®  
VASOS IMPACT DE 1/2" PARA TUERCAS TORX®

40/44 HRC



**EASYPACK** | sacchetto PVC con Euro-hole • PVC bags with Euro-hole

★	L mm	Ø <sub>1</sub> mm	Ø <sub>2</sub> mm	PCS.	COD.	€ cad./each
E10	38	15	25	1	64126005	11,900
E11	38	15,5	25	1	64126010	11,900
E12	38	16	25	1	64126015	11,900
E14	38	18,5	25	1	64126020	11,900
E16	38	20	25	1	64126025	11,900
E18	38	22	25	1	64126030	11,900
E20	38	25	30	1	64126035	15,400
E22	45	26,5	30	1	64126040	15,400
E24	45	28,5	30	1	64126045	15,400





## 64136 IMPACT 1/2" CON INSERTO TX FISSATO

40/44 HRC

BUSSOLE IMPACT 1/2" CON INSERTO PER VITI TORX® FISSATO  
1/2" IMPACT SOCKETS WITH FIXED BIT FOR TORX® SCREWS  
DOUILLES IMPACT 1/2 "AVEC EMBOUT POUR VIS TORX® FIXE  
VASOS IMPACT DE 1/2" CON PUNTA PARA TORNILLOS TORX® FIJO

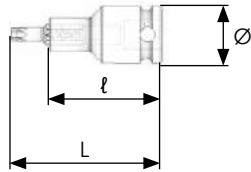

**EASYPACK** | sacchetto PVC con Euro-hole • PVC bags with Euro-hole

	L mm	l mm	Ø mm	PCS.	COD.	€ cad./each
<b>TX20</b>	55	32	25	1	64136005	24,600
<b>TX25</b>	55	32	25	1	64136010	24,600
<b>TX27</b>	55	32	25	1	64136015	24,600
<b>TX30</b>	55	32	25	1	64136020	24,600
<b>TX40</b>	55	32	25	1	64136025	24,600
<b>TX45</b>	55	32	25	1	64136030	24,600
<b>TX50</b>	55	32	25	1	64136035	24,600
<b>TX55</b>	55	32	25	1	64136040	25,900



## 64135 IMPACT 1/2" CON INSERTO ESAGONALE FISSATO

40/44 HRC

BUSSOLE IMPACT 1/2" CON INSERTO ESAGONALE FISSATO  
1/2" IMPACT SOCKETS WITH FIXED HEXAGONAL BIT  
DOUILLES IMPACT 1/2 "AVEC EMBOUT HEXAGONAL FIXE  
VASOS IMPACT DE 1/2" CON PUNTA HEXAGONAL FIJO

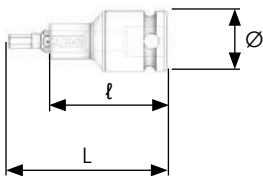

**EASYPACK** | sacchetto PVC con Euro-hole • PVC bags with Euro-hole

	L mm	l mm	Ø mm	PCS.	COD.	€ cad./each
<b>5</b>	55	32	25	1	64135005	24,300
<b>6</b>	55	32	25	1	64135010	24,300
<b>8</b>	55	32	25	1	64135020	24,300
<b>10</b>	55	32	25	1	64135025	24,800





# 3 BUSSOLE E ACCESSORI

SOCKETS AND ACCESSORIES  
DOUILLES ET ACCESSOIRES  
VASOS Y ACCESORIOS

## 64183 IMPACT 1/2" CON INSERTO TX

BUSSOLE IMPACT 1/2" CON INSERTO PER VITI TORX® ESTRAIBILE  
1/2" IMPACT SOCKETS WITH EXTRACTABLE BIT FOR TORX® SCREWS  
DOUILLES IMPACT 1/2 "AVEC EMBOUT POUR VIS TORX® EXTRAÏBLE  
VASOS IMPACT DE 1/2" CON PUNTA PARA TORNILLOS TORX® EXTRAÏBLE

40/44 HRC

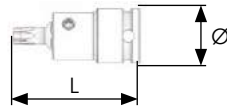

**EASYPACK** | sacchetto PVC con Euro-hole • PVC bags with Euro-hole

	L mm	Ø mm	PCS.	COD.	€ cad./each
<b>TX30</b>	54	25	1	64183005	18,300
<b>TX40</b>	54	25	1	64183010	18,300
<b>TX50</b>	57	25	1	64183015	19,600
<b>TX55</b>	57	25	1	64183020	23,200
<b>TX60</b>	57	30	1	64183025	23,200
<b>TX70</b>	57	30	1	64183030	50,700



## 64181 IMPACT 1/2" CON INSERTO ESAGONALE

BUSSOLE IMPACT 1/2" CON INSERTO ESAGONALE ESTRAIBILE  
1/2" IMPACT SOCKETS WITH EXTRACTABLE HEXAGONAL BIT  
DOUILLES IMPACT 1/2 "AVEC EMBOUT HEXAGONAL EXTRAÏBLE  
VASOS IMPACT DE 1/2" CON PUNTA HEXAGONAL EXTRAÏBLE

40/44 HRC

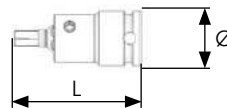

**EASYPACK** | sacchetto PVC con Euro-hole • PVC bags with Euro-hole

	L mm	Ø mm	PCS.	COD.	€ cad./each
<b>5</b>	54	25	1	64181005	17,000
<b>6</b>	54	25	1	64181010	17,000
<b>8</b>	57	25	1	64181015	17,000
<b>10</b>	57	30	1	64181020	22,500
<b>12</b>	57	30	1	64181025	22,500
<b>14</b>	57	30	1	64181030	22,500
<b>17</b>	57	30	1	64181035	31,400
<b>19</b>	75	30	1	64181040	31,400
<b>22</b>	75	30	1	64181045	31,400



## 64184 INSERTI TX PER BUSSOLE IMPACT 1/2"

INSERTI PER VITI TORX® DI RICAMBIO PER BUSSOLE  
TORX® SCREWS SPARE BITS FOR SOCKETS  
EMBOUTS POUR VIS TORX® DE RECHANGE POUR DOUILLES  
PUNTAS PARA TORNILLOS TORX® DE RECAMBIO PARA VASOS

40/44 HRC

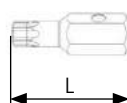

**EASYPACK** | sacchetto PVC con Euro-hole • PVC bags with Euro-hole

	L mm	E	PCS.	COD.	€ cad./each
<b>TX30</b>	32	11	1	64184005	5,980
<b>TX40</b>	32	11	1	64184010	5,980
<b>TX50</b>	35	11	1	64184015	7,230
<b>TX55</b>	35	16	1	64184020	7,230
<b>TX60</b>	35	16	1	64184025	7,230
<b>TX70</b>	35	16	1	64184030	34,700



## 64182 INSERTI ESAGONALI PER BUSSOLE IMPACT 1/2"

INSERTI ESAGONALI DI RICAMBIO PER BUSSOLE  
HEXAGONAL SPARE BITS FOR SOCKETS  
EMBOUTS & PANS DE RECHANGE POUR DOUILLES  
PUNTAS HEXAGONALES DE RECAMBIO PARA VASOS

40/44 HRC

**EASYPACK** | sacchetto PVC con Euro-hole • PVC bags with Euro-hole

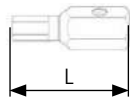

Ø	L mm	E	PCS.	COD.	€ cad./each
5	32	11	1	64182005	4,640
6	32	11	1	64182010	4,640
8	35	11	1	64182015	4,640
10	35	16	1	64182020	6,590
12	35	16	1	64182025	6,590
14	35	16	1	64182030	6,590
17	51	22	1	64182035	11,600
19	51	22	1	64182040	11,600
22	51	22	1	64182070	11,600

## 64185 BUSSOLE IMPACT 1/2" PER INSERTI

BUSSOLE IMPACT 1/2" PORTA INSERTI, CON GRANO  
1/2" IMPACT SOCKETS BIT-HOLDER, WITH GRAIN  
DOUILLES IMPACT 1/2 "AVEC PORTE-EMBOUTS AVEC GOUJON  
VASOS IMPACT DE 1/2" PORTA PUNTA CON MUESCA DE CENTRAJE

40/44 HRC

**EASYPACK** | sacchetto PVC con Euro-hole • PVC bags with Euro-hole

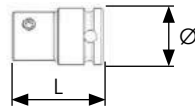

Ø	L mm	Ø mm	PCS.	COD.	€ cad./each
11	35	25	1	64185005	12,400
16	35	30	1	64185010	15,900
22	40	30	1	64185015	19,700



## 64137 IMPACT 1/2" INTEGRALE ESAGONO MASCHIO

BUSSOLE IMPACT 1/2" ESAGONO MASCHIO INTEGRALI  
1/2" IMPACT SOCKETS INTEGRAL MALE HEXAGON  
DOUILLES IMPACT 1/2" HEXAGONALES MÂLES INTÉGRALES  
VASOS IMPACT DE 1/2" HEXAGONALES CON MACHO INTEGRALES

40/44 HRC

**EASYPACK** | sacchetto PVC con Euro-hole • PVC bags with Euro-hole

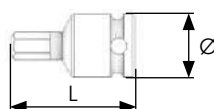

Ø	L mm	Ø mm	PCS.	COD.	€ cad./each
5	40	25	1	64137005	15,400
6	40	25	1	64137010	15,400
7	40	25	1	64137020	15,400
8	40	25	1	64137030	15,400
10	40	25	1	64137045	15,400
12	40	30	1	64137060	15,400
14	45	30	1	64137075	15,400
17	45	30	1	64137100	15,400
19	45	30	1	64137110	15,400





# 3 BUSSOLE E ACCESSORI

SOCKETS AND ACCESSORIES  
DOUILLES ET ACCESSOIRES  
VASOS Y ACCESORIOS

## 62191 PROLUNGHE

PROLUNGA PER BUSSOLE 1/2"  
EXTENSION FOR 1/2" SOCKETS  
RALLONGE POUR DOUILLES 1/2"  
EXTENSION PARA VASOS DE 1/2"

40/44 HRC

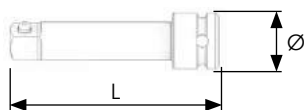
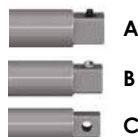

**EASYPACK** | sacchetto PVC con Euro-hole • PVC bags with Euro-hole

L mm	A/B/C	Ø mm	PCS.	COD.	€ cad./each
75	C	30	1	62191015	19,900
75	A	30	1	62191005	26,000
75	B	30	1	62191010	27,600
125	C	30	1	62191030	24,400
125	A	30	1	62191020	31,600
125	B	30	1	62191025	31,900
150	A	30	1	62191035	39,700
200	A	30	1	62191040	52,800
250	C	30	1	62191055	29,200
250	A	30	1	62191045	37,400
250	B	30	1	62191050	37,400

## 62193 PROLUNGHE SNODATE

PROLUNGA PER BUSSOLE 1/2" SNODATA  
UNIVERSAL JOINT FOR 1/2" SOCKETS  
RALLONGE POUR DOUILLES 1/2" ARTICULÉE  
EXTENSION PARA VASOS DE 1/2" CON ARTICULACIÓN

40/44 HRC

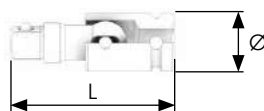
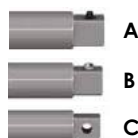

**EASYPACK** | sacchetto PVC con Euro-hole • PVC bags with Euro-hole

L mm	A/B/C	Ø mm	PCS.	COD.	€ cad./each
58	C	30	1	62193005	43,800
58	A	30	1	62193010	57,000
58	B	30	1	62193015	57,000

## 62194 PROLUNGHE SNODATE CON BLOCCO

PROLUNGA PER BUSSOLE 1/2" SNODATA CON BLOCCO  
UNIVERSAL JOINT FOR 1/2" SOCKETS WITH LOCK  
RALLONGE POUR DOUILLES 1/2" ARTICULÉE AVEC BLOCAGE  
EXTENSION PARA VASOS DE 1/2" CON ARTICULACIÓN Y BLOQUEO

40/44 HRC

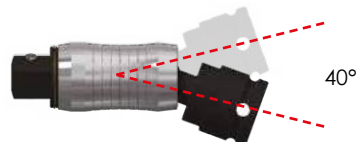
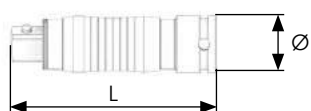
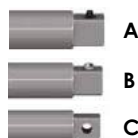

**EASYPACK** | sacchetto PVC con Euro-hole • PVC bags with Euro-hole

L mm	A/B/C	Ø mm	PCS.	COD.	€ cad./each
95	B	30	1	62194005	26,300



# 62192 PROLUNGHE SGANCIO RAPIDO

PROLUNGA PER BUSSOLE 1/2" A SGANCIO RAPIDO  
EXTENSION FOR 1/2" SOCKETS WITH QUICK RELEASE  
RALLONGE POUR DOUILLES 1/2" À DÉCLENCHEMENT RAPIDE  
EXTENSIÓN PARA VASOS DE 1/2" CON DESENGANCHE RÁPIDO

40/44 HRC

**EASYPACK** | sacchetto PVC con Euro-hole • PVC bags with Euro-hole



L mm	A/B/C	Ø mm	PCS.	COD.	€ cad./each
60	B	20	1	62192005	166,100

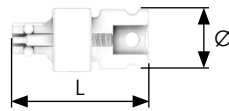
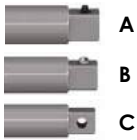

# 62197 PROLUNGHE A CRICCHETTO

PROLUNGA A CRICCHETTO RVERSIBILE PER BUSSOLE 1/2"  
EXTENSION FOR 1/2" SOCKETS WITH REVERSIBLE RATCHET  
RALLONGE POUR DOUILLES 1/2" À CLIQUET RÉVERSIBLE  
EXTENSIÓN PARA VASOS DE 1/2" CON CARRACA REVERSIBLE

40/44 HRC

**EASYPACK** | sacchetto PVC con Euro-hole • PVC bags with Euro-hole



L mm	A/B/C	Ø mm	PCS.	COD.	€ cad./each
65	B	30	1	62197005	30,600

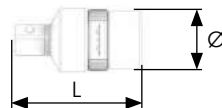
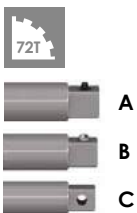



# 3 BUSSOLE E ACCESSORI

SOCKETS AND ACCESSORIES  
DOUILLES ET ACCESSOIRES  
VASOS Y ACCESORIOS

## 62116 RIDUZIONI PER BUSSOLE 3/8"

RIDUZIONE 1/2" PER BUSSOLE DA 3/8"  
1/2" REDUCTION FOR 3/8" SOCKETS  
RÉDUCTION 1/2" POUR DOUILLES DE 3/8"  
REDUCTOR DE 1/2" PARA VASOS DE 3/8"

40/44 HRC

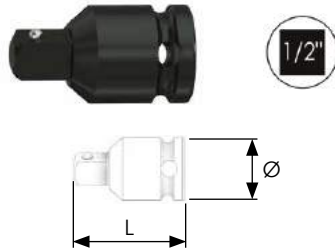
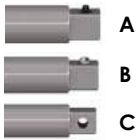

**EASYPACK** | sacchetto PVC con Euro-hole • PVC bags with Euro-hole

L mm	A/B/C	Ø mm	PCS.	COD.	€ cad./each
38	A	25	1	62116005	27,100
38	B	25	1	62116010	27,100
38	C	25	1	62116015	20,000
75	A	25	1	62116020	27,600
150	B	25	1	62116025	40,800



## 62135 ADATTATORI PER BUSSOLE 3/4"

ADATTATORE/AUMENTATORE 1/2" PER BUSSOLE DA 3/4"  
1/2" ADAPTER/ENHANCER FOR 3/4" SOCKETS  
ADAPTATEUR/AUGMENTATEUR 1/2" POUR DOUILLES DE 3/4"  
ADAPTADOR/EXTENSOR DE 1/2" PARA VASOS DE 3/4"

40/44 HRC

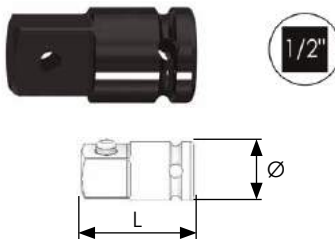
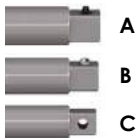

**EASYPACK** | sacchetto PVC con Euro-hole • PVC bags with Euro-hole

L mm	A/B/C	Ø mm	PCS.	COD.	€ cad./each
30	C	44	1	62135005	33,500







*Dettaglio di un'impianto di trasformazione degli idrocarburi.  
Detail of a hydrocarbon transformation system.  
Détail d'une usine de transformation d'hydrocarbures.  
Detalle de una planta de transformación de los hidrocarburos.*

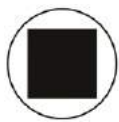

# 3 BUSSOLE E ACCESSORI

SOCKETS AND ACCESSORIES  
DOUILLES ET ACCESSOIRES  
VASOS Y ACCESORIOS

## 64101

### BUSSOLE DENTI ESTERNI PER GHIERE AUTOBLOCCANTI-KMA

40/44 HRC

BUSSOLE PER GHIERE FILETTATE AUTOBLOCCANTI, DENTI ESTERNI  
SOCKETS FOR SELF-LOCKING THREADED NUTS, EXTERNAL TEETH  
DOUILLES POUR BAGUES FILETÉES INDÉSERRABLES, DENTS EXTERNES  
VASOS PARA ABRAZADERAS ROSCADAS DE AUTOBLOQUEO CON DIENTES EXTERNOS

**EASYPACK** | sacchetto PVC con Euro-hole • PVC bags with Euro-hole

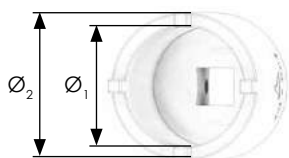

Ø	KMA	Ø <sub>1</sub> mm	Ø <sub>2</sub> mm	PCS.	COD.	€ cad./each
3/8"	0	15,5	20	1	64101005	39,000
3/8"	1	19	24	1	64101010	39,000
1/2"	2	22	27	1	64101015	44,400
1/2"	3	25	30	1	64101020	47,100
1/2"	4	28	36	1	64101025	51,500
1/2"	5	34	42	1	64101030	52,500
1/2"	6	39	48	1	64101035	54,100
1/2"	7	45	54	1	64101040	57,900
1/2"	8	51	61	1	64101045	58,500
3/4"	9	56	67	1	64101050	70,400
3/4"	10	62	73	1	64101055	75,800
3/4"	11	69	82	1	64101060	91,500
3/4"	12	74	87	1	64101065	104,000
3/4"	13	78	92	1	64101070	129,900
3/4"	14	85,5	98	1	64101075	151,600



#### DIMENSIONI GHIERE | lock-nuts dimensions • dimensions des bagues filetées • medidas de las abrazaderas roscadas

M	KMA	Ø <sub>1</sub> mm	Ø <sub>2</sub> mm	
M10x0,75	0	14	18	4
M12x1	1	18	22	4
M15x1	2	21	25	4
M17x1	3	24	28	4
M20x1	4	27	32	4
M25x1,5	5	33	38	4
M30x1,5	6	38	44	4
M35x1,5	7	44	50	4
M40x1,5	8	50	56	4
M45x1,5	9	55	62	4
M50x1,5	10	61	68	4
M55x2	11	68	75	6
M60x2	12	73	80	6
M65x2	13	77	85	6
M70x2	14	84	92	6

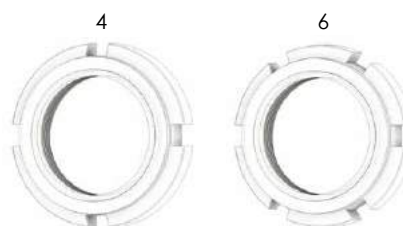
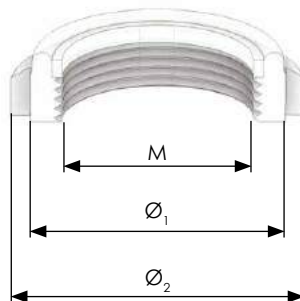

#### FOCUS ON



Le ghiera filettate autobloccanti (KMA - GUK - GUP) si riconoscono dalla presenza di un anello interno di nylon che, al momento dell'avvitamento, crea un effetto bloccante tra vite e madre-vite.

The self-locking threaded ring nuts (KMA - GUK - GUP) are recognised by the presence of an inner nylon ring that, at the time of screwing, creates a blocking effect between the screw and mother-screw.

Les bagues filetées indéserrables (KMA - GUK - GUP) se reconnaissent par la présence d'un anneau intérieur en nylon qui, au moment du vissage, crée un effet de blocage entre la vis et la vis-mère.

Las abrazaderas roscadas de bloqueo automático (KMA - GUK - GUP) se reconocen por la presencia de un anillo interno de nylon que, durante el atornillado, crea un efecto bloqueante entre el tornillo y tornillo madre.

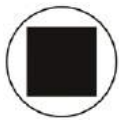
**64102**

# BUSSOLE DENTI INTERNI PER GHIERE AUTOBLOCCANTI-KMA

40/44 HRC

BUSSOLE PER GHIERE FILETTATE AUTOBLOCCANTI, DENTI INTERNI  
SOCKETS FOR SELF-LOCKING THREADED NUTS, INTERNAL TEETH  
DOUILLES POUR BAGUES FILETÉES INDÉSERRABLES, DENTS INTERNES  
VASOS PARA ABRAZADERAS ROSCADAS DE AUTOBLOQUEO CON DIENTES INTERNOS

EASYPACK | sacchetto PVC con Euro-hole • PVC bags with Euro-hole

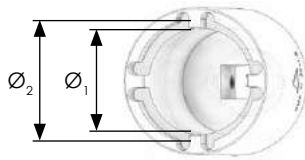

Ø	KMA	Ø <sub>1</sub> mm	Ø <sub>2</sub> mm	PCS.	COD.	€ cad./each
3/8"	0	15,5	18,5	1	64102005	55,800
3/8"	1	19	22,5	1	64102010	55,800
1/2"	2	22	25,5	1	64102015	66,900
1/2"	3	25	29	1	64102020	72,500
1/2"	4	28	33	1	64102025	78,100
1/2"	5	34	39	1	64102030	83,600
1/2"	6	39	46	1	64102035	89,200
1/2"	7	45	53	1	64102040	100,300
1/2"	8	51	59	1	64102045	106,000
3/4"	9	56	66	1	64102050	117,100
3/4"	10	62	71	1	64102055	122,600
3/4"	11	69	76	1	64102060	136,600
3/4"	12	74	81	1	64102065	144,900
3/4"	13	78	86	1	64102070	186,700



## DIMENSIONI BUSSOLE | sockets dimensions • dimensions douilles • medidas vasos

M	KMA	S	H	P	
M10x0,75	0	2,5	5	65	4
M12x1	1	2,5	5	65	4
M15x1	2	3,5	6	65	4
M17x1	3	3,5	6	65	4
M20x1	4	3,5	7	60	4
M25x1,5	5	4,5	7	60	4
M30x1,5	6	4,5	7	60	4
M35x1,5	7	4,5	8	45	4
M40x1,5	8	5,5	9	45	4
M45x1,5	9	5,5	9	35	4
M50x1,5	10	5,5	9	35	4
M55x2	11	6,5	9	35	6
M60x2	12	6,5	9	35	6
M65x2	13	6,5	10	35	6
M70x2	14	7,0	10	35	6

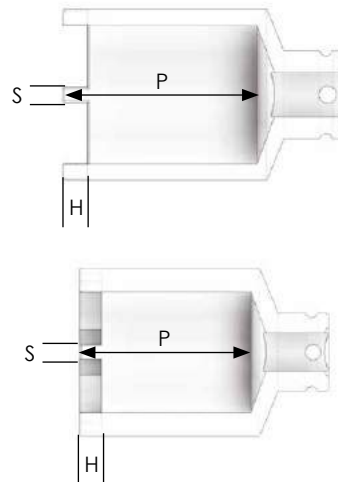

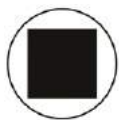

# 3 BUSSOLE E ACCESSORI

SOCKETS AND ACCESSORIES  
DOUILLES ET ACCESSOIRES  
VASOS Y ACCESORIOS

**64109**

## BUSSOLE DENTI ESTERNI PER GHIERE AUTOBLOCCANTI-KMA

BUSSOLE PER GHIERE FILETTATE AUTOBLOCCANTI, DENTI ESTERNI  
SOCKETS FOR SELF-LOCKING THREADED NUTS, EXTERNAL TEETH  
DOUILLES POUR BAGUES FILETÉES INDÉSERRABLES, DENTS EXTERNES  
VASOS PARA ABRAZADERAS ROSCADAS DE AUTOBLOQUEO CON DIENTES EXTERNOS

**EASYPACK** | sacchetto PVC con Euro-hole • PVC bags with Euro-hole

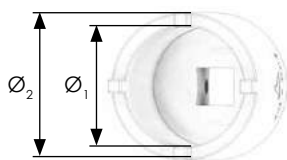

Ø	KMA	Ø <sub>1</sub> mm	Ø <sub>2</sub> mm	PCS.	COD.	€ cad./each
1/2"	<b>2</b>	22	27	1	64109015	<b>27,500</b>
1/2"	<b>3</b>	25	30	1	64109020	<b>29,300</b>
1/2"	<b>4</b>	28	35	1	64109025	<b>32,100</b>
1/2"	<b>7</b>	45	57	1	64109040	<b>34,200</b>
1/2"	<b>8</b>	51	61	1	64109045	<b>35,600</b>
3/4"	<b>9</b>	56	68	1	64109050	<b>38,300</b>
3/4"	<b>10</b>	62	74	1	64109055	<b>41,800</b>
3/4"	<b>11</b>	69	80	1	64109060	<b>54,400</b>
3/4"	<b>12</b>	74	85	1	64109065	<b>63,400</b>
3/4"	<b>13</b>	78	90	1	64109070	<b>73,900</b>



**DIMENSIONI BUSSOLE** | sockets dimensions • dimensions douilles • medidas vasos

M	KMA	S	H	P	
<b>M12x1</b>	<b>1</b>	2,5	3,5	40	4
<b>M15x1</b>	<b>2</b>	3,5	4,0	40	4
<b>M17x1</b>	<b>3</b>	3,5	4,5	40	4
<b>M20x1</b>	<b>4</b>	3,5	5,5	40	4
<b>M25x1,5</b>	<b>5</b>	4,5	6,0	40	4
<b>M30x1,5</b>	<b>6</b>	4,5	6,0	40	4
<b>M35x1,5</b>	<b>7</b>	4,5	6,5	40	4
<b>M40x1,5</b>	<b>8</b>	5,5	7,0	40	4
<b>M45x1,5</b>	<b>9</b>	5,5	8,5	40	4
<b>M50x1,5</b>	<b>10</b>	5,5	9,0	40	4
<b>M55x2</b>	<b>11</b>	6,5	9,0	40	6
<b>M60x2</b>	<b>12</b>	6,5	9,0	40	6
<b>M65x2</b>	<b>13</b>	6,5	9,0	40	6

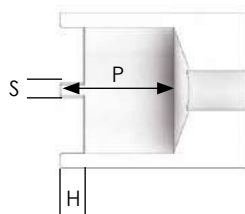

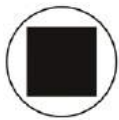

## 64103 ASSORTIMENTI BUSSOLE PER GHIERE AUTOBLOCCANTI-KMA

ASSORTIMENTI 11 PCS. BUSSOLE PER GHIERE AUTOBLOCCANTI  
 KIT WITH 11 SOCKETS FOR SELF-LOCKING NUTS  
 JEUX 11 PIÈCES DOUILLES POUR BAGUES INSÉRRABLES  
 JUEGOS DE 11 PIEZAS DE VASOS PARA ABRAZADERAS DE AUTOBLOQUEO

11  
pcs.



250 X 120 X 180 mm

COD. **64103005**  
€ 626,700



0	1	2	3	4	5	6	7	8	9	10
1pc.	1pc.	1pc.	1pc.	1pc.	1pc.	1pc.	1pc.	1pc.	1pc.	1pc.

COD. **64103010**  
€ 984,200



0	1	2	3	4	5	6	7	8	9	10
1pc.	1pc.	1pc.	1pc.	1pc.	1pc.	1pc.	1pc.	1pc.	1pc.	1pc.

## 64104 ESPOSITORE BUSSOLE PER GHIERE AUTOBLOCCANTI-KMA

ESPOSITORE 11 PCS. BUSSOLE PER GHIERE AUTOBLOCCANTI  
 DISPLAY WITH 11 SOCKETS FOR SELF-LOCKING NUTS  
 PRÉSENTOIR 11 PIÈCES DOUILLES POUR BAGUES INSÉRRABLES  
 JUEGO 11 PIEZAS DE VASOS PARA ABRAZADERAS DE AUTOBLOQUEO

11  
pcs.



240 X 150 X 205 mm

COD. **64104005**  
€ 716,400



0	1	2	3	4	5	6	7	8	9	10
1pc.	1pc.	1pc.	1pc.	1pc.	1pc.	1pc.	1pc.	1pc.	1pc.	1pc.

COD. **64104010**  
€ 1.073,900



0	1	2	3	4	5	6	7	8	9	10
1pc.	1pc.	1pc.	1pc.	1pc.	1pc.	1pc.	1pc.	1pc.	1pc.	1pc.

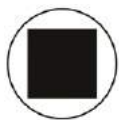

# 3 BUSSOLE E ACCESSORI

SOCKETS AND ACCESSORIES  
DOUILLES ET ACCESSOIRES  
VASOS Y ACCESORIOS

## 64105

### BUSSOLE DENTI ESTERNI PER GHIERE KM

40/44 HRC

BUSSOLE PER GHIERE FILETTATE, DENTI ESTERNI  
SOCKETS FOR THREADED NUTS, EXTERNAL TEETH  
DOUILLES POUR BAGUES FILETÉES, DENTS EXTERNES  
VASOS PARA ABRAZADERAS ROSCADAS CON DIENTES EXTERNOS

EASYPACK | sacchetto PVC con Euro-hole • PVC bags with Euro-hole

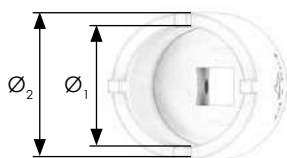

Ø <sub>1</sub> mm	Ø <sub>2</sub> mm	PCS.	COD.	€ cad./each		
3/8"	0	15,5	20	1	64105005	39,000
3/8"	1	19	24	1	64105010	39,000
1/2"	2	22	27	1	64105015	44,400
1/2"	3	25	30	1	64105020	47,100
1/2"	4	29	36	1	64105025	51,500
1/2"	5	35	42	1	64105030	52,500
1/2"	6	42	49	1	64105035	54,100
1/2"	7	49	56	1	64105040	57,900
1/2"	8	54	63	1	64105045	58,500
3/4"	9	61	70	1	64105050	70,400
3/4"	10	66	75	1	64105055	75,800
3/4"	11	70	82	1	64105060	91,500
3/4"	12	75	87	1	64105065	104,000
3/4"	13	80	92	1	64105070	129,900
3/4"	14	86	98	1	64105075	151,600



DIMENSIONI GHIERE | lock-nuts dimensions • dimensions des bagues filetées • medidas de las abrazaderas roscadas

M	KM	Ø <sub>1</sub> mm	Ø <sub>2</sub> mm	
M10x0,75	0	14	18	4
M12x1	1	18	22	4
M15x1	2	21	25	4
M17x1	3	24	28	4
M20x1	4	28	32	4
M25x1,5	5	34	38	4
M30x1,5	6	41	45	4
M35x1,5	7	48	52	4
M40x1,5	8	53	58	4
M45x1,5	9	60	65	4
M50x1,5	10	65	70	4
M55x2	11	69	75	4
M60x2	12	74	80	4
M65x2	13	79	85	4
M70x2	14	86	92	4

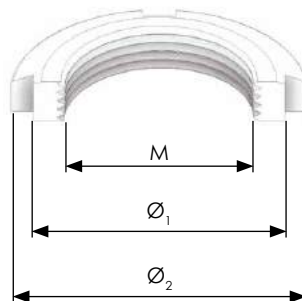

### FOCUS ON



Ghiere filettate (DIN 981 - KM), interamente in acciaio.  
Threaded ring nuts (DIN 981 - KM), entirely in steel.  
Bagues filetées (DIN 981 - Km), entièrement en acier.  
Abrazaderas roscadas (DIN 981 - KM), completamente de acero.

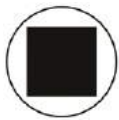

# 64106 BUSSOLE DENTI INTERNI PER GHIERE KM

BUSSOLE PER GHIERE FILETTATE, DENTI INTERNI  
 SOCKETS FOR THREADED NUTS, INTERNAL TEETH  
 DOUILLES POUR BAGUES FILETÉES, DENTS INTERNES  
 VASOS PARA ABRAZADERAS ROSCADAS CON DIENTES INTERNOS

40/44 HRC

**EASYPACK** | sacchetto PVC con Euro-hole • PVC bags with Euro-hole



Ø	KM	Ø <sub>1</sub> mm	Ø <sub>2</sub> mm	PCS.	COD.	€ cad./each
3/8"	0	15,5	18,5	1	64106005	55,800
3/8"	1	19	22,5	1	64106010	55,800
1/2"	2	22	25,5	1	64106015	66,900
1/2"	3	25	29	1	64106020	72,500
1/2"	4	29	33	1	64106025	78,100
1/2"	5	35	39	1	64106030	83,600
1/2"	6	42	46	1	64106035	89,200
1/2"	7	49	53	1	64106040	100,300
1/2"	8	54	59	1	64106045	106,000
3/4"	9	61	66	1	64106050	117,100
3/4"	10	66	71	1	64106055	122,600
3/4"	11	70	76	1	64106060	136,600
3/4"	12	75	81	1	64106065	144,900
3/4"	13	80	86	1	64106070	186,700



**DIMENSIONI BUSSOLE** | sockets dimensions • dimensions douilles • medidas vasos

M	KM	S	H	P	
M10x0,75	0	2,5	5	65	4
M12x1	1	2,5	5	65	4
M15x1	2	3,5	6	65	4
M17x1	3	3,5	6	65	4
M20x1	4	3,5	7	60	4
M25x1,5	5	4,5	8	60	4
M30x1,5	6	4,5	8	60	4
M35x1,5	7	4,5	9	45	4
M40x1,5	8	5,5	10	45	4
M45x1,5	9	5,5	11	35	4
M50x1,5	10	5,5	12	35	4
M55x2	11	6,5	12	35	4
M60x2	12	6,5	12	35	4
M65x2	13	6,5	13	35	4
M70x2	14	7,0	13	35	4

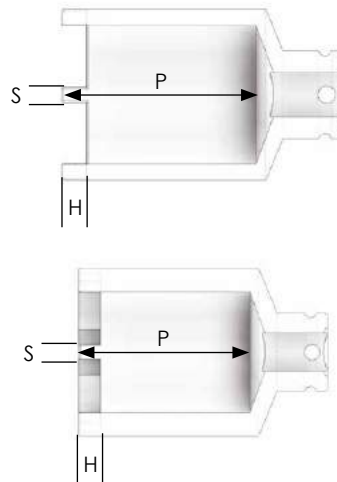

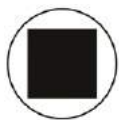

# 3 BUSSOLE E ACCESSORI

SOCKETS AND ACCESSORIES  
DOUILLES ET ACCESSOIRES  
VASOS Y ACCESORIOS

**64110**

## BUSSOLE DENTI ESTERNI PER GHIERE KM

BUSSOLE PER GHIERE FILETTATE, DENTI ESTERNI  
SOCKETS FOR THREADED NUTS, EXTERNAL TEETH  
DOUILLES POUR BAGUES FILETÉES, DENTS EXTERNES  
VASOS PARA ABRAZADERAS ROSCADAS CON DIENTES EXTERNOS

**EASYPACK** | sacchetto PVC con Euro-hole • PVC bags with Euro-hole

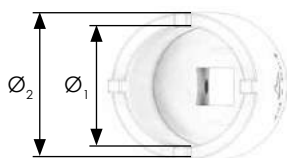

Ø	KM	Ø <sub>1</sub> mm	Ø <sub>2</sub> mm	PCS.	COD.	€ cad./each
1/2"	6	42	51	1	64110035	33,500
1/2"	7	49	58	1	64110040	34,200
1/2"	8	54	63	1	64110045	35,600
3/4"	9	61	72	1	64110050	38,300
3/4"	10	66	77	1	64110055	41,800
3/4"	11	70	82	1	64110060	54,400
3/4"	12	75	87	1	64110065	63,400
3/4"	13	80	92	1	64110070	73,900



**DIMENSIONI BUSSOLE** | sockets dimensions • dimensions douilles • medidas vasos

M	KM	S	H	P	
M12x1	1	2,5	5,0	40	4
M15x1	2	3,5	6,0	40	4
M17x1	3	3,5	6,0	40	4
M20x1	4	3,5	7,0	40	4
M25x1,5	5	4,5	8,0	40	4
M30x1,5	6	4,5	8,0	40	4
M35x1,5	7	4,5	9,0	40	4
M40x1,5	8	5,5	10,0	40	4
M45x1,5	9	5,5	11,0	40	4
M50x1,5	10	5,5	12,0	40	4
M55x2	11	6,5	8,0	40	4
M60x2	12	6,5	9,0	40	4
M65x2	13	6,5	10,0	40	4

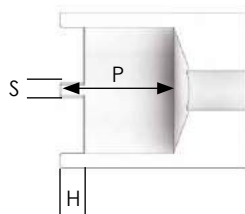



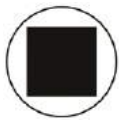

# 64107 ASSORTIMENTI BUSSOLE PER GHIERE KM

ASSORTIMENTI 11 PCS. BUSSOLE PER GHIERE  
 KIT WITH 11 SOCKETS FOR NUTS  
 JEUX 11 PIÈCES DOUILLES POUR BAGUES  
 JUEGOS DE 11 PIEZAS DE VASOS PARA ABRAZADERAS

11 pcs.



250 X 120 X 180 mm

COD. **64107005**  
 € 626,700

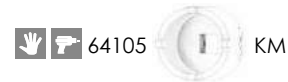

0	1	2	3	4	5	6	7	8	9	10
1pc.	1pc.	1pc.	1pc.	1pc.	1pc.	1pc.	1pc.	1pc.	1pc.	1pc.

COD. **64107010**  
 € 984,200



0	1	2	3	4	5	6	7	8	9	10
1pc.	1pc.	1pc.	1pc.	1pc.	1pc.	1pc.	1pc.	1pc.	1pc.	1pc.

# 64108 ESPOSITORE BUSSOLE PER GHIERE KM

ESPOSITORE 11 PCS. BUSSOLE PER GHIERE  
 DISPLAY WITH 11 SOCKETS FOR NUTS  
 PRÉSENTOIR 11 PIÈCES DOUILLES POUR BAGUES  
 JUEGO 11 PIEZAS DE VASOS PARA ABRAZADERAS

11 pcs.



240 X 150 X 205 mm

COD. **64108005**  
 € 716,400

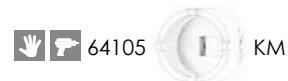

0	1	2	3	4	5	6	7	8	9	10
1pc.	1pc.	1pc.	1pc.	1pc.	1pc.	1pc.	1pc.	1pc.	1pc.	1pc.

COD. **64108010**  
 € 1.073,900



0	1	2	3	4	5	6	7	8	9	10
1pc.	1pc.	1pc.	1pc.	1pc.	1pc.	1pc.	1pc.	1pc.	1pc.	1pc.





# 3 BUSSOLE E ACCESSORI

SOCKETS AND ACCESSORIES  
DOUILLES ET ACCESSOIRES  
VASOS Y ACCESORIOS

**64061**

**IMPACT 3/4"**

BUSSOLE IMPACT 3/4" CAVA ESAGONALE  
3/4" HEXAGONAL RECESS IMPACT SOCKETS  
DOUILLES IMPACT 3/4" HEXAGONALES CREUSES  
VASOS IMPACT DE 3/4" CON CAVIDAD HEXAGONAL

40/44 HRC

**EASYPACK** | sacchetto PVC con Euro-hole • PVC bags with Euro-hole

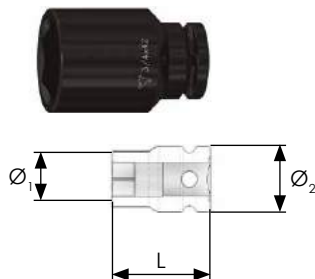

●	L mm	Ø <sub>1</sub> mm	Ø <sub>2</sub> mm	PCS.	COD.	€ cad./each
13	45	25	44	1	64061010	25,400
14	45	25	44	1	64061015	25,400
15	45	29	44	1	64061025	25,400
16	45	29	44	1	64061035	25,400
17	45	29	44	1	64061040	25,400
18	45	32	44	1	64061050	25,400
19	45	32	44	1	64061055	26,000
20	45	35	44	1	64061060	27,600
21	45	35	44	1	64061070	27,600
22	45	38	44	1	64061075	27,600
23	45	38	44	1	64061085	27,600
24	45	41	44	1	64061095	27,600
25	45	41	44	1	64061100	29,100
26	45	41	44	1	64061110	29,100
27	50	41	44	1	64061115	29,900
28	50	44	44	1	64061120	29,900
29	50	44	44	1	64061130	29,900
30	50	44	44	1	64061135	29,900
31	50	49	44	1	64061140	32,900
32	50	49	44	1	64061150	32,900
33	55	49	44	1	64061155	39,400
34	55	52	44	1	64061165	40,600
35	55	52	44	1	64061170	40,600
36	55	52	44	1	64061175	40,600
37	55	54	44	1	64061185	42,400
38	60	54	44	1	64061190	42,400
39	60	57	44	1	64061195	47,700
40	60	57	44	1	64061205	49,100
41	60	57	44	1	64061210	49,100
42	60	60	44	1	64061215	51,700
43	65	63	44	1	64061220	51,700
44	65	63	44	1	64061225	56,000
45	65	63	44	1	64061235	63,300
46	65	67	44	1	64061240	59,500
47	70	67	54	1	64061245	63,300
48	70	67	54	1	64061255	72,200
49	70	70	54	1	64061260	72,200
50	70	70	54	1	64061265	72,200
51	70	73	54	1	64061270	76,800
52	70	73	54	1	64061275	76,800
54	70	73	54	1	64061285	89,000
55	70	78	54	1	64061290	88,100
56	75	78	54	1	64061300	94,900
57	75	82	54	1	64061305	95,400
58	75	82	54	1	64061310	97,200
59	75	82	54	1	64061315	97,200
60	75	82	54	1	64061320	100,200
61	75	86	54	1	64061330	113,900





# 64063 IMPACT 3/4" SERIE LUNGA

BUSSOLE IMPACT 3/4" CAVA ESAGONALE - TIPO LUNGO  
3/4" HEXAGONAL RECESS IMPACT SOCKETS - LONG SERIES  
DOUILLES IMPACT 3/4" HEXAGONALES - CREUSES LONGUES  
VASOS IMPACT DE 3/4" CON CAVIDAD HEXAGONAL - TIPO LARGO

40/44 HRC

EASYPACK | sacchetto PVC con Euro-hole • PVC bags with Euro-hole

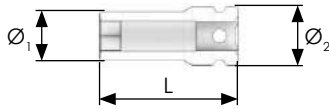

●	L mm	Ø <sub>1</sub> mm	Ø <sub>2</sub> mm	PCS.	COD.	€ cad./each
13	90	25	44	1	64063010	42,700
14	90	25	44	1	64063015	42,700
15	90	29	44	1	64063025	42,700
16	90	29	44	1	64063035	43,500
17	90	29	44	1	64063040	43,500
18	90	32	44	1	64063050	43,500
19	90	32	44	1	64063055	43,500
20	90	35	44	1	64063060	43,500
21	90	35	44	1	64063070	43,500
22	90	38	44	1	64063075	43,500
23	90	38	44	1	64063085	44,400
24	90	41	44	1	64063095	44,400
25	90	41	44	1	64063100	44,400
26	90	41	44	1	64063110	44,400
27	90	41	44	1	64063115	44,400
28	90	44	44	1	64063120	52,100
29	90	44	44	1	64063130	52,100
30	90	44	44	1	64063135	52,100
31	90	49	44	1	64063140	53,700
32	90	49	44	1	64063150	53,700
33	90	49	44	1	64063155	68,900
34	90	52	44	1	64063165	68,900
35	90	52	44	1	64063170	68,900
36	90	52	44	1	64063175	68,900
37	90	54	44	1	64063185	73,900
38	90	54	44	1	64063190	73,900
39	90	57	44	1	64063195	78,900
40	90	57	44	1	64063205	78,900
41	90	57	44	1	64063210	81,500
42	90	60	44	1	64063215	81,500
43	90	63	44	1	64063220	81,500
44	90	63	44	1	64063225	102,000
45	90	63	44	1	64063235	102,000
46	90	67	44	1	64063240	102,000
47	90	67	54	1	64063245	102,000
48	90	67	54	1	64063255	116,400
49	90	70	54	1	64063260	116,400
50	90	70	54	1	64063265	116,400
51	90	73	54	1	64063270	116,400
52	95	73	54	1	64063275	121,400
54	95	73	54	1	64063285	143,500
55	95	78	54	1	64063290	149,500
56	100	78	54	1	64063300	153,000
57	100	82	54	1	64063305	153,800
58	100	82	54	1	64063310	156,600
59	100	82	54	1	64063315	156,600
60	100	82	54	1	64063320	169,600
61	100	86	54	1	64063330	213,600





# 3 BUSSOLE E ACCESSORI

SOCKETS AND ACCESSORIES  
DOUILLES ET ACCESSOIRES  
VASOS Y ACCESORIOS

**64139**

## IMPACT 3/4" INTEGRALE ESAGONO MASCHIO

40/44 HRC

BUSSOLE IMPACT 3/4" ESAGONO MASCHIO INTEGRALI  
3/4" IMPACT SOCKETS INTEGRAL MALE HEXAGON  
DOUILLES IMPACT 3/4" HEXAGONALES MÂLES INTÉGRALES  
VASOS IMPACT DE 3/4" HEXAGONALES MACHO INTEGRAL

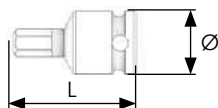

**EASYPACK** | sacchetto PVC con Euro-hole • PVC bags with Euro-hole

Ø	L mm	Ø mm	PCS.	COD.	€ cad./each
10	60	38	1	64139005	20,400
11	60	38	1	64139010	20,400
12	60	38	1	64139015	20,400
13	60	38	1	64139020	22,400
14	60	38	1	64139025	22,400
15	60	38	1	64139030	22,400
16	60	38	1	64139035	22,400
17	60	38	1	64139040	22,400
18	60	38	1	64139045	22,400
19	65	44	1	64139050	22,400
20	65	44	1	64139055	26,800
21	65	44	1	64139060	26,800
22	65	44	1	64139065	26,800
23	65	44	1	64139070	26,800
24	65	44	1	64139075	26,800



**62205**

## PROLUNGHE

40/44 HRC

PROLUNGA PER BUSSOLE 3/4"  
EXTENSION FOR 3/4" SOCKETS  
RALLONGE POUR DOUILLES 3/4"  
EXTENSION PARA VASOS DE 3/4"

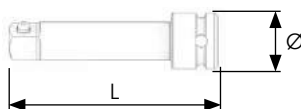
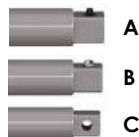

**EASYPACK** | sacchetto PVC con Euro-hole • PVC bags with Euro-hole

L mm	A/B/C	Ø mm	PCS.	COD.	€ cad./each
75	C	44	1	62205005	62,400
100	C	44	1	62205010	66,300
125	C	44	1	62205015	70,700
175	C	44	1	62205020	61,600
250	C	44	1	62205025	68,300
325	C	44	1	62205030	103,800





## 62207 PROLUNGHE SNODATE

PROLUNGA PER BUSSOLE 3/4" SNODATA  
UNIVERSAL JOINT FOR 3/4" SOCKETS  
RALLONGE POUR DOUILLES 3/4" ARTICULÉ  
EXTENSIÓN PARA VASOS DE 3/4" CON ARTICULACIÓN

40/44 HRC

**EASYPACK** | sacchetto PVC con Euro-hole • PVC bags with Euro-hole



L mm	A/B/C	Ø mm	PCS.	COD.	€ cad./each
95	C	44	1	62207005	93,500

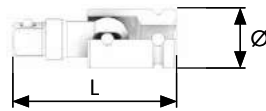
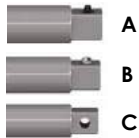

## 62206 PROLUNGHE SGANCIO RAPIDO

PROLUNGA PER BUSSOLE 3/4" SNODATA CON BLOCCO  
UNIVERSAL JOINT FOR 3/4" SOCKETS WITH LOCK  
RALLONGE POUR DOUILLES 3/4" ARTICULÉE AVEC BLOPAGE  
EXTENSIÓN PARA VASOS DE 3/4" CON ARTICULACIÓN Y BLOQUEO

40/44 HRC

**EASYPACK** | sacchetto PVC con Euro-hole • PVC bags with Euro-hole



L mm	A/B/C	Ø mm	PCS.	COD.	€ cad./each
80	B	44	1	62206005	183,500

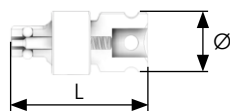
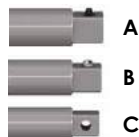



# 3 BUSSOLE E ACCESSORI

SOCKETS AND ACCESSORIES  
DOUILLES ET ACCESSOIRES  
VASOS Y ACCESORIOS

## 62126 RIDUZIONI PER BUSSOLE 1/2"

RIDUZIONE 3/4" PER BUSSOLE DA 1/2"  
3/4" REDUCTION FOR 1/2" SOCKETS  
RÉDUCTION 3/4" POUR DOUILLES DE 1/2"  
REDUCTOR DE 3/4" PARA VASOS DE 1/2"

40/44 HRC

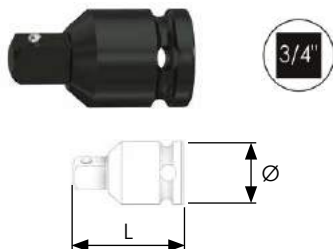
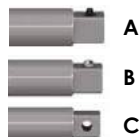

**EASYPACK** | sacchetto PVC con Euro-hole • PVC bags with Euro-hole

L mm	A/B/C	Ø mm	PCS.	COD.	€ cad./each
55	C	44	1	62126005	35,400
55	B	44	1	62126010	48,300
175	B	44	1	62126015	61,600



## 62141 ADATTATORI PER BUSSOLE 1"

ADATTATORE/AUMENTATORE 3/4" PER BUSSOLE DA 1"  
3/4" ADAPTER/ENHANCER FOR 1" SOCKETS  
ADAPTATEUR/AUGMENTATEUR 3/4" POUR DOUILLES DE 1"  
ADAPTADOR/EXTENSOR DE 3/4" PARA VASOS DE 1"

40/44 HRC

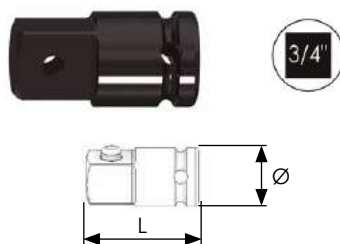
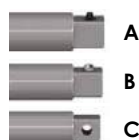

**EASYPACK** | sacchetto PVC con Euro-hole • PVC bags with Euro-hole

L mm	A/B/C	Ø mm	PCS.	COD.	€ cad./each
60	C	44	1	62141005	50,900



## 62126 RIDUZIONI PER BUSSOLE 1/2"

RIDUZIONE 3/4" PER BUSSOLE DA 1/2"  
3/4" REDUCTION FOR 1/2" SOCKETS  
RÉDUCTION 3/4" POUR DOUILLES DE 1/2"  
REDUCTOR DE 3/4" PARA VASOS DE 1/2"

**EASYPACK** | sacchetto PVC con Euro-hole • PVC bags with Euro-hole

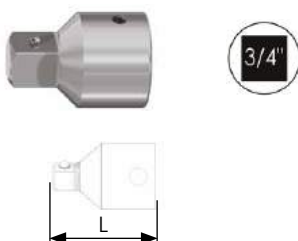
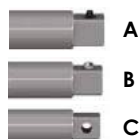

L mm	A/B/C	Ø mm	PCS.	COD.	€ cad./each
50	B	32	1	62126001	7,640



**SELPACK**  
1 pc.

L mm	COD.	€ box
50	62126001001	8,980

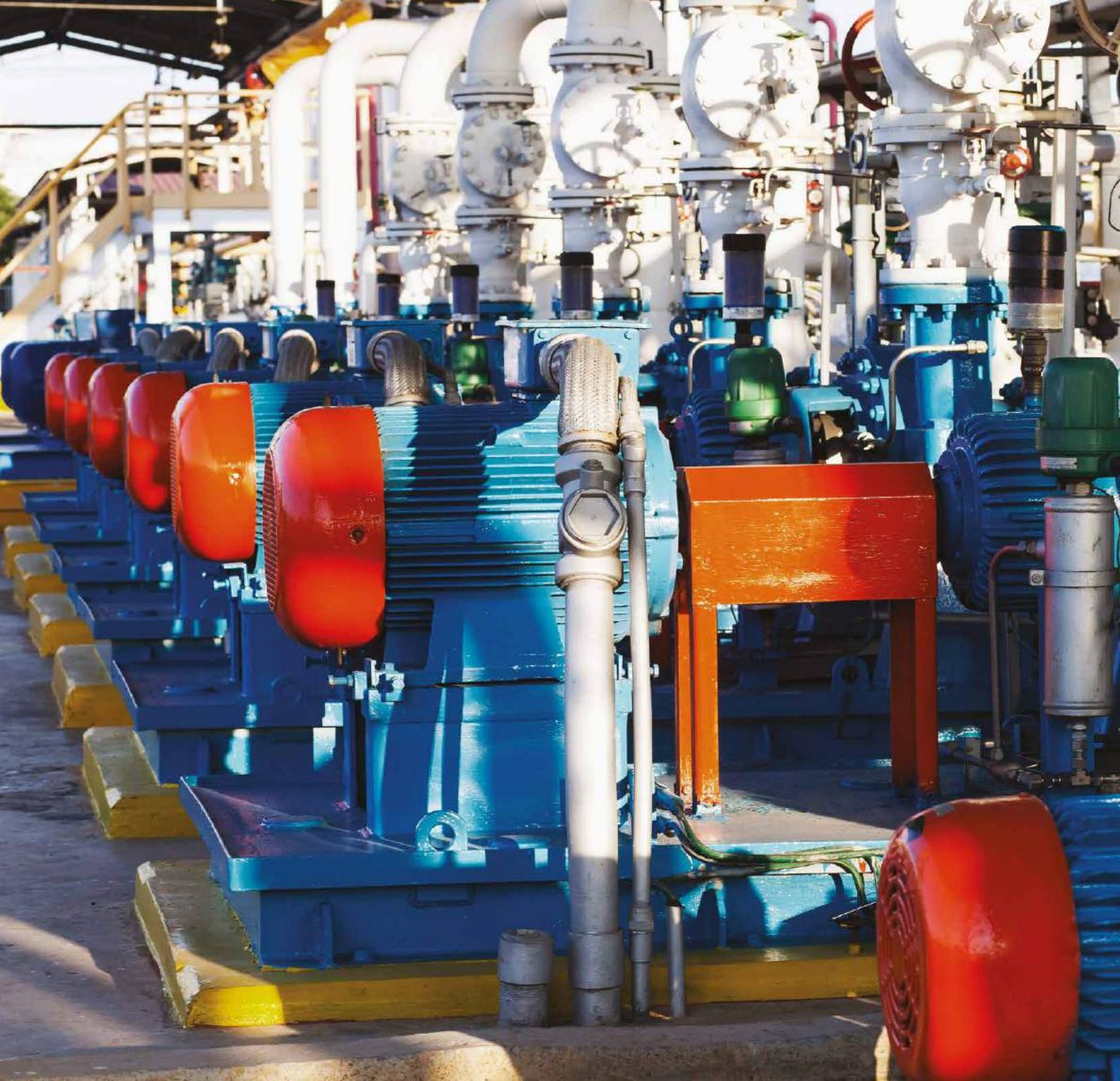

*Vista di impianti di pompe industriali.*

*An industrial pump.*

*Vue des systèmes de pompes industrielles.*

*Vista de plantas de bombas industriales.*



# 3 BUSSOLE E ACCESSORI

SOCKETS AND ACCESSORIES  
DOUILLES ET ACCESSOIRES  
VASOS Y ACCESORIOS

**64071**

**IMPACT 1"**

BUSSOLE IMPACT 1" CAVA ESAGONALE  
1" HEXAGONAL RECESS IMPACT SOCKETS  
DOUILLES IMPACT 1" HEXAGONALES CREUSES  
VASOS IMPACT DE 1" CON CAVIDAD HEXAGONAL

40/44 HRC

**EASYPACK** | sacchetto PVC con Euro-hole • PVC bags with Euro-hole

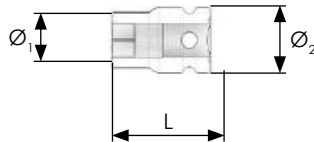

Icon	L mm	Ø <sub>1</sub> mm	Ø <sub>2</sub> mm	PCS.	COD.	€ cad./each	
	19	55	36	54	1	64071005	43,000
	20	55	37	54	1	64071010	43,000
	21	55	38	54	1	64071015	43,000
	22	55	40	54	1	64071020	43,000
	23	55	41	54	1	64071025	43,000
	24	55	42	54	1	64071030	44,900
	25	55	43	54	1	64071035	44,900
	26	55	45	54	1	64071040	44,900
	27	55	46	54	1	64071045	44,900
	28	55	47	54	1	64071050	44,900
	29	60	48	54	1	64071055	44,900
	30	60	50	54	1	64071060	44,900
	31	60	51	54	1	64071065	44,900
	32	60	51	54	1	64071070	44,900
	33	60	54	54	1	64071075	44,900
	34	60	54	54	1	64071080	49,900
	35	60	54	54	1	64071085	49,900
	36	60	54	54	1	64071090	49,900
	37	60	54	54	1	64071095	49,900
	38	65	60	54	1	64071100	49,900
	39	65	60	54	1	64071105	49,900
	40	65	63	54	1	64071110	59,100
	41	65	63	54	1	64071115	59,100
	42	65	63	54	1	64071120	59,100
	43	70	67	54	1	64071125	64,300
	44	70	67	54	1	64071130	64,300
	45	70	70	54	1	64071135	67,700
	46	70	70	54	1	64071140	67,700
	47	70	70	54	1	64071145	70,100
	48	70	73	54	1	64071150	72,100

Icon	L mm	Ø <sub>1</sub> mm	Ø <sub>2</sub> mm	PCS.	COD.	€ cad./each	
	49	70	73	54	1	64071155	77,600
	50	70	73	54	1	64071160	82,300
	51	70	73	54	1	64071165	83,100
	52	70	78	54	1	64071170	88,100
	54	80	82	54	1	64071175	88,100
	55	80	82	54	1	64071180	92,500
	56	80	82	54	1	64071185	101,300
	57	80	82	54	1	64071190	108,500
	58	80	86	54	1	64071195	109,300
	59	80	86	54	1	64071200	109,300
	60	80	86	54	1	64071205	114,600
	61	85	88	54	1	64071210	130,800
	62	85	92	54	1	64071215	125,600
	65	85	92	54	1	64071220	125,600
	67	90	92	54	1	64071225	132,200
	70	90	96	86	1	64071230	132,200
	73	90	100	86	1	64071235	174,000
	75	90	100	86	1	64071240	174,000
	76	100	105	86	1	64071245	222,500
	77	100	105	86	1	64071250	222,500
	80	100	105	86	1	64071255	222,500
	85	100	115	86	1	64071260	286,300
	86	105	115	86	1	64071265	329,400
	90	105	127	86	1	64071270	337,100
	95	105	135	86	1	64071275	387,400
	100	110	135	86	1	64071280	427,200
	105	110	145	127	1	64071285	472,100
	110	120	150	127	1	64071290	554,300
	115	120	155	127	1	64071295	637,000



p. 318





# 64072 IMPACT 1" SERIE LUNGA

BUSSOLE IMPACT 1" CAVA ESAGONALE - TIPO LUNGO  
 1" HEXAGONAL RECESS IMPACT SOCKETS - LONG SERIES  
 DOUILLES IMPACT 1" HEXAGONALES - CREUSES LONGUES  
 VASOS IMPACT DE 1" CON CAVIDAD HEXAGONAL - TIPO LARGO

40/44 HRC

EASYPACK | sacchetto PVC con Euro-hole • PVC bags with Euro-hole

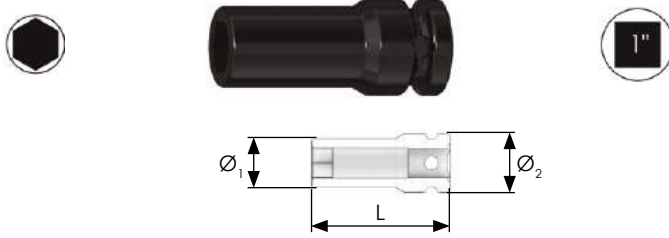

●	L mm	Ø <sub>1</sub> mm	Ø <sub>2</sub> mm	PCS.	COD.	€ cad./each
19	100	36	54	1	64072005	66,300
20	100	37	54	1	64072010	66,300
21	100	38	54	1	64072015	66,300
22	100	40	54	1	64072020	66,300
23	100	41	54	1	64072025	66,300
24	100	42	54	1	64072030	66,300
25	100	43	54	1	64072035	66,300
26	100	45	54	1	64072040	66,300
27	100	46	54	1	64072045	69,800
28	100	47	54	1	64072050	69,800
29	100	48	54	1	64072055	69,800
30	100	50	54	1	64072060	70,200
31	100	51	54	1	64072065	70,200
32	100	51	54	1	64072070	70,200
33	100	54	54	1	64072075	73,500
34	100	54	54	1	64072080	76,500
35	100	54	54	1	64072085	76,500
36	100	54	54	1	64072090	76,500
37	100	54	54	1	64072095	86,000
38	100	60	54	1	64072100	86,000
39	100	60	54	1	64072105	91,800
40	100	63	54	1	64072110	91,800
41	100	63	54	1	64072115	91,800
42	100	63	54	1	64072120	93,500
43	100	67	54	1	64072125	93,500
44	100	67	54	1	64072130	102,000
45	100	70	54	1	64072135	108,000
46	100	70	54	1	64072140	108,000
47	100	70	54	1	64072145	132,500
48	100	73	54	1	64072150	132,500

●	L mm	Ø <sub>1</sub> mm	Ø <sub>2</sub> mm	PCS.	COD.	€ cad./each
49	100	73	54	1	64072155	132,500
50	100	73	54	1	64072160	132,500
51	100	73	54	1	64072165	132,500
52	100	78	54	1	64072170	132,500
54	105	82	54	1	64072175	149,700
55	105	82	54	1	64072180	159,000
56	105	82	54	1	64072185	172,200
57	105	82	54	1	64072190	172,200
58	105	86	54	1	64072195	178,800
59	105	86	54	1	64072200	178,800
60	105	86	54	1	64072205	178,800
61	120	88	54	1	64072210	220,700
62	120	92	54	1	64072215	266,000
65	120	92	54	1	64072220	266,000
67	120	92	54	1	64072225	291,400
70	125	96	86	1	64072230	291,400
73	125	100	86	1	64072235	405,800
75	125	100	86	1	64072240	428,500
76	130	105	86	1	64072245	428,500
77	130	105	86	1	64072250	428,500
80	130	105	86	1	64072255	482,100
85	130	115	86	1	64072260	519,600
86	140	115	86	1	64072265	562,400
90	140	127	86	1	64072270	669,500
95	140	135	86	1	64072275	771,300
100	140	135	86	1	64072280	850,300
105	140	145	127	1	64072285	934,700
110	150	150	127	1	64072290	1.097,200
115	150	155	127	1	64072295	1.261,100





# 3 BUSSOLE E ACCESSORI

SOCKETS AND ACCESSORIES  
DOUILLES ET ACCESSOIRES  
VASOS Y ACCESORIOS

**62211**

## PROLUNGHE

PROLUNGA PER BUSSOLE 1"  
EXTENSION FOR 1" SOCKETS  
RALLONGE POUR DOUILLES 1"  
EXTENSION PARA VASOS DE 1"

40/44 HRC

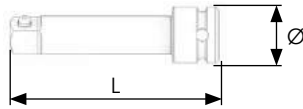
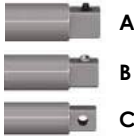

**EASYPACK** | sacchetto PVC con Euro-hole • PVC bags with Euro-hole

L mm	A/B/C	Ø mm	PCS.	COD.	€ cad./each
100	C	54	1	62211005	104,200
125	C	54	1	62211010	110,500
175	C	54	1	62211015	125,900
250	C	54	1	62211020	150,000
330	C	54	1	62211025	176,800



**62212**

## PROLUNGHE SNODATE

PROLUNGA PER BUSSOLE 1" SNODATA  
UNIVERSAL JOINT FOR 1" SOCKETS  
RALLONGE POUR DOUILLES 1" ARTICULÉE  
EXTENSION PARA VASOS DE 1" CON ARTICULACIÓN

40/44 HRC

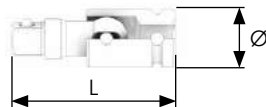
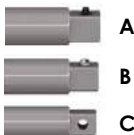

**EASYPACK** | sacchetto PVC con Euro-hole • PVC bags with Euro-hole

L mm	A/B/C	Ø mm	PCS.	COD.	€ cad./each
135	C	54	1	62212005	199,300





# 62137 RIDUZIONI PER BUSSOLE 3/4"

RIDUZIONE 1" PER BUSSOLE DA 3/4"  
1" REDUCTION FOR 3/4" SOCKETS  
RÉDUCTION 1" POUR DOUILLES DE 3/4"  
REDUCTOR DE 1" PARA VASOS DE 3/4"

40/44 HRC

EASYPACK | sacchetto PVC con Euro-hole • PVC bags with Euro-hole



L mm	A/B/C	Ø mm	PCS.	COD.	€ cad./each
77	C	54	1	62137005	78,600

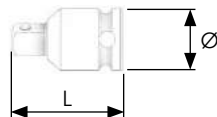
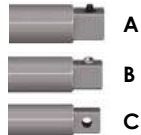

# 62145 ADATTATORI PER BUSSOLE 1-1/2"

ADATTATORE/AUMENTATORE 1" PER BUSSOLE DA 1-1/2"  
1" ADAPTER/ENHANCER FOR 1-1/2" SOCKETS  
ADAPTATEUR/AUGMENTATEUR 1" POUR DOUILLES DE 1-1/2"  
ADAPTADOR/EXTENSOR DE 1" PARA VASOS DE 1-1/2"

40/44 HRC

EASYPACK | sacchetto PVC con Euro-hole • PVC bags with Euro-hole



L mm	A/B/C	Ø mm	PCS.	COD.	€ cad./each
85	C	54	1	62145005	136,600

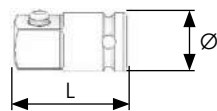
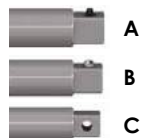



# 3 BUSSOLE E ACCESSORI

SOCKETS AND ACCESSORIES  
DOUILLES ET ACCESSOIRES  
VASOS Y ACCESORIOS

**64081**

**IMPACT 1-1/2"**

BUSSOLE IMPACT 1-1/2" CAVA ESAGONALE  
1-1/2" HEXAGONAL RECESS IMPACT SOCKETS  
DOUILLES IMPACT 1-1/2" HEXAGONALES CREUSES  
VASOS IMPACT DE 1-1/2" CON CAVIDAD HEXAGONAL

40/44 HRC

**EASYPACK** | sacchetto PVC con Euro-hole • PVC bags with Euro-hole



●	L mm	Ø <sub>1</sub> mm	Ø <sub>2</sub> mm	PCS.	COD.	€ cad./each
32	75	60	86	1	64081005	137,400
33	75	60	86	1	64081010	137,400
34	75	60	86	1	64081015	137,400
35	75	60	86	1	64081020	137,400
36	80	64	86	1	64081025	147,700
37	80	64	86	1	64081030	147,700
38	80	64	86	1	64081035	147,700
39	80	70	86	1	64081040	147,700
40	80	70	86	1	64081045	147,700
41	80	70	86	1	64081050	147,700
42	80	70	86	1	64081055	147,700
43	80	75	86	1	64081060	147,700
44	80	75	86	1	64081065	147,700
45	80	75	86	1	64081070	147,700
46	80	75	86	1	64081075	147,700
47	80	75	86	1	64081080	147,700
48	80	80	86	1	64081085	150,800
49	80	80	86	1	64081090	150,800
50	80	80	86	1	64081095	150,800
51	80	80	86	1	64081100	150,800
52	90	80	86	1	64081105	150,800
54	90	86	86	1	64081110	150,800
55	90	86	86	1	64081115	150,800
56	90	86	86	1	64081120	168,300
57	90	86	86	1	64081125	168,300
58	90	92	86	1	64081130	168,300
59	90	92	86	1	64081135	168,300
60	90	92	86	1	64081140	185,400
61	95	96	86	1	64081145	185,400
62	95	96	86	1	64081150	185,400
65	95	100	86	1	64081155	206,600
67	100	100	86	1	64081160	214,600
70	100	105	86	1	64081165	278,100
73	105	109	86	1	64081170	324,700
75	105	109	86	1	64081175	336,500
76	110	115	86	1	64081180	359,500
77	110	115	86	1	64081185	394,200
80	110	115	86	1	64081190	394,200
85	115	121	86	1	64081195	417,200
86	115	127	86	1	64081200	440,800
90	120	130	86	1	64081205	455,000
95	120	135	127	1	64081210	695,300
100	125	140	127	1	64081215	778,700
105	125	150	127	1	64081220	883,000
110	135	155	127	1	64081225	959,400
115	135	160	127	1	64081230	959,400
120	145	165	127	1	64081235	1.056,800
125	145	170	127	1	64081240	1.068,200
130	160	180	127	1	64081245	1.125,600





## 62215 PROLUNGHE

PROLUNGA PER BUSSOLE 1-1/2"  
EXTENSION FOR 1-1/2" SOCKETS  
RALLONGE POUR DOUILLES 1-1/2"  
EXTENSION PARA VASOS DE 1-1/2"

40/44 HRC

**EASYPACK** | sacchetto PVC con Euro-hole • PVC bags with Euro-hole

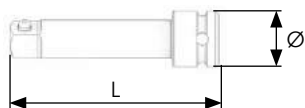
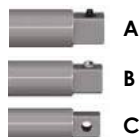

L mm	A/B/C	Ø mm	PCS.	COD.	€ cad./each
150	C	86	1	62215005	448,600
225	C	86	1	62215010	515,600
300	C	86	1	62215015	573,100
500	C	54	1	62215020	649,500



## 62216 PROLUNGHE SNODATE

PROLUNGA PER BUSSOLE 1-1/2" SNODATA  
UNIVERSAL JOINT FOR 1-1/2" SOCKETS  
RALLONGE POUR DOUILLES 1-1/2" ARTICULÉE  
EXTENSION PARA VASOS DE 1-1/2" CON ARTICULACIÓN

40/44 HRC

**EASYPACK** | sacchetto PVC con Euro-hole • PVC bags with Euro-hole

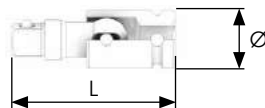
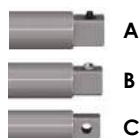

L mm	A/B/C	Ø mm	PCS.	COD.	€ cad./each
125	C	86	1	62216005	618,700



## 62142 RIDUZIONI PER BUSSOLE 1"

RIDUZIONE 1-1/2" PER BUSSOLE DA 1"  
1-1/2" REDUCTION FOR 1" SOCKETS  
RÉDUCTION 1-1/2" POUR DOUILLES DE 1"  
REDUCTOR DE 1-1/2" PARA VASOS DE 1"

40/44 HRC

**EASYPACK** | sacchetto PVC con Euro-hole • PVC bags with Euro-hole

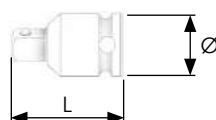
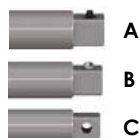

L mm	A/B/C	Ø mm	PCS.	COD.	€ cad./each
95	C	86	1	62142005	251,800





# 3 BUSSOLE E ACCESSORI

SOCKETS AND ACCESSORIES  
DOUILLES ET ACCESSOIRES  
VASOS Y ACCESORIOS

## 64999 O-RING ANELLO FERMO

ANELLO FERMO PER SPINA DI BLOCCAGGIO  
IMPACT SOCKET RETAINING RING  
JOINTS O-RING POUR DOUILLES IMPACT  
ANILLO DE RETENCION PARA VASOS IMPACT

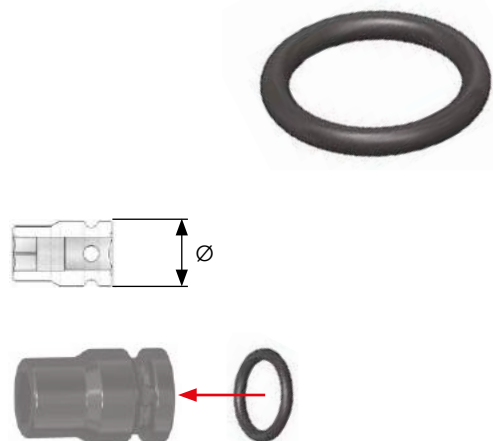

**EASYPACK** | sacchetto PVC con Euro-hole • PVC bags with Euro-hole

	Ø mm	PCS.	COD.	€ cad./each
1/4"	13	5	64999001	0,210
3/8"	19	5	64999002	0,270
3/8"	22	5	64999003	0,300
1/2"	25	5	64999004	0,430
1/2"	30	5	64999005	0,540
1/2"	35-38	5	64999006	0,700
3/4"	44	5	64999007	0,860
3/4" - 1"	54	5	64999008	1,000
1" - 1/2"	86	5	64999009	1,850
1" - 1/2"	127	5	64999010	3,830

## 64999 SPINA DI BLOCCAGGIO

SPINA DI BLOCCAGGIO PER BUSSOLE IMPACT  
IMPACT SOCKET RETAINING PIN  
GOUPILLES POUR DOUILLES IMPACT  
PASADOR DE RETENCION PARA VASOS IMPACT

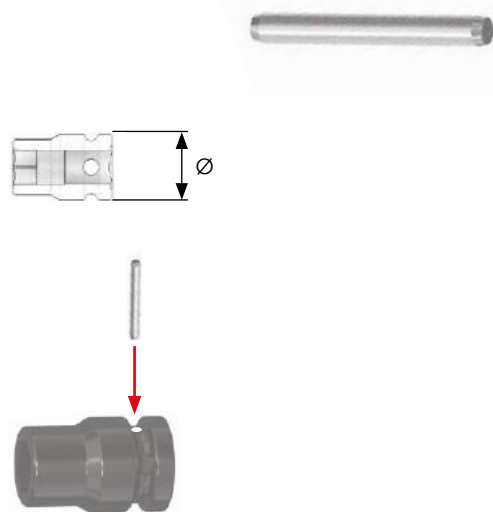

**EASYPACK** | sacchetto PVC con Euro-hole • PVC bags with Euro-hole

	Ø mm	PCS.	COD.	€ cad./each
1/4"	13	5	64999021	0,750
3/8"	19	5	64999022	0,750
3/8"	22	5	64999023	0,750
1/2"	25	5	64999024	0,750
1/2"	30	5	64999025	0,750
1/2"	35-38	5	64999026	0,810
3/4"	44	5	64999027	1,250
3/4" - 1"	54	5	64999028	1,750
1" - 1/2"	86	5	64999029	2,590
1" - 1/2"	127	5	64999030	2,680



*Vista di un impianto di estrazione petrolifero in alto mare*

*Offshore oil drilling platform.*

*Vue des une plateforme de forage petrolier.*

*Vista de una plataforma de perforacion petrolera.*

# CHROME

## BUSSOLE E ACCESSORI CHROME

CHROME sockets and accessories

Douilles et accessoires CHROME

Vasos y accesorios CHROME



Realizzate in acciaio al Cromo Vanadio di alta qualità. Collare godronato per una miglior presa e resistente rivestimento superficiale di cromatura.

Made in high quality Chrome-Vanadium steel. Knurled collar for better grip and resistant chrome-plated surface coating.

Réalisées en acier de chrome-vanadium de haute qualité. Collier moleté pour une meilleure adhérence et revêtement de surface résistant chromé.

Fabricadas con acero al Cromo Vanadio de alta calidad. Collar moleteado para un mejor agarre y recubrimiento superficial resistente cromado.



Impronta esagonale tipo SUPER- LOCK: il contatto con il dado non avviene sullo spigolo ma sulla faccia dell'esagono, che offre una maggior superficie di appoggio.

SUPER-LOCK hex tip: the contact with the nut does not take place on the edge, but on the face of the hexagon, which offers a larger support surface.

Empreinte 6 pans creux type SUPER-LOCK : le contact avec l'écrou ne se produit pas par l'angle, mais sur la face de l'hexagone, qui offre une plus grande surface d'appui.

Huella hexagonal tipo SUPER- LOCK: el contacto con la tuerca no se realiza sobre la arista, sino sobre la cara del hexágono, que ofrece una mayor superficie de apoyo.



Indicate per applicazioni manuali in ambito professionale.

Suitable for professional manual applications.

Convient pour les applications manuelles dans un environnement professionnel.

Aptas para aplicaciones manuales en ámbito profesional.





# 64008 SUPERLOCK 1/4"

BUSSOLE 1/4" CAVA ESAGONALE TIPO SUPER-LOCK  
 1/4" SOCKETS SUPER-LOCK HEXAGON RECESS  
 DOUILLES 1/4" HEXAGONALES CREUSES SUPER-LOCK  
 VASOS DE 1/4" CON CAVIDAD HEXAGONAL TIPO SUPER-LOCK

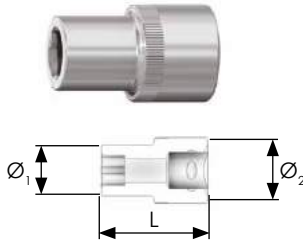

**EASYPACK** | sacchetto PVC con Euro-hole • PVC bags with Euro-hole

●	L mm	Ø <sub>1</sub> mm	Ø <sub>2</sub> mm	PCS.	COD.	€ cad./each
4	25	7	12	1	64008005	1,880
4,5	25	7,2	12	1	64008010	1,880
5	25	8	12	1	64008015	1,880
5,5	25	8,7	12	1	64008020	1,880
6	25	9,3	12	1	64008025	1,880
7	25	10,5	12	1	64008030	1,880
8	25	12	12	1	64008035	1,930
9	25	13	12	1	64008040	1,930
10	25	14	12	1	64008045	1,930
11	25	16	14	1	64008050	2,250
12	25	17	15	1	64008055	2,540
13	25	18	16	1	64008060	2,540
14	25	20	18	1	64008065	2,960

●	L mm	COD.	€ box
4	25	64008005001	3,220
4,5	25	64008010001	3,220
5	25	64008015001	3,220
5,5	25	64008020001	3,220
6	25	64008025001	3,220
7	25	64008030001	3,220
8	25	64008035001	3,270
9	25	64008040001	3,270
10	25	64008045001	3,270
11	25	64008050001	3,590
12	25	64008055001	3,870
13	25	64008060001	3,870
14	25	64008065001	4,300



**SELPACK**  
1 pc.





# 3 BUSSOLE E ACCESSORI

SOCKETS AND ACCESSORIES  
DOUILLES ET ACCESSOIRES  
VASOS Y ACCESORIOS

## 64009 ASSORTIMENTI SUPERLOCK 1/4"

SERIE 10 PCS. BUSSOLE 1/4" SUPER-LOCK  
10 PCS. SOCKETS SET 1/4" SUPER-LOCK  
JEU 10 PIÈCES DOUILLES 1/4" SUPER-LOCK  
JUEGO DE 10 PIEZAS DE VASOS DE 1/4" SUPER-LOCK



10  
pcs.

200 X 35 X 18 mm

COD. **64009005**

€ 25,500



5	5,5	6	7	8	9	10	11	12	13
1pc.	1pc.	1pc.	1pc.	1pc.	1pc.	1pc.	1pc.	1pc.	1pc.

## 66001 STORE 6 ASSORTIMENTI BUSSOLE E ACCESSORI

CASSETTIERA CON 6 SCOMPARTI PER ESPOSITORE MULTISTORE  
DRAWERS WITH 6 COMPARTMENTS FOR MULTISTORE DISPLAY  
TIROIRS AVEC 6 COMPARTIMENTS POUR PRESENTOIR MULTISTORE  
6 CAJONES PARA MOSTRADOR DE EXPOSICIÓN TIPO MULTISTORE



600 X 115 X 65 mm

105  
pcs.

COD. **66001110**

€ 173,000



5,5	7	8	10	13
20pcs.	20pcs.	20pcs.	20pcs.	20pcs.

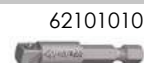

1/4"x1/4"x50mm  
5pcs.



### MULTI STORE

COD. 66001005VC

PER DETTAGLI E COMPOSIZIONE VEDERE P. 184  
FOR DETAILS AND COMPOSITION SEE P. 184  
POUR LES DÉTAILS ET LA COMPOSITION VOIR P. 184  
PARA MÁS DETALLES Y COMPOSICIÓN VÉASE P. 184



## 64149 BUSSOLE CON INSERTO TAGLIO

BUSSOLE 1/4" CON INSERTO A TAGLIO  
1/4" SOCKETS WITH SLOTTED BIT  
DOUILLES 1/4" AVEC EMBOUT À FENTE  
VASOS DE 1/4" CON PUNTA DE CORTE

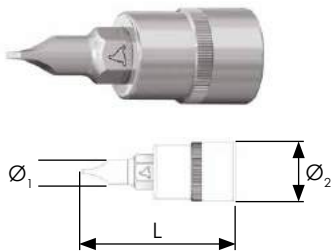

**EASYPACK** | sacchetto PVC con Euro-hole • PVC bags with Euro-hole

	Ø <sub>1</sub> mm	L mm	Ø <sub>2</sub> mm	PCS.	COD.	€ cad./each
0,6	4,0	32	12	1	64149005	2,880
0,8	5,5	32	12	1	64149010	2,880
1,2	7,0	32	12	1	64149015	2,880



SELFPACK  
1 pc.

	L mm	COD.	€ box
0,6	32	64149005001	4,220
0,8	32	64149010001	4,220
1,2	32	64149015001	4,220

## 64150 BUSSOLE CON INSERTO PH

BUSSOLE 1/4" CON INSERTO PHILLIPS®  
1/4" SOCKETS WITH PHILLIPS® BIT  
DOUILLES 1/4" AVEC EMBOUT PHILLIPS®  
VASOS DE 1/4" CON PUNTA PHILLIPS®

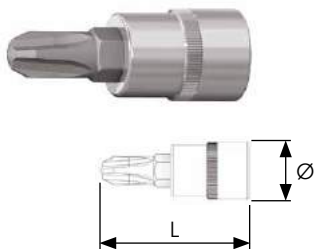

**EASYPACK** | sacchetto PVC con Euro-hole • PVC bags with Euro-hole

	L mm	Ø mm	PCS.	COD.	€ cad./each
PH1	32	12	1	64150005	2,660
PH2	32	12	1	64150010	2,660
PH3	36	12	1	64150015	2,660



SELFPACK  
1 pc.

	L mm	COD.	€ box
PH1	32	64150005001	3,990
PH2	32	64150010001	3,990
PH3	32	64150015001	3,990



# 3 BUSSOLE E ACCESSORI

SOCKETS AND ACCESSORIES  
DOUILLES ET ACCESSOIRES  
VASOS Y ACCESORIOS

## 64151 BUSSOLE CON INSERTO PZ

BUSSOLE 1/4" CON INSERTO POZIDRIV®  
1/4" SOCKETS WITH POZIDRIV® BIT  
DOUILLES 1/4" AVEC EMBOUT POZIDRIV®  
VASOS DE 1/4" CON PUNTA POZIDRIV®

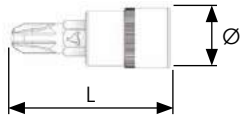

**EASYPACK** | sacchetto PVC con Euro-hole • PVC bags with Euro-hole

	L mm	Ø mm	PCS.	COD.	€ cad./each
PZ1	32	12	1	64151005	2,660
PZ2	32	12	1	64151010	2,660
PZ3	36	12	1	64151015	2,660



**SELPACK**  
1 pc.

	L mm	COD.	€ box
PZ1	32	64151005001	3,990
PZ2	32	64151010001	3,990
PZ3	32	64151015001	3,990

## 64147 BUSSOLE CON INSERTO TX

BUSSOLE 1/4" CON INSERTO PER VITI TORX®  
1/4" SOCKETS WITH BIT FOR TORX® SCREWS  
DOUILLES 1/4" AVEC EMBOUT POUR VIS TORX  
VASOS DE 1/4" CON PUNTA PARA TORNILLOS TORX®

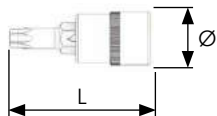

**EASYPACK** | sacchetto PVC con Euro-hole • PVC bags with Euro-hole

	L mm	Ø mm	PCS.	COD.	€ cad./each
TX10	32	12	5	64147005	2,880
TX15	32	12	5	64147010	2,880
TX20	32	12	5	64147015	2,880
TX25	32	12	5	64147020	2,880
TX27	32	12	5	64147025	2,880
TX30	32	12	5	64147030	2,880
TX40	32	12	5	64147035	2,880



**SELPACK**  
1 pc.

	L mm	COD.	€ box
TX10	32	64147005001	4,220
TX15	32	64147010001	4,220
TX20	32	64147015001	4,220
TX25	32	64147020001	4,220
TX27	32	64147025001	4,220
TX30	32	64147030001	4,220
TX40	32	64147035001	4,220



# 64145 BUSSOLE CON INSERTO ESAGONALE

BUSSOLE 1/4" CON INSERTO ESAGONALE  
1/4" SOCKETS WITH HEXAGONAL BIT  
DOUILLES 1/4" AVEC EMBOUT HEXAGONAL  
VASOS DE 1/4" CON PUNTA HEXAGONAL

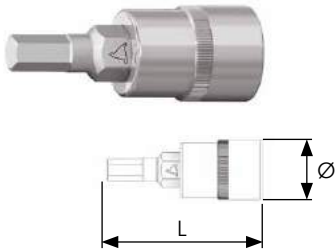

EASYPACK | sacchetto PVC con Euro-hole • PVC bags with Euro-hole

Ø	L mm	Ø mm	PCS.	COD.	€ cad./each
3	32	12	5	64145005	2,880
4	32	12	5	64145010	2,880
5	32	12	5	64145015	2,880
6	32	12	5	64145020	2,880
7	32	12	5	64145025	2,880
8	32	12	5	64145030	2,880



SELPACK  
1 pc.

Ø	L mm	COD.	€ box
3	32	64145005001	4,220
4	32	64145010001	4,220
5	32	64145015001	4,220
6	32	64145020001	4,220
7	32	64145025001	4,220
8	32	64145030001	4,220

# 64148 ASSORTIMENTI BUSSOLE 1/4" CON INSERTO

ASSORTIMENTI BUSSOLE 1/4" CON INSERTO  
1/4" SOCKETS SETS WITH BIT  
JEU DOUILLES 1/4" AVEC EMBOUT  
JUEGO DE VASOS DE 1/4" CON PUNTA



200 X 46 X 13 mm

7  
pcs.

COD. **64148005**  
€ 24,400



TX10 1pc.	TX15 1pc.	TX20 1pc.	TX25 1pc.	TX27 1pc.	TX30 1pc.	TX40 1pc.
--------------	--------------	--------------	--------------	--------------	--------------	--------------



200 X 46 X 13 mm

6  
pcs.

COD. **64148010**  
€ 20,900



3 1pc.	4 1pc.	5 1pc.	6 1pc.	7 1pc.	8 1pc.
-----------	-----------	-----------	-----------	-----------	-----------



# 3 BUSSOLE E ACCESSORI

SOCKETS AND ACCESSORIES  
DOUILLES ET ACCESSOIRES  
VASOS Y ACCESORIOS

## 62173 PROLUNGHE CON SFERA

PROLUNGA PER BUSSOLE 1/4"  
EXTENSION FOR 1/4" SOCKETS  
RALLONGE POUR DOUILLES 1/4"  
EXTENSIÓN PARA VASOS DE 1/4"

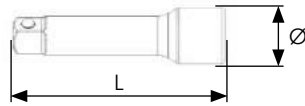
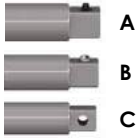

**EASYPACK** | sacchetto PVC con Euro-hole • PVC bags with Euro-hole

L mm	A/B/C	Ø mm	PCS.	COD.	€ cad./each
50	B	12	5	62173005	2,680
150	B	12	5	62173010	4,690



**SELPACK**  
1 pc.

L mm	COD.	€ box
50	62173005001	4,020
150	62173010001	6,030

## 62174 PROLUNGHE SNODATE

PROLUNGA PER BUSSOLE 1/4" SNODATA  
UNIVERSAL JOINT FOR 1/4" SOCKETS  
RALLONGE POUR DOUILLES 1/4" ARTICULÉE  
EXTENSIÓN PARA VASOS DE 1/4" CON ARTICULACIÓN

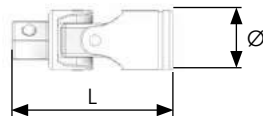
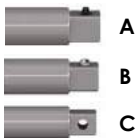

**EASYPACK** | sacchetto PVC con Euro-hole • PVC bags with Euro-hole

L mm	A/B/C	Ø mm	PCS.	COD.	€ cad./each
40	B	12	1	62174005	5,900



**SELPACK**  
1 pc.

L mm	COD.	€ box
40	62174005001	7,230



## 62115 ADATTATORI PER BUSSOLE 3/8"

ADATTATORE/AUMENTATORE 1/4" PER BUSSOLE DA 3/8"  
1/4" ADAPTER/ENHANCER FOR 3/8" SOCKETS  
ADAPTATEUR/AUGMENTATEUR 1/4" POUR DOUILLES DE 3/8"  
ADAPTADOR/EXTENSOR DE 1/4" PARA VASOS DE 3/8"

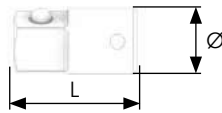
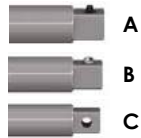

**EASYPACK** | sacchetto PVC con Euro-hole • PVC bags with Euro-hole

L mm	A/B/C	Ø mm	PCS.	COD.	€ cad./each
26	B	13	1	62115001	3,816



**SELPACK**  
1 pc.

L mm	COD.	€ box
26	62115001001	5,155

## 64220 BARRE A "T"

LEVA PER BUSSOLE CON ASTA MOBILE  
LEVER FOR SOCKETS WITH MOBILE ROD  
LEVIER POUR DOUILLE AVEC TIGE MOBILE  
PALANCA PARA VASOS CON VARILLA MÓVIL

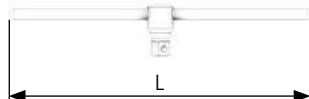
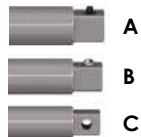

L mm	A/B/C	PCS.	COD.	€ cad./each
115	B	1	64220005	7,370



**SELPACK**  
1 pc.

L mm	COD.	€ box
115	64220005001	8,710

## 65999 GIRAVITE PORTABUSSOLE

GIRAVITE PORTABUSSOLE PER 1/4"  
SOCKET-HOLDER SCREWDRIVER FOR 1/4"  
TOURNEVIS PORTE-DOUILLES POUR 1/4"  
DESTORNILLADOR PORTA LLAVES DE VASO PARA 1/4"

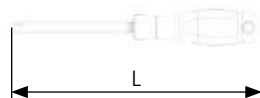
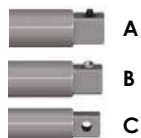

L mm	A/B/C	PCS.	COD.	€ cad./each
145	B	1	65999002	7,230





# 3 BUSSOLE E ACCESSORI

SOCKETS AND ACCESSORIES  
DOUILLES ET ACCESSOIRES  
VASOS Y ACCESORIOS

**64221**

## CRICCHETTI REVERSIBILI 72 DENTI

CRICCHETTO REVERSIBILE 72T  
72 REVERSIBLE RATCHET  
CLIQUET RÉVERSIBLE 72T  
CARRACA RÉVERSIBLE 72T

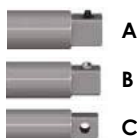

L mm	A/B/C	PCS.	COD.	€ cad./each
145	B	1	64221005	26,500



**64221**

## CRICCHETTI REVERSIBILI 45 DENTI

CRICCHETTO REVERSIBILE 45T  
45T REVERSIBLE RATCHET  
CLIQUET RÉVERSIBLE 45T  
CARRACA RÉVERSIBLE 45T

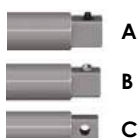

L mm	A/B/C	PCS.	COD.	€ cad./each
160	B	1	64221006	14,000



**NEW!**

**64221**

## MINI-CRICCHETTI DOPPIA FUNZIONE

MINI-CRICCHETTO REVERSIBILE PER INSERTI E PER BUSSOLE  
REVERSIBLE MINI-RATCHET FOR BITS AND SOCKETS  
MINI-CLIQUET RÉVERSIBLE POUR EMBOUTS ET DOUILLES  
MINI LLAVE DE TRINQUETE REVERSIBLE PARA PUNTAS Y VASOS

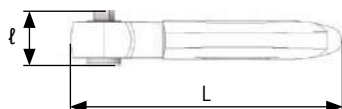
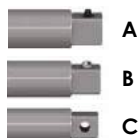

L mm	A/B/C	PCS.	COD.	€ cad./each
105	B	1	64221020	20,400

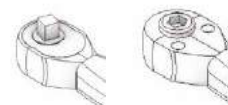





## 64221 CRICCHETTI ONE-TOUCH

CRICCHETTO REVERSIBILE SISTEMA ONE-TOUCH  
REVERSIBLE RATCHET ONE-TOUCH SYSTEM  
CLIQUET RÉVERSIBLE SYSTÈME ONE-TOUCH  
CARRACA REVERSIBLE SISTEMA ONE-TOUCH

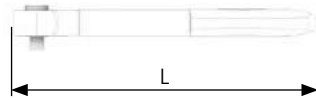
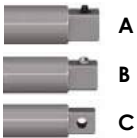

L mm	A/B/C	PCS.	COD.	€ cad./each
150	B	1	64221010	21,600



### FOCUS ON



Movimento a 60 denti, ghiera di inversione della rotazione direttamente sul manico.  
Movement with 60 teeth, reversal of the rotation of the ring nut directly on the handle.  
Mouvement à 60 dents, bague d'inversion de la rotation directement sur la poignée.  
Movimiento de 60 dientes, abrazadera de inversión de la rotación directamente sobre el mango.



## 64221 CRICCHETTI TELESCOPICI

CRICCHETTO REVERSIBILE CON ASTA TELESCOPICA  
REVERSIBLE RATCHET WITH TELESCOPIC ROD  
CLIQUET RÉVERSIBLE AVEC TIGE TÉLESCOPIQUE  
CARRACA REVERSIBLE CON ASTA TELESCÓPICA

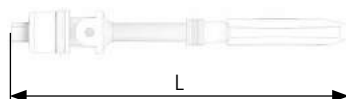
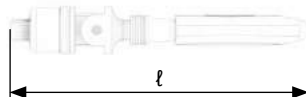
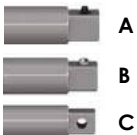

L mm	l mm	A/B/C	PCS.	COD.	€ cad./each
245	197	B	1	64221015	27,000



### FOCUS ON



Movimento a 36 denti, testa snodata ad alta resistenza, braccio telescopico.  
Movement with 36 teeth, high-resistance jointed head, telescopic arm.  
Mouvement à 36 dents, tête articulée haute résistance, bras télescopique.  
Movimiento de 36 dientes, cabeza articulada de alta resistencia, brazo telescópico.





# 3 BUSSOLE E ACCESSORI

SOCKETS AND ACCESSORIES  
DOUILLES ET ACCESSOIRES  
VASOS Y ACCESORIOS

**64026**

**SUPERLOCK 3/8"**

BUSSOLE 3/8" CAVA ESAGONALE TIPO SUPER-LOCK  
3/8" SUPER-LOCK HEXAGONAL RECESS SOCKETS  
DOUILLES 3/8" HEXAGONALES CREUSES SUPER-LOCK  
VASOS DE 3/8" CON CAVIDAD HEXAGONAL TIPO SUPER-LOCK

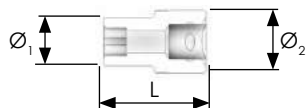

**EASYPACK** | sacchetto PVC con Euro-hole • PVC bags with Euro-hole

	L mm	Ø <sub>1</sub> mm	Ø <sub>2</sub> mm	PCS.	COD.	€ cad./each
<b>7</b>	28	10,5	17	5	64026005	2,790
<b>8</b>	28	12	17	5	64026010	2,790
<b>10</b>	28	14,5	17	5	64026015	2,790
<b>11</b>	28	16	17	5	64026020	2,790
<b>12</b>	28	17	17	5	64026025	3,140
<b>13</b>	28	18	17	5	64026030	3,140
<b>14</b>	28	20	17	5	64026035	3,490
<b>15</b>	28	22	19	5	64026040	3,830
<b>17</b>	30	24	20	5	64026045	5,050
<b>19</b>	30	26	23	5	64026050	5,050
<b>21</b>	32	28	25	5	64026055	6,620
<b>22</b>	32	30	26	5	64026060	6,780
<b>24</b>	32	32	28	5	64026065	7,900

	L mm	COD.	€ box
<b>7</b>	28	64026005001	4,130
<b>8</b>	28	64026010001	4,130
<b>10</b>	28	64026015001	4,130
<b>11</b>	28	64026020001	4,130
<b>12</b>	28	64026025001	4,480
<b>13</b>	28	64026030001	4,480
<b>14</b>	28	64026035001	4,820
<b>15</b>	28	64026040001	5,170
<b>17</b>	30	64026045001	6,390
<b>19</b>	30	64026050001	6,390
<b>21</b>	32	64026055001	7,960
<b>22</b>	32	64026060001	8,120
<b>24</b>	32	64026065001	9,240



**SELPACK**  
1 pc.



# 64027 ASSORTIMENTI SUPERLOCK 3/8"

SERIE 8 PCS. BUSSOLE 3/8" SUPER-LOCK  
8 PCS. SOCKETS SET 3/8" SUPER-LOCK  
JEU 8 PIÈCES DOUILLES 3/8" SUPER-LOCK  
JUEGO DE 8 PIEZAS DE VASOS DE 3/8" SUPER-LOCK



200 X 35 X 18 mm

8 pcs.

COD. **64027005**  
€ 36,400



7	8	10	13	15	17	19	21
1pc.	1pc.	1pc.	1pc.	1pc.	1pc.	1pc.	1pc.

# 66001 STORE 6 ASSORTIMENTI BUSSOLE E ACCESSORI

CASSETTIERA CON 6 SCOMPARTI PER ESPOSITORE MULTISTORE  
DRAWERS WITH 6 COMPARTMENTS FOR MULTISTORE DISPLAY  
TIROIRS AVEC 6 COMPARTIMENTS POUR PRESENTOIR MULTISTORE  
6 CAJONES PARA MOSTRADOR DE EXPOSICIÓN TIPO MULTISTORE



600 X 115 X 65 mm

105 pcs.

COD. **66001115**  
€ 272,000



7	8	10	13	17
20pcs.	20pcs.	20pcs.	20pcs.	20pcs.

62111010

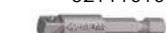

1/4"x3/8"x50mm  
5pcs.



## MULTI STORE

COD. 66001005VC

PER DETTAGLI E COMPOSIZIONE VEDERE P. 184  
FOR DETAILS AND COMPOSITION SEE P. 184  
POUR LES DÉTAILS ET LA COMPOSITION VOIR P. 184  
PARA MÁS DETALLES Y COMPOSICIÓN VÉASE P. 184



# 3 BUSSOLE E ACCESSORI

SOCKETS AND ACCESSORIES  
DOUILLES ET ACCESSOIRES  
VASOS Y ACCESORIOS

**64163**

## BUSSOLE CON INSERTO TX

BUSSOLE 3/8" CON INSERTO PER VITI TORX®  
3/8" SOCKETS WITH BIT FOR TORX® SCREWS  
DOUILLES 3/8" AVEC EMBOUT POUR VIS TORX  
VASOS DE 3/8" CON PUNTA PARA TORNILLOS TORX®

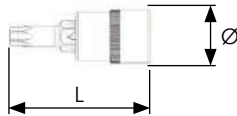

**EASYPACK** | sacchetto PVC con Euro-hole • PVC bags with Euro-hole

	L mm	Ø mm	PCS.	COD.	€ cad./each
<b>TX20</b>	48	17	5	64163005	5,760
<b>TX25</b>	48	17	5	64163010	5,760
<b>TX27</b>	48	17	5	64163015	5,760
<b>TX30</b>	48	17	5	64163020	5,760
<b>TX40</b>	48	17	5	64163025	5,760
<b>TX45</b>	48	17	5	64163030	5,760
<b>TX50</b>	48	17	5	64163035	5,760



L mm

COD.

€  
box

<b>TX20</b>	48	64163005001	7,100
<b>TX25</b>	48	64163010001	7,100
<b>TX27</b>	48	64163015001	7,100
<b>TX30</b>	48	64163020001	7,100
<b>TX40</b>	48	64163025001	7,100
<b>TX45</b>	48	64163030001	7,100
<b>TX50</b>	48	64163035001	7,100



**SELFPACK**  
1 pc.

**64161**

## BUSSOLE CON INSERTO ESAGONALE

BUSSOLE 3/8" CON INSERTO ESAGONALE  
3/8" SOCKETS WITH HEXAGONAL BIT  
DOUILLES 3/8" AVEC EMBOUT HEXAGONAL  
VASOS DE 3/8" CON PUNTA HEXAGONAL

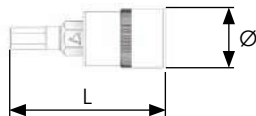

**EASYPACK** | sacchetto PVC con Euro-hole • PVC bags with Euro-hole

	L mm	Ø mm	PCS.	COD.	€ cad./each
<b>3</b>	48	17	5	64161005	5,760
<b>4</b>	48	17	5	64161010	5,760
<b>5</b>	48	17	5	64161015	5,760
<b>6</b>	48	17	5	64161020	5,760
<b>8</b>	48	17	5	64161025	5,760
<b>10</b>	48	17	5	64161030	5,760



L mm

COD.

€  
box

<b>3</b>	48	64161005001	7,100
<b>4</b>	48	64161010001	7,100
<b>5</b>	48	64161015001	7,100
<b>6</b>	48	64161020001	7,100
<b>8</b>	48	64161025001	7,100
<b>10</b>	48	64161030001	7,100



**SELFPACK**  
1 pc.



## 64162 ASSORTIMENTI BUSSOLE 3/8" CON INSERTO

ASSORTIMENTI BUSSOLE 3/8" CON INSERTO  
3/8" SOCKETS SETS WITH BIT  
JEU DOUILLES 3/8" AVEC EMBOUT  
JUEGO DE VASOS DE 3/8" CON PUNTA



6  
pcs.

200 X 46 X 13 mm

COD. **64162005**  
€ 41,000



3	4	5	6	8	10
1pc.	1pc.	1pc.	1pc.	1pc.	1pc.



7  
pcs.

200 X 46 X 13 mm

COD. **64162010**  
€ 48,000



TX20	TX25	TX27	TX30	TX40	TX45	TX50
1pc.	1pc.	1pc.	1pc.	1pc.	1pc.	1pc.

## 64162 BUSSOLE MORTORQ- SUPER®

ASSORTIMENTO 5 PCS. BUSSOLE 3/8" CON INSERTO MORTORQ-SUPER®  
5 PCS 3/8" SOCKETS SET WITH MORTORQ-SUPER® BITS  
JEU 5 PCS DOUILLES 3/8" AVEC EMBOUTS MORTORQ-SUPER®  
JUEGO 5 PCS VASOS DE 3/8" CON PUNTAS MORTORQ-SUPER®



5  
pcs.

130 X 60 X 20 mm

COD. **64162100**  
€ 46,400



MTS0	MTS1	MTS2	MTS3	MTS4
1pc.	1pc.	1pc.	1pc.	1pc.





# 3 BUSSOLE E ACCESSORI

SOCKETS AND ACCESSORIES  
DOUILLES ET ACCESSOIRES  
VASOS Y ACCESORIOS

## 64201 ESTRATTORI BULLONI

ESTRATTORI 3/8" E 1/2" PER DADI E BULLONI  
3/8" AND 1/2" EXTRACTORS FOR NUTS AND BOLTS  
EXTRACTEURS 3/8 "ET 1/2" POUR BOULONS  
EXTRACTORES DE 3/8" Y DE 1/2" PARA TUERCAS Y DADOS

40/44 HRC



**EASYPACK** | sacchetto PVC con Euro-hole • PVC bags with Euro-hole

		L mm	PCS.	COD.	€ cad./each
3/8"	8	32	1	64201005	14,200
3/8"	10	32	1	64201010	14,200
3/8"	11	32	1	64201015	14,200
3/8"	12	32	1	64201020	14,200
3/8"	13	32	1	64201025	15,100
3/8"	14	32	1	64201030	16,600
1/2"	15	34	1	64201035	17,100
1/2"	16	34	1	64201040	17,100
1/2"	17	34	1	64201045	18,600
1/2"	18	34	1	64201050	19,800
1/2"	19	34	1	64201055	19,800

## 64202 ASSORTIMENTI ESTRATTORI BULLONI

ASSORTIMENTO 11 PCS. ESTRATTORI  
11 PCS. EXTRACTORS SET  
JEU DE 11 PIÈCES EXTRACTEURS  
JUEGO DE 11 PIEZAS DE EXTRACTORES



11  
pcs.

340 X 50 X 50 mm

COD. **64202005**  
€ 150,000

64201

8	10	11	12	13	14	15	16	17	18	19
1pc.	1pc.	1pc.	1pc.	1pc.	1pc.	1pc.	1pc.	1pc.	1pc.	1pc.

## 64198 BUSSOLE PORTA-MASCHI

BUSSOLE 3/8" CON MANDRINO PORTA-MASCHI  
3/8" SOCKETS WITH TAP-HOLDER CHUCK  
DOUILLES 3/8" AVEC MANDRIN PORTE-TARAUDS  
VASOS DE 3/8" CON MANDRIL PORTA-MACHOS



**EASYPACK** | sacchetto PVC con Euro-hole • PVC bags with Euro-hole

	L mm	PCS.	COD.	€ cad./each
M3-M8	40	1	64198005	24,100
M6-M12	50	1	64198010	25,100



3/8"



## 64199 BUSSOLE PORTA-FILIERE

BUSSOLE 3/8" PORTAFILIERE CON GRANI DI BLOCCO  
 3/8" DIE-HOLDER SOCKETS WITH GRAIN LOCKING  
 DOUILLES 3/8 " PORTE-FILIÈRES AVEC DES GOUJONS DE BLOCAGE  
 VASOS DE 3/8" PORTA ROSCAS CON MUESCAS DE BLOQUEO



3/8"

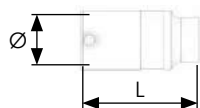

**EASYPACK** | sacchetto PVC con Euro-hole • PVC bags with Euro-hole

Ø mm	L mm	PCS.	COD.	€ cad./each
20	70	1	64199005	12,600
25,4	70	1	64199010	15,600
30	70	1	64199015	17,600
38,1	70	1	64199020	19,900

## 64200 ESTRATTORI BULLONI DANNEGGIATI

ESTRATTORI 3/8" PER DADI E BULLONI DANNEGGIATI  
 3/8" EXTRACTORS FOR DAMAGED NUTS AND BOLTS  
 EXTRACTEURS 3/8" POUR BOULONS ABIMÉES  
 EXTRACTORES DE 3/8" PARA TUERCAS Y DADOS DAÑADOS



3/8"



**EASYPACK** | sacchetto PVC con Euro-hole • PVC bags with Euro-hole

Ø	L mm	PCS.	COD.	€ cad./each
8	30	1	64200005	6,160
10	30	1	64200010	6,160
13	30	1	64200015	6,430
17	30	1	64200020	7,900

## 66036 SET ESTRATTORI 3/8" PER BULLONI

ASSORTIMENTO 4 PCS. ESTRATTORI PER DADI E BULLONI  
 4 PCS. NUTS AND BOLTS EXTRACTORS SET  
 JEU DE 4 PCS. EXTRACTEURS POUR BOULONS  
 JUEGO DE 4 PCS. DE EXTRACTORES PARA TUERCAS Y DADOS



4  
pcs.

COD. **66036005**  
 € 26,000

64200

8 1pc.	10 1pc.	13 1pc.	17 1pc.
-----------	------------	------------	------------

65 X 105 X 45 mm



# 3 BUSSOLE E ACCESSORI

SOCKETS AND ACCESSORIES  
DOUILLES ET ACCESSOIRES  
VASOS Y ACCESORIOS

## 62185 PROLUNGHE CON SFERA

PROLUNGA PER BUSSOLE 3/8"  
EXTENSION FOR 3/8" SOCKETS  
RALLONGE POUR DOUILLES 3/8"  
EXTENSIÓN PARA VASOS DE 3/8"

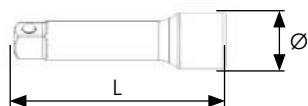
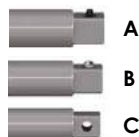

**EASYPACK** | sacchetto PVC con Euro-hole • PVC bags with Euro-hole

L mm	A/B/C	Ø mm	PCS.	COD.	€ cad./each
45	B	17	5	62185005	3,890
150	B	17	5	62185010	6,970



**SELPACK**  
1 pc.

L mm	COD.	€ box
45	62185005001	5,230
150	62185010001	8,310

## 62186 PROLUNGHE SNODATE

PROLUNGA PER BUSSOLE 3/8" SNODATA  
EXTENSION FOR 3/8" ARTICULATED SOCKETS  
RALLONGE POUR DOUILLES 3/8" ARTICULÉE  
EXTENSIÓN PARA VASOS DE 3/8" CON ARTICULACIÓN

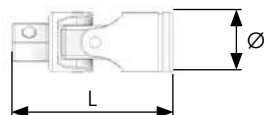
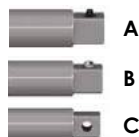

**EASYPACK** | sacchetto PVC con Euro-hole • PVC bags with Euro-hole

L mm	A/B/C	Ø mm	PCS.	COD.	€ cad./each
56	B	17	5	62186005	7,230



**SELPACK**  
1 pc.

L mm	COD.	€ box
56	62186005001	8,570





## 62104 RIDUZIONI PER BUSSOLE 1/4"

RIDUZIONE 3/8" PER BUSSOLE DA 1/4"  
3/8" REDUCTION FOR 1/4" SOCKETS  
RÉDUCTION 3/8" POUR DOUILLES DE 1/4"  
REDUCTOR DE 3/8" PARA VASOS DE 1/4"

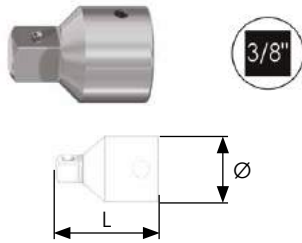
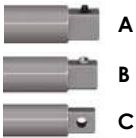

**EASYPACK** | sacchetto PVC con Euro-hole • PVC bags with Euro-hole

L mm	A/B/C	Ø mm	PCS.	COD.	€ cad./each
27	B	17	1	62104001	3,820

## 62124 ADATTATORI PER BUSSOLE 1/2"

ADATTATORE/AUMENTATORE 3/8" PER BUSSOLE DA 1/2"  
3/8" ADAPTER/ENHANCER FOR 1/2" SOCKETS  
ADAPTATEUR/AUGMENTATEUR 3/8" POUR DOUILLES DE 1/2"  
ADAPTADOR/EXTENSOR DE 3/8" PARA VASOS DE 1/2"

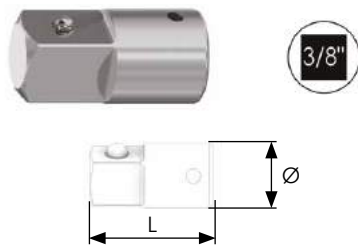
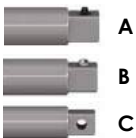

**EASYPACK** | sacchetto PVC con Euro-hole • PVC bags with Euro-hole

L mm	A/B/C	Ø mm	PCS.	COD.	€ cad./each
36	B	18	1	62124001	4,220



**SELPACK**  
1 pc.

L mm	COD.	€ box
36	62124001001	5,560



# 3 BUSSOLE E ACCESSORI

SOCKETS AND ACCESSORIES  
DOUILLES ET ACCESSOIRES  
VASOS Y ACCESORIOS

**64222**

## CRICCHETTI A "T"

CRICCHETTO REVERSIBILE PER 3/8" CON IMPUGNATURA A "T"  
REVERSIBLE RATCHET FOR 3/8" WITH T-SHAPED HANDLE  
CLIQUET RÉVERSIBLE POUR 3/8" AVEC POIGNÉE EN "T"  
CARRACA REVERSIBLE PARA 3/8" CON MANGO A FORMA DE "T"

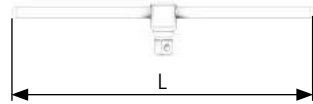
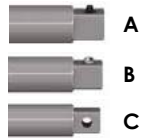

L mm	A/B/C	PCS.	COD.	€ cad./each
200	B	5	64222005	32,000



SELFPACK  
1 pc.

L mm	COD.	€ box
200	64222005001	33,000

**64223**

## CRICCHETTI REVERSIBILI 72 DENTI

CRICCHETTO REVERSIBILE 72T  
72 REVERSIBLE RATCHET  
CLIQUET RÉVERSIBLE 72T  
CARRACA REVERSIBLE 72T

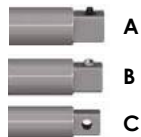

L mm	A/B/C	PCS.	COD.	€ cad./each
200	B	1	64223005	28,800



**64223**

## CRICCHETTI REVERSIBILI 45 DENTI

CRICCHETTO REVERSIBILE 45T  
45T REVERSIBLE RATCHET  
CLIQUET RÉVERSIBLE 45T  
CARRACA REVERSIBLE 45T

**NEW!**

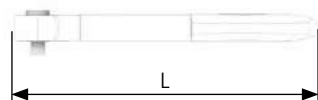
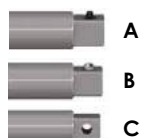

L mm	A/B/C	PCS.	COD.	€ cad./each
205	B	1	64223006	18,000





## 64223 CRICCHETTI ONE-TOUCH

CRICCHETTO REVERSIBILE SISTEMA ONE-TOUCH  
REVERSIBLE RATCHET ONE-TOUCH SYSTEM  
CLIQUET RÉVERSIBLE SYSTÈME ONE-TOUCH  
CARRACA REVERSIBLE PARA CON SISTEMA ONE-TOUCH

3/8"

60T

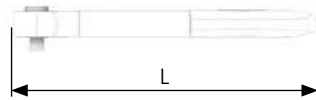
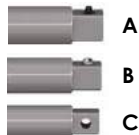

L mm	A/B/C	PCS.	COD.	€ cad./each
200	B	1	64223010	40,700



### FOCUS ON



Movimento a 60 denti, ghiera di inversione della rotazione direttamente sul manico.  
Movement with 60 teeth, reversal of the rotation of the ring nut directly on the handle.  
Mouvement à 60 dents, bague d'inversion de la rotation directement sur la poignée.  
Movimiento de 60 dientes, abrazadera de inversión de la rotación directamente sobre el mango.



## 64223 CRICCHETTI TELESCOPICI

CRICCHETTO REVERSIBILE CON ASTA TELESCOPICA  
REVERSIBLE RATCHET WITH TELESCOPIC ROD  
CLIQUET RÉVERSIBLE AVEC TIGE TÉLESCOPIQUE  
CARRACA REVERSIBLE CON ASTA TELESCÓPICA

3/8"

36T

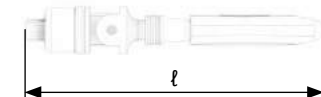
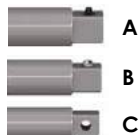

L mm	l mm	A/B/C	PCS.	COD.	€ cad./each
375	273	B	1	64223015	32,800



### FOCUS ON



Movimento a 36 denti, testa snodata ad alta resistenza, braccio telescopico.  
Movement with 36 teeth, high-resistance jointed head, telescopic arm.  
Mouvement à 36 dents, tête articulée haute résistance, bras télescopique.  
Movimiento de 36 dientes, cabeza articulada de alta resistencia, brazo telescópico.





# 3 BUSSOLE E ACCESSORI

SOCKETS AND ACCESSORIES  
DOUILLES ET ACCESSOIRES  
VASOS Y ACCESORIOS

**64048**

**SUPERLOCK 1/2"**

BUSSOLE 1/2" CAVA ESAGONALE TIPO SUPER-LOCK  
1/2" SOCKETS SUPER-LOCK HEXAGON RECESS  
DOUILLES 1/2" HEXAGONALES CREUSES SUPER-LOCK  
VASOS DE 1/2" CON CAVIDAD HEXAGONAL TIPO SUPER-LOCK

40/44 HRC

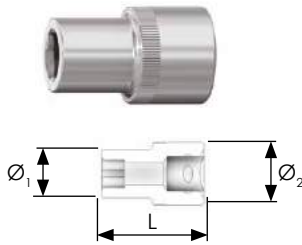

**EASYPACK** | sacchetto PVC con Euro-hole • PVC bags with Euro-hole

●	L mm	Ø <sub>1</sub> mm	Ø <sub>2</sub> mm	PCS.	COD.	€ cad./each
10	38	15,5	22	5	64048005	3,740
11	38	16,5	22	5	64048010	3,740
12	38	18	22	5	64048015	3,740
13	38	19,5	22	5	64048020	3,740
14	38	20,2	22	5	64048025	3,740
15	38	22	22	5	64048030	4,220
16	38	24	22	5	64048035	4,220
17	38	24	22	5	64048040	4,460
18	38	26	24	5	64048045	5,090
19	38	26	24	5	64048050	5,090
20	38	28	25	5	64048055	5,350
21	38	30	25	5	64048060	5,600
22	38	30	26	5	64048065	6,240
23	38	32	28	5	64048070	6,500
24	38	32	28	5	64048075	6,500
27	38	36	32	5	64048080	11,700
30	38	40	34	5	64048085	12,400
32	38	42	36	5	64048090	13,600

●	L mm	COD.	€ box
10	38	64048005001	5,080
11	38	64048010001	5,080
12	38	64048015001	5,080
13	38	64048020001	5,080
14	38	64048025001	5,080
15	38	64048030001	5,560
16	38	64048035001	5,560
17	38	64048040001	5,800
18	38	64048045001	6,430
19	38	64048050001	6,430
20	38	64048055001	6,690
21	38	64048060001	6,940
22	38	64048065001	7,580
23	38	64048070001	7,840
24	38	64048075001	7,840
27	38	64048080001	13,000
30	38	64048085001	13,800
32	38	64048090001	14,900



**SELFPACK**  
1 pc.

**64049**

**ASSORTIMENTI SUPERLOCK 1/2"**

SERIE 8 PCS. BUSSOLE 1/2" SUPER-LOCK  
8 PCS. SOCKETS SET 1/2" SUPER-LOCK  
JEU 8 PIÈCES DOUILLES 1/2" SUPER-LOCK  
JUEGO DE 8 PIEZAS DE VASOS DE 1/2" SUPER-LOCK

COD. **64049005**

€ 47,200

8  
pcs.



200 X 35 X 18 mm

64048

10	13	15	16	17	18	19	21
1pc.	1pc.	1pc.	1pc.	1pc.	1pc.	1pc.	1pc.



# 64171 BUSSOLE CON INSERTO ESAGONALE

BUSSOLE 1/2" CON INSERTO ESAGONALE  
1/2" SOCKETS WITH HEXAGON BIT  
DOUILLES 1/2" AVEC EMBOUT HEXAGONAL  
VASOS DE 1/2" CON CAVIDAD HEXAGONAL

40/44 HRC

EASYPACK | sacchetto PVC con Euro-hole • PVC bags with Euro-hole

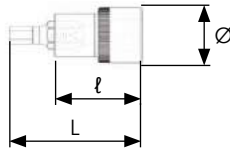

Ø	L mm	l mm	Ø mm	PCS.	COD.	€ cad./each
4	60	38	22	5	64171005	7,400
4	100	38	22	5	64171010	8,680
5	60	38	22	5	64171015	7,400
5	100	38	22	5	64171020	8,680
6	60	38	22	5	64171025	7,400
6	100	38	22	5	64171030	8,680
7	60	38	22	5	64171035	7,400
7	100	38	22	5	64171040	8,680
8	60	38	22	5	64171045	7,400
8	100	38	22	5	64171050	8,680
10	60	38	22	5	64171055	7,400
10	100	38	22	5	64171060	8,680
12	60	38	22	5	64171065	7,400
12	100	38	22	5	64171070	8,680
14	60	38	22	5	64171075	7,400
14	100	38	22	5	64171080	8,680

Ø	L mm	COD.	€ box
4	60	64171005001	8,730
4	100	64171010001	10,100
5	60	64171015001	8,730
5	100	64171020001	10,100
6	60	64171025001	8,730
6	100	64171030001	10,100
7	60	64171035001	8,730
7	100	64171040001	10,100
8	60	64171045001	8,730
8	100	64171050001	10,100
10	60	64171055001	8,730
10	100	64171060001	10,100
12	60	64171065001	8,730
12	100	64171070001	10,100
14	60	64171075001	8,730
14	100	64171080001	10,100



SELFPACK  
1 pc.





# 3 BUSSOLE E ACCESSORI

SOCKETS AND ACCESSORIES  
DOUILLES ET ACCESSOIRES  
VASOS Y ACCESORIOS

**64172**

## BUSSOLE CON INSERTO TX

BUSSOLE 1/2" CON INSERTO PER VITI TORX®  
1/2" SOCKETS WITH BIT FOR TORX® SCREWS  
DOUILLES 1/2" AVEC EMBOUT POUR VIS TORX®  
VASOS DE 1/2" CON PUNTA PARA TORNILLOS TORX®

40/44 HRC

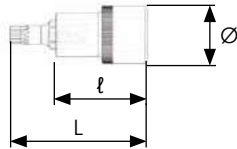

**EASYPACK** | sacchetto PVC con Euro-hole • PVC bags with Euro-hole

	L mm	l mm	Ø mm	PCS.	COD.	€ cad./each
<b>TX10</b>	60	38	22	5	64172005	7,400
<b>TX10</b>	100	38	22	5	64172010	8,680
<b>TX15</b>	60	38	22	5	64172015	7,400
<b>TX15</b>	100	38	22	5	64172020	8,680
<b>TX20</b>	60	38	22	5	64172025	7,400
<b>TX20</b>	100	38	22	5	64172030	8,680
<b>TX25</b>	60	38	22	5	64172035	7,400
<b>TX25</b>	100	38	22	5	64172040	8,680
<b>TX27</b>	60	38	22	5	64172045	7,400
<b>TX27</b>	100	38	22	5	64172050	8,680
<b>TX30</b>	60	38	22	5	64172055	7,400
<b>TX30</b>	100	38	22	5	64172060	8,680
<b>TX40</b>	60	38	22	5	64172065	7,400
<b>TX40</b>	100	38	22	5	64172070	8,680
<b>TX45</b>	60	38	22	5	64172075	7,400
<b>TX45</b>	100	38	22	5	64172080	8,680
<b>TX50</b>	60	38	22	5	64172085	7,400
<b>TX50</b>	100	38	22	5	64172090	8,680
<b>TX55</b>	60	38	22	5	64172095	7,400
<b>TX55</b>	100	38	22	5	64172100	8,680

	L mm	COD.	€ box
<b>TX10</b>	60	64172005001	8,730
<b>TX10</b>	100	64172010001	10,100
<b>TX15</b>	60	64172015001	8,730
<b>TX15</b>	100	64172020001	10,100
<b>TX20</b>	60	64172025001	8,730
<b>TX20</b>	100	64172030001	10,100
<b>TX25</b>	60	64172035001	8,730
<b>TX25</b>	100	64172040001	10,100
<b>TX27</b>	60	64172045001	8,730
<b>TX27</b>	100	64172050001	10,100
<b>TX30</b>	60	64172055001	8,730
<b>TX30</b>	100	64172060001	10,100
<b>TX40</b>	60	64172065001	8,730
<b>TX40</b>	100	64172070001	10,100
<b>TX45</b>	60	64172075001	8,730
<b>TX45</b>	100	64172080001	10,100
<b>TX50</b>	60	64172085001	8,730
<b>TX50</b>	100	64172090001	10,100
<b>TX55</b>	60	64172095001	8,730
<b>TX55</b>	100	64172100001	10,100



**SELPACK**  
1 pc.



# 64173 BUSSOLE CON INSERTO TXH

BUSSOLE 1/2" CON INSERTO PER VITI TORX® ANTI-MANOMISSIONE  
1/2" SOCKETS WITH BIT FOR TORX® TAMPER-RESISTANT SCREWS  
DOUILLES 1/2" AVEC EMBOUT POUR VIS TORX® DE SÉCURITÉ  
VASOS DE 1/2" CON PUNTA PARA TORNILLOS TORX® ANTIMANIPULACIÓN

40/44 HRC

EASYPACK | sacchetto PVC con Euro-hole • PVC bags with Euro-hole

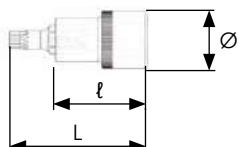

	L mm	l mm	Ø mm	PCS.	COD.	€ cad./each
<b>TXH10</b>	60	38	22	5	64173005	7,720
<b>TXH10</b>	100	38	22	5	64173010	9,000
<b>TXH15</b>	60	38	22	5	64173015	7,720
<b>TXH15</b>	100	38	22	5	64173020	9,000
<b>TXH20</b>	60	38	22	5	64173025	7,720
<b>TXH20</b>	100	38	22	5	64173030	9,000
<b>TXH25</b>	60	38	22	5	64173035	7,720
<b>TXH25</b>	100	38	22	5	64173040	9,000
<b>TXH27</b>	60	38	22	5	64173045	7,720
<b>TXH27</b>	100	38	22	5	64173050	9,000
<b>TXH30</b>	60	38	22	5	64173055	7,720
<b>TXH30</b>	100	38	22	5	64173060	9,000
<b>TXH40</b>	60	38	22	5	64173065	7,720
<b>TXH40</b>	100	38	22	5	64173070	9,000
<b>TXH45</b>	60	38	22	5	64173075	7,720
<b>TXH45</b>	100	38	22	5	64173080	9,000
<b>TXH50</b>	60	38	22	5	64173085	7,720
<b>TXH50</b>	100	38	22	5	64173090	9,000
<b>TXH55</b>	60	38	22	5	64173095	7,720
<b>TXH55</b>	100	38	22	5	64173100	9,000

	L mm	COD.	€ box
<b>TXH10</b>	60	64173005001	9,060
<b>TXH10</b>	100	64173010001	10,400
<b>TXH15</b>	60	64173015001	9,060
<b>TXH15</b>	100	64173020001	10,400
<b>TXH20</b>	60	64173025001	9,060
<b>TXH20</b>	100	64173030001	10,400
<b>TXH25</b>	60	64173035001	9,060
<b>TXH25</b>	100	64173040001	10,400
<b>TXH27</b>	60	64173045001	9,060
<b>TXH27</b>	100	64173050001	10,400
<b>TXH30</b>	60	64173055001	9,060
<b>TXH30</b>	100	64173060001	10,400
<b>TXH40</b>	60	64173065001	9,060
<b>TXH40</b>	100	64173070001	10,400
<b>TXH45</b>	60	64173075001	9,060
<b>TXH45</b>	100	64173080001	10,400
<b>TXH50</b>	60	64173085001	9,060
<b>TXH50</b>	100	64173090001	10,400
<b>TXH55</b>	60	64173095001	9,060
<b>TXH55</b>	100	64173100001	10,400



SELPACK  
1 pc.





# 3 BUSSOLE E ACCESSORI

SOCKETS AND ACCESSORIES  
DOUILLES ET ACCESSOIRES  
VASOS Y ACCESORIOS

**64175**

## BUSSOLE CON INSERTO RIBE

BUSSOLE 1/2" CON INSERTO RIBE®  
1/2" SOCKETS WITH RIBE® BIT  
DOUILLES 1/2" AVEC EMBOUT RIBE®  
VASOS DE 1/2" CON PUNTA RIBE®

40/44 HRC

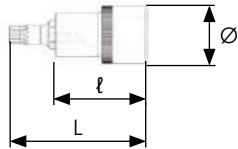

**EASYPACK** | sacchetto PVC con Euro-hole • PVC bags with Euro-hole

	L mm	l mm	Ø mm	PCS.	COD.	€ cad./each
<b>M4</b>	60	38	22	5	64175005	7,400
<b>M4</b>	100	38	22	5	64175010	8,680
<b>M5</b>	60	38	22	5	64175015	7,400
<b>M5</b>	100	38	22	5	64175020	8,680
<b>M6</b>	60	38	22	5	64175025	7,400
<b>M6</b>	100	38	22	5	64175030	8,680
<b>M7</b>	60	38	22	5	64175035	7,400
<b>M7</b>	100	38	22	5	64175040	8,680
<b>M8</b>	60	38	22	5	64175045	7,400
<b>M8</b>	100	38	22	5	64175050	8,680
<b>M9</b>	60	38	22	5	64175055	7,400
<b>M9</b>	100	38	22	5	64175060	8,680
<b>M10</b>	60	38	22	5	64175065	7,400
<b>M10</b>	100	38	22	5	64175070	8,680
<b>M12</b>	60	38	22	5	64175075	7,400
<b>M12</b>	100	38	22	5	64175080	8,680
<b>M14</b>	60	38	22	5	64175085	7,400
<b>M14</b>	100	38	22	5	64175090	8,680
<b>M16</b>	60	38	22	5	64175095	7,400
<b>M16</b>	100	38	22	5	64175100	8,680

	L mm	COD.	€ box
<b>M4</b>	60	64175005001	8,730
<b>M4</b>	100	64175010001	10,100
<b>M5</b>	60	64175015001	8,730
<b>M5</b>	100	64175020001	10,100
<b>M6</b>	60	64175025001	8,730
<b>M6</b>	100	64175030001	10,100
<b>M7</b>	60	64175035001	8,730
<b>M7</b>	100	64175040001	10,100
<b>M8</b>	60	64175045001	8,730
<b>M8</b>	100	64175050001	10,100
<b>M9</b>	60	64175055001	8,730
<b>M9</b>	100	64175060001	10,100
<b>M10</b>	60	64175065001	8,730
<b>M10</b>	100	64175070001	10,100
<b>M12</b>	60	64175075001	8,730
<b>M12</b>	100	64175080001	10,100
<b>M14</b>	60	64175085001	8,730
<b>M14</b>	100	64175090001	10,100
<b>M16</b>	60	64175095001	8,730
<b>M16</b>	100	64175100001	10,100



**SELPACK**  
1 pc.





# 64176 BUSSOLE CON INSERTO RIBE-H

BUSSOLE 1/2" CON INSERTO RIBE® CON FORO  
1/2" SOCKETS WITH RIBE® WITH HOLE BIT  
DOUILLES 1/2" AVEC EMBOUT RIBE® AVEC TROU  
VASOS DE 1/2" CON PUNTA RIBE® CON ORIFICIO

40/44 HRC

**EASYPACK** | sacchetto PVC con Euro-hole • PVC bags with Euro-hole

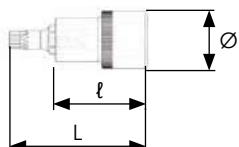

	L mm	l mm	Ø mm	PCS.	COD.	€ cad./each
<b>MH4</b>	60	38	22	5	64176005	7,720
<b>MH4</b>	100	38	22	5	64176010	9,000
<b>MH5</b>	60	38	22	5	64176015	7,720
<b>MH5</b>	100	38	22	5	64176020	9,000
<b>MH6</b>	60	38	22	5	64176025	7,720
<b>MH6</b>	100	38	22	5	64176030	9,000
<b>MH7</b>	60	38	22	5	64176035	7,720
<b>MH7</b>	100	38	22	5	64176040	9,000
<b>MH8</b>	60	38	22	5	64176045	7,720
<b>MH8</b>	100	38	22	5	64176050	9,000
<b>MH9</b>	60	38	22	5	64176055	7,720
<b>MH9</b>	100	38	22	5	64176060	9,000
<b>MH10</b>	60	38	22	5	64176065	7,720
<b>MH10</b>	100	38	22	5	64176070	9,000
<b>MH12</b>	60	38	22	5	64176075	7,720
<b>MH12</b>	100	38	22	5	64176080	9,000

	L mm	COD.	€ box
<b>MH4</b>	60	64176005001	9,060
<b>MH4</b>	100	64176010001	10,400
<b>MH5</b>	60	64176015001	9,060
<b>MH5</b>	100	64176020001	10,400
<b>MH6</b>	60	64176025001	9,060
<b>MH6</b>	100	64176030001	10,400
<b>MH7</b>	60	64176035001	9,060
<b>MH7</b>	100	64176040001	10,400
<b>MH8</b>	60	64176045001	9,060
<b>MH8</b>	100	64176050001	10,400
<b>MH9</b>	60	64176055001	9,060
<b>MH9</b>	100	64176060001	10,400
<b>MH10</b>	60	64176065001	9,060
<b>MH10</b>	100	64176070001	10,400
<b>MH12</b>	60	64176075001	9,060
<b>MH12</b>	100	64176080001	10,400



**SELPACK**  
1 pc.





# 3 BUSSOLE E ACCESSORI

SOCKETS AND ACCESSORIES  
DOUILLES ET ACCESSOIRES  
VASOS Y ACCESORIOS

**64174**

**BUSSOLE CON INSERTO XZN**

BUSSOLE 1/2" CON INSERTO XZN  
1/2" SOCKETS WITH XZN BIT  
DOUILLES 1/2" AVEC EMBOUT XZN  
VASOS DE 1/2" CON PUNTA XZN

40/44 HRC

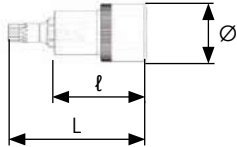

**EASYPACK** | sacchetto PVC con Euro-hole • PVC bags with Euro-hole

	L mm	l mm	Ø mm	PCS.	COD.	€ cad./each
<b>M5</b>	60	38	22	5	64174005	7,720
<b>M5</b>	100	38	22	5	64174010	9,000
<b>M6</b>	60	38	22	5	64174015	7,720
<b>M6</b>	100	38	22	5	64174020	9,000
<b>M8</b>	60	38	22	5	64174025	7,720
<b>M8</b>	100	38	22	5	64174030	9,000
<b>M10</b>	60	38	22	5	64174035	7,720
<b>M10</b>	100	38	22	5	64174040	9,000
<b>M12</b>	60	38	22	5	64174045	7,720
<b>M12</b>	100	38	22	5	64174050	9,000
<b>M14</b>	60	38	22	5	64174055	7,720
<b>M14</b>	100	38	22	5	64174060	9,000
<b>M16</b>	55	38	22	5	64174066	11,300
<b>M18</b>	55	38	22	5	64174075	13,700
<b>M20</b>	55	38	22	5	64174085	18,500

	L mm	COD.	€ box
<b>M5</b>	60	64174005001	9,060
<b>M5</b>	100	64174010001	10,400
<b>M6</b>	60	64174015001	9,060
<b>M6</b>	100	64174020001	10,400
<b>M8</b>	60	64174025001	9,060
<b>M8</b>	100	64174030001	10,400
<b>M10</b>	60	64174035001	9,060
<b>M10</b>	100	64174040001	10,400
<b>M12</b>	60	64174045001	9,060
<b>M12</b>	100	64174050001	10,400
<b>M14</b>	60	64174055001	9,060
<b>M14</b>	100	64174060001	10,400
<b>M16</b>	55	64174066001	12,600
<b>M18</b>	55	64174075001	15,000
<b>M20</b>	55	64174085001	19,900



**SELPACK**  
1 pc.



**64177**

# ASSORTIMENTI BUSSOLE 1/2" CON INSERTO TX E TXH

ASSORTIMENTI BUSSOLE 1/2" CON INSERTO  
1/2" SOCKETS SETS WITH BIT  
JEU DOUILLES 1/2" AVEC EMBOUT  
JUEGO DE VASOS DE 1/2" CON PUNTA





8 pcs.

200 X 46 X 13 mm

COD. **64177001**

€ 46,200

64172x60mm  

TX20	TX25	TX27	TX30	TX40	TX45	TX50	TX55
1pc.	1pc.	1pc.	1pc.	1pc.	1pc.	1pc.	1pc.

COD. **64177002**

€ 54,600

64172x100mm  

TX20	TX25	TX27	TX30	TX40	TX45	TX50	TX55
1pc.	1pc.	1pc.	1pc.	1pc.	1pc.	1pc.	1pc.

COD. **64177005**

€ 50,100

64173x60mm  

TXH20	TXH25	TXH27	TXH30	TXH40	TXH45	TXH50	TXH55
1pc.	1pc.	1pc.	1pc.	1pc.	1pc.	1pc.	1pc.

COD. **64177006**

€ 58,500

64173x100mm  

TXH20	TXH25	TXH27	TXH30	TXH40	TXH45	TXH50	TXH55
1pc.	1pc.	1pc.	1pc.	1pc.	1pc.	1pc.	1pc.

3





# 3 BUSSOLE E ACCESSORI

SOCKETS AND ACCESSORIES  
DOUILLES ET ACCESSOIRES  
VASOS Y ACCESORIOS

## 64177 ASSORTIMENTI BUSSOLE 1/2" CON INSERTO RIBE E RIBE-H

ASSORTIMENTI BUSSOLE 1/2" CON INSERTO  
1/2" SOCKETS SETS WITH BIT  
JEU DOUILLES 1/2" AVEC EMBOUT  
JUEGO DE VASOS DE 1/2" CON PUNTA



8  
pcs.

200 X 46 X 13 mm

COD. **64177011**

€ 48,300

64175x60mm

M6	M7	M8	M9	M10	M12	M14	M16
1pc.	1pc.	1pc.	1pc.	1pc.	1pc.	1pc.	1pc.

COD. **64177012**

€ 58,200

64175x100mm

M6	M7	M8	M9	M10	M12	M14	M16
1pc.	1pc.	1pc.	1pc.	1pc.	1pc.	1pc.	1pc.

COD. **64177015**

€ 45,400



6  
pcs.

200 X 46 X 13 mm

64176x60mm

MH6	MH7	MH8	MH9	MH10	MH12
1pc.	1pc.	1pc.	1pc.	1pc.	1pc.

COD. **64177016**

€ 50,400

64176x100mm

MH6	MH7	MH8	MH9	MH10	MH12
1pc.	1pc.	1pc.	1pc.	1pc.	1pc.



**64177**

## ASSORTIMENTI BUSSOLE 1/2" CON INSERTO ESAGONALE E XZN

ASSORTIMENTI  
BUSSOLE 1/2" CON INSERTO  
1/2" SOCKETS SETS WITH BIT  
JEU DOUILLES 1/2" AVEC EMBOUT  
JUEGO DE VASOS DE 1/2" CON PUNTA



8  
pcs.

200 X 46 X 13 mm

COD. **64177021**

€ 47,200

64171x60mm

4 1pc.	5 1pc.	6 1pc.	7 1pc.	8 1pc.	10 1pc.	12 1pc.	14 1pc.
-----------	-----------	-----------	-----------	-----------	------------	------------	------------

COD. **64177022**

€ 55,800

64171x100mm

4 1pc.	5 1pc.	6 1pc.	7 1pc.	8 1pc.	10 1pc.	12 1pc.	14 1pc.
-----------	-----------	-----------	-----------	-----------	------------	------------	------------

COD. **64177025**

€ 45,400



6  
pcs.

200 X 46 X 13 mm

64174x60mm

M5 1pc.	M6 1pc.	M8 1pc.	M10 1pc.	M12 1pc.	M14 1pc.
------------	------------	------------	-------------	-------------	-------------

COD. **64177026**

€ 43,500

64174x100mm

M5 1pc.	M6 1pc.	M8 1pc.	M10 1pc.	M12 1pc.	M14 1pc.
------------	------------	------------	-------------	-------------	-------------

3





# 3 BUSSOLE E ACCESSORI

SOCKETS AND ACCESSORIES  
DOUILLES ET ACCESSOIRES  
VASOS Y ACCESORIOS

## 62195 PROLUNGHE CON SFERA

PROLUNGA PER BUSSOLE 1/2"  
EXTENSION FOR 1/2" SOCKETS  
RALLONGE POUR DOUILLES 1/2"  
EXTENSION PARA VASOS DE 1/2"

40/44 HRC

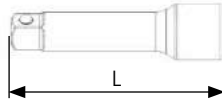
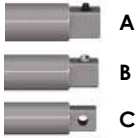

**EASYPACK** | sacchetto PVC con Euro-hole • PVC bags with Euro-hole

L mm	A/B/C	Ø mm	PCS.	COD.	€ cad./each
50	B	22	5	62195005	6,430
125	B	22	5	62195010	11,400
150	B	22	5	62195015	12,800
250	B	22	5	62195020	15,600



**SELPACK**  
1 pc.

L mm	COD.	€ box
50	62195005001	7,770
125	62195010001	12,800
150	62195015001	14,100
250	62195020001	16,900

## 62196 PROLUNGHE SNODATE

PROLUNGA PER BUSSOLE 1/2" SNODATA  
UNIVERSAL JOINT FOR 1/2" SOCKETS  
RALLONGE POUR DOUILLES 1/2" ARTICULÉE  
EXTENSION PARA VASOS DE 1/2" CON ARTICULACIÓN

40/44 HRC

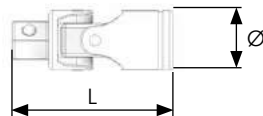
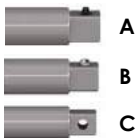

**EASYPACK** | sacchetto PVC con Euro-hole • PVC bags with Euro-hole

L mm	A/B/C	Ø mm	PCS.	COD.	€ cad./each
73	B	22	1	62196005	11,300



**SELPACK**  
1 pc.

L mm	COD.	€ box
73	62196005001	12,600



## 62116 RIDUZIONI PER BUSSOLE 3/8"

RIDUZIONE 1/2" PER BUSSOLE DA 3/8"  
1/2" REDUCTION FOR 3/8" SOCKETS  
RÉDUCTION 1/2" POUR DOUILLES DE 3/8"  
REDUCTOR DE 1/2" PARA VASOS DE 3/8"

40/44 HRC

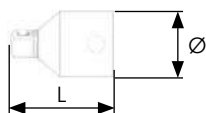
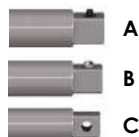

**EASYPACK** | sacchetto PVC con Euro-hole • PVC bags with Euro-hole

L mm	A/B/C	Ø mm	PCS.	COD.	€ cad./each
36	B	22	1	62116001	4,220



**SELPACK**  
1 pc.

L mm	COD.	€ box
36	62116001001	5,560

## 62135 ADATTATORI PER BUSSOLE 3/4"

ADATTATORE/AUMENTATORE 1/2" PER BUSSOLE DA 3/4"  
1/2" ADAPTER/ENHANCER FOR 3/4" SOCKETS  
ADAPTATEUR/AUGMENTATEUR 1/2" POUR DOUILLES DE 3/4"  
ADAPTADOR/EXTENSOR DE 1/2" PARA VASOS DE 3/4"

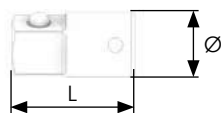
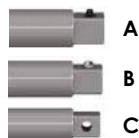

**EASYPACK** | sacchetto PVC con Euro-hole • PVC bags with Euro-hole

L mm	A/B/C	Ø mm	PCS.	COD.	€ cad./each
47	B	26	1	62135001	7,640



**SELPACK**  
1 pc.

L mm	COD.	€ box
47	62135001001	8,980





# 3 BUSSOLE E ACCESSORI

SOCKETS AND ACCESSORIES  
DOUILLES ET ACCESSOIRES  
VASOS Y ACCESORIOS

## 64224 BARRE A "T"

LEVA PER BUSSOLE CON ASTA MOBILE  
LEVER FOR SOCKETS WITH MOBILE ROD  
LEVIER POUR DOUILLE AVEC TIGE MOBILE  
PALANCA PARA VASOS CON VARILLA MÓVIL

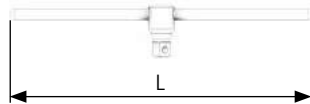
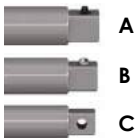

L mm	A/B/C	PCS.	COD.	€ cad./each
300	B	1	64224001	14,500



SELFPACK  
1 pc.

L mm	COD.	€ box
300	64224001001	15,800

## 64224 CRICCHETTI REVERSIBILI 72 DENTI

CRICCHETTO REVERSIBILE 72T  
72 REVERSIBLE RATCHET  
CLIQUET RÉVERSIBLE 72T  
CARRACA REVERSIBLE 72T

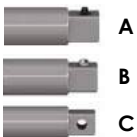

L mm	A/B/C	PCS.	COD.	€ cad./each
250	B	1	64224005	40,200



## 64224 CRICCHETTI REVERSIBILI 45 DENTI

CRICCHETTO REVERSIBILE 45T  
45T REVERSIBLE RATCHET  
CLIQUET RÉVERSIBLE 45T  
CARRACA REVERSIBLE 45T

**NEW!**

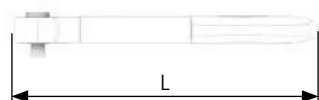
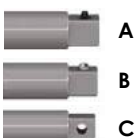

L mm	A/B/C	PCS.	COD.	€ cad./each
255	B	1	64224006	22,000







## 64224 CRICCHETTI ONE-TOUCH

CRICCHETTO REVERSIBILE SISTEMA ONE-TOUCH  
REVERSIBLE RATCHET ONE-TOUCH SYSTEM  
CLIQUET RÉVERSIBLE SYSTÈME ONE-TOUCH  
CARRACA REVERSIBLE CON SISTEMA ONE-TOUCH

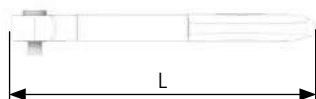
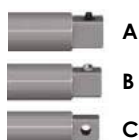

L mm	A/B/C	PCS.	COD.	€ cad./each
245	B	1	64224010	50,000



### FOCUS ON



Movimento a 60 denti, ghiera di inversione della rotazione direttamente sul manico.  
Movement with 60 teeth, reversal of the rotation of the ring nut directly on the handle.  
Mouvement à 60 dents, bague d'inversion de la rotation directement sur la poignée.  
Movimiento de 60 dientes, abrazadera de inversión de la rotación directamente sobre el mango.



## 64224 CRICCHETTI TELESCOPICI

CRICCHETTO REVERSIBILE CON ASTA TELESCOPICA  
REVERSIBLE RATCHET WITH TELESCOPIC ROD  
CLIQUET RÉVERSIBLE AVEC TIGE TÉLESCOPIQUE  
CARRACA REVERSIBLE CON ASTA TELESCÓPICA

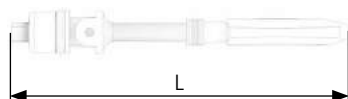
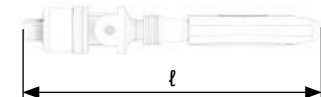
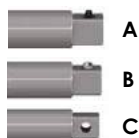

L mm	ℓ mm	A/B/C	PCS.	COD.	€ cad./each
508	368	B	1	64224015	46,800

3



### FOCUS ON



Movimento a 36 denti, testa snodata ad alta resistenza, braccio telescopico.  
Movement with 36 teeth, high-resistance jointed head, telescopic arm.  
Mouvement à 36 dents, tête articulée haute résistance, bras télescopique.  
Movimiento de 36 dientes, cabeza articulada de alta resistencia, brazo telescópico.





# 3 BUSSOLE E ACCESSORI

SOCKETS AND ACCESSORIES  
DOUILLES ET ACCESSOIRES  
VASOS Y ACCESORIOS

**62602**

SET RIDUZIONI-ADATTATORI

ASSORTIMENTO 6 PCS. RIDUZIONI / ADATTATORI  
6PCS. REDUCTIONS / ADAPTERS SET  
JEU 6 PCS. RÉDUCTIONS / ADAPTATEURS  
JUEGO DE 6 PCS. REDUCTORES / ADAPTADORES



130 X 50 X 100 mm

6  
pcs.

COD. **62602001**

€ 26,200

$\frac{1}{4}$ $\frac{3}{8}$	$\frac{3}{8}$ $\frac{1}{2}$	$\frac{1}{2}$ $\frac{3}{4}$	$\frac{3}{8}$ $\frac{1}{4}$	$\frac{1}{2}$ $\frac{3}{8}$	$\frac{3}{4}$ $\frac{1}{2}$
1pc.	1pc.	1pc.	1pc.	1pc.	1pc.



# 64300 SET BUSSOLE ED ACCESSORI

ASSORTIMENTI 14 PCS. BUSSOLE ED ACCESSORI CON CRICCHETTO  
 14 PCS. SOCKETS AND ACCESSORIES SET WITH RATCHET  
 JEU 14 PIÈCES DOUILLES ET ACCESSOIRES AVEC CLIQUET  
 JUEGO DE 14 PIEZAS VASOS Y ACCESORIOS CON CARRACA



14 pcs.

COD. **64300001**  
 € 29,000



4	5	6	7	8	9	10	11	12	13	14
1pc.	1pc.	1pc.	1pc.	1pc.	1pc.	1pc.	1pc.	1pc.	1pc.	1pc.

INCLUSO / INCLUDED / INCLUSE / INCLUIDO 120 X 330 X 45 mm



COD. **64300010**  
 € 39,000



8	9	10	11	12	13	14	15	16	17	19
1pc.	1pc.	1pc.	1pc.	1pc.	1pc.	1pc.	1pc.	1pc.	1pc.	1pc.

INCLUSO / INCLUDED / INCLUSE / INCLUIDO 120 X 330 X 45 mm



COD. **64300020**  
 € 49,000



10	11	12	13	14	17	19	21	22	24
1pc.	1pc.	1pc.	1pc.	1pc.	1pc.	1pc.	1pc.	1pc.	1pc.

INCLUSO / INCLUDED / INCLUSE / INCLUIDO 140 X 39 X 55 mm



13 pcs.





# 64230 SET BUSSOLE, ACCESSORI E INSERTI 1/4"

ASSORTIMENTO 39 PCS. BUSSOLE ED ACCESSORI 1/4" IN VALIGETTA METALLICA  
 39 PCS. SOCKETS AND 1/4" ACCESSORIES SET IN METAL CASE  
 JEU 39 PIÈCES DOUILLES ET ACCESSOIRES 1/4" DANS VALISE MÉTALL  
 JUEGO DE 39 PIEZAS VASOS Y ACCESORIOS DE 1/4" EN MALETÍN METÁLICO



39 pcs.

245 X 35 X 120 mm



COD. **64230005**

€ 68,000

64150		64151		64149		
PH1 1pc.	PH2 1pc.	PZ1 1pc.	PZ2 1pc.	0,6x4,0 1pc.	0,8x5,5 1pc.	1,2x7,0 1pc.

64147						
TX10 1pc.	TX15 1pc.	TX20 1pc.	TX25 1pc.	TX27 1pc.	TX30 1pc.	TX40 1pc.

64145					
3 1pc.	4 1pc.	5 1pc.	6 1pc.	7 1pc.	8 1pc.

64008													
4 1pc.	4,5 1pc.	5 1pc.	5,5 1pc.	6 1pc.	7 1pc.	8 1pc.	9 1pc.	10 1pc.	11 1pc.	12 1pc.	13 1pc.	14 1pc.	

INCLUSO / INCLUDED / INCLUSE / INCLUIDO

COD. 62173005				50mm
COD. 62173010				150mm
COD. 62174005				
COD. 64220005				
COD. 64221005				
COD. 65999002				



# 3 BUSSOLE E ACCESSORI

SOCKETS AND ACCESSORIES  
DOUILLES ET ACCESSOIRES  
VASOS Y ACCESORIOS

**64230**

SET BUSSOLE, ACCESSORI  
E INSERTI 1/4"

ASSORTIMENTO 46 PCS BUSSOLE ED ACCESSORI 1/4" VALIGETTA IN TERMOFORMATO  
46 PCS 1/4" SOCKETS AND ACCESSORIES SET IN BLOW MOLD CASE  
JEU 46 PCS DOUILLES ET ACCESSOIRES 1/4" DANS VALISE DE MOULE DE SOUFFLE  
JUEGO DE 46 PCS VASOS Y ACCESORIOS DE 1/4" EN MALETIN DE MOLDE

**NEW!**

46  
pcs.



250 X 170 X 50 mm

COD. **64230008**

€ 42,000

64150

PH1  
1pc.

64151

PH2  
1pc.

64149

PH3  
1pc.

PZ1  
1pc.

PZ2  
1pc.

PZ3  
1pc.

4  
1pc.

5,5  
1pc.

7  
1pc.

64147

TX10  
1pc.

TX15  
1pc.

TX20  
1pc.

TX25  
1pc.

TX30  
1pc.

TX40  
1pc.

64145

3  
1pc.

4  
1pc.

5  
1pc.

6  
1pc.

7  
1pc.

8  
1pc.

64008

4 1pc. 4,5 1pc. 5 1pc. 5,5 1pc. 6 1pc. 7 1pc. 8 1pc. 9 1pc. 10 1pc. 11 1pc. 12 1pc. 13 1pc. 14 1pc.



INCLUSO / INCLUDED / INCLUDE / INCLUIDO

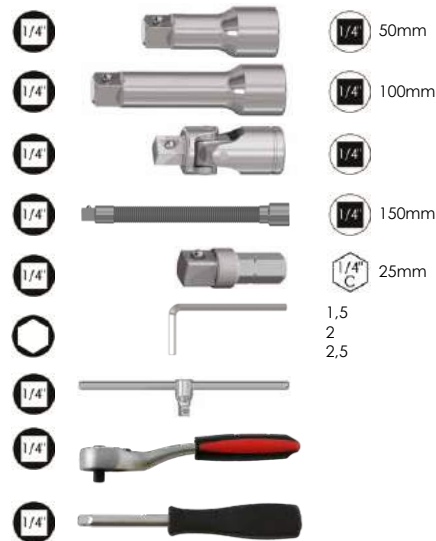



# 64230 SET BUSSOLE, ACCESSORI 1/4" CON CHIAVI COMBinate

ASSORTIMENTO 40 PCS BUSSOLE ED ACCESSORI 1/4" CON CHIAVI COMBinate  
 40 PCS 1/4" SOCKETS AND ACCESSORIES SET WITH COMBINATION WRENCHES  
 JEU 40 PCS DOUILLES ET ACCESSOIRES 1/4" AVEC CLÉS MIXTES  
 JUEGO DE 40 PCS VASOS Y ACCESORIOS DE 1/4" CON LLAVES COMBINADAS

**NEW!**

40 pcs.

COD. **64230009**

€ 47,200



245 X 35 X 120 mm

		4,0	5,5	6,0	7,0				
		PH1	PH2	PH3					
		TX10	TX15	TX20	TX25	TX30	TX40		
		4	5	6	8				
		4	4,5	5	5,5	6	7	8	
		9	10	11	12	13	14		
				50			7	8	10
								13	17





# 3 BUSSOLE E ACCESSORI

SOCKETS AND ACCESSORIES  
DOUILLES ET ACCESSOIRES  
VASOS Y ACCESORIOS

**64230**

SET BUSSOLE, ACCESSORI  
E INSERTI 3/8"

ASSORTIMENTO 30 PCS. BUSSOLE ED ACCESSORI 3/8" IN VALIGETTA METALLICA  
30 PCS. SOCKETS AND 3/8" ACCESSORIES SET IN METAL CASE  
JEU 30 PIÈCES DOUILLES ET ACCESSOIRES 3/8" DANS VALISE MÉTALL  
JUEGO DE 30 PIEZAS VASOS Y ACCESORIOS DE 3/8" EN MALETÍN METÁLICO

COD. **64230010**

€ 92,000



30  
pcs.

315 X 45 X 140 mm



64163

64161

T20	T25	T27	T30	T40	T45	T50	3	4	5	6	8	10
1pc.	1pc.	1pc.	1pc.	1pc.	1pc.	1pc.	1pc.	1pc.	1pc.	1pc.	1pc.	1pc.

64026

7	8	10	11	12	13	14	15	17	19	21	22	24
1pc.	1pc.	1pc.	1pc.	1pc.	1pc.	1pc.	1pc.	1pc.	1pc.	1pc.	1pc.	1pc.

INCLUSO / INCLUDED / INCLUSE / INCLUIDO

COD. 62185005 3/8" 45mm

COD. 62185010 3/8" 150mm

COD. 62186005 3/8" 3/8"

COD. 64223005





# 64230 SET BUSSOLE, ACCESSORI 3/8"

ASSORTIMENTO 26 PCS BUSSOLE ED ACCESSORI 3/8" VALIGETTA IN TERMOFORMATO  
 26 PCS 3/8" SOCKETS AND ACCESSORIES SET IN BLOW MOLD CASE  
 JEU 26 PCS DOUILLES ET ACCESSOIRES 3/8" DANS VALISE DE MOULE DE SOUFFLE  
 JUEGO DE 26 PCS VASOS Y ACCESORIOS DE 3/8" EN MALETIN DE MOLDE

**NEW!**

26  
pcs.

COD. **64230013**

€ 47,800



345 X 85 X 260 mm

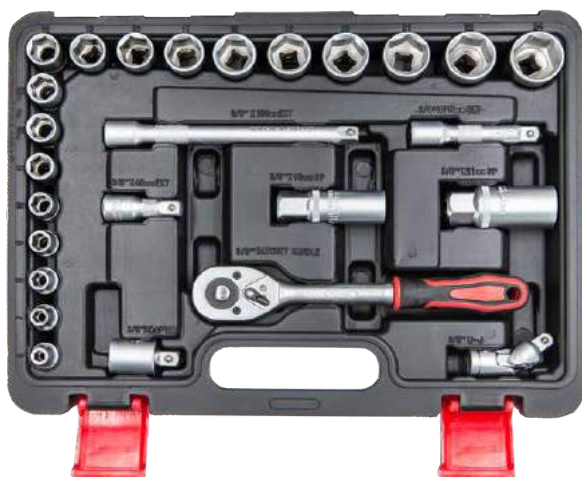

6	7	8	9	10	11	12	13	14
1pc.	1pc.	1pc.	1pc.	1pc.	1pc.	1pc.	1pc.	1pc.
15	16	17	18	19	20	21	22	24
1pc.	1pc.	1pc.	1pc.	1pc.	1pc.	1pc.	1pc.	1pc.

INCLUSO / INCLUDED / INCLUSE / INCLUIDO

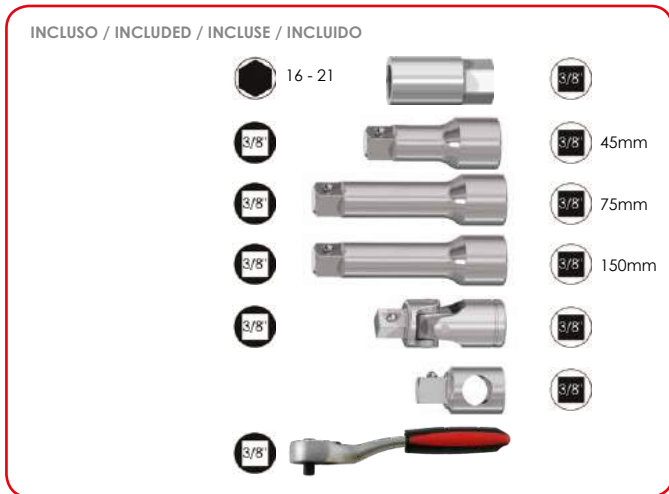



# 3 BUSSOLE E ACCESSORI

SOCKETS AND ACCESSORIES  
DOUILLES ET ACCESSOIRES  
VASOS Y ACCESORIOS

## 64230 SET BUSSOLE E ACCESSORI 1/2"

ASSORTIMENTO 23 PCS. BUSSOLE ED ACCESSORI 1/2" IN VALIGETTA METALLICA  
23 PCS. SOCKETS AND 1/2" ACCESSORIES SET IN METAL CASE  
JEU 23 PIÈCES DOUILLES ET ACCESSOIRES 1/2" DANS VALISE MÉTALL  
JUEGO DE 23 PIEZAS VASOS Y ACCESORIOS DE 1/2" EN MALETÍN METÁLICO



23  
pcs.

COD. **64230015**

€ 116,000

64048

10 1pc.	11 1pc.	12 1pc.	13 1pc.	14 1pc.	15 1pc.	16 1pc.	17 1pc.	18 1pc.
19 1pc.	20 1pc.	21 1pc.	22 1pc.	23 1pc.	24 1pc.	27 1pc.	30 1pc.	32 1pc.

445 X 50 X 190 mm



INCLUSO / INCLUDED / INCLUSE / INCLUIDO

COD. 62195005				50mm
COD. 62195010				125mm
COD. 62195015				150mm
COD. 62196005				
COD. 64224005				



**64230** SET BUSSOLE, ACCESSORI 1/2"

ASSORTIMENTO 32 PCS BUSSOLE ED ACCESSORI 1/2" VALIGETTA IN TERMOFORMATO  
 32 PCS 1/2" SOCKETS AND ACCESSORIES SET IN BLOW MOLD CASE  
 JEU 32 PCS DOUILLES ET ACCESSOIRES 1/2" DANS VALISE DE MOULE DE SOUFFLE  
 JUEGO DE 32 PCS VASOS Y ACCESORIOS DE 1/2" EN MALETIN DE MOLDE

**NEW!**

32  
pcs.

COD. **64230018**  
€ 78,700



345 X 85 X 260 mm



8	9	10	11	12	13	14	15	16	17
1pc.	1pc.	1pc.	1pc.	1pc.	1pc.	1pc.	1pc.	1pc.	1pc.
18	19	20	21	22	24	27	30	32	
1pc.	1pc.	1pc.	1pc.	1pc.	1pc.	1pc.	1pc.	1pc.	
10	12	14	15	17	19				
1pc.	1pc.	1pc.	1pc.	1pc.	1pc.				

INCLUSO / INCLUDED / INCLUSE / INCLUIDO





# 3 BUSSOLE E ACCESSORI

SOCKETS AND ACCESSORIES  
DOUILLES ET ACCESSOIRES  
VASOS Y ACCESORIOS

**64230**

**SET BUSSOLE E ACCESSORI 3/4"**

ASSORTIMENTO 20 PCS. BUSSOLE ED ACCESSORI 3/4" IN VALIGETTA METALLICA  
20 PCS. SOCKETS AND 3/4" ACCESSORIES SET IN METAL CASE  
JEU 20 PIÈCES DOUILLES ET ACCESSOIRES 3/4" DANS VALISE MÉTALL.  
JUEGO DE 20 PIEZAS VASOS Y ACCESORIOS DE 3/4" EN MALETÍN METÁLICO

20  
pcs.

COD. **64230020**

€ 301,000



540 X 80 X 180 mm



3/4"

19 1pc.	21 1pc.	22 1pc.	23 1pc.	24 1pc.	26 1pc.	27 1pc.	29 1pc.
30 1pc.	32 1pc.	35 1pc.	36 1pc.	38 1pc.	41 1pc.	46 1pc.	50 1pc.

INCLUSO / INCLUDED / INCLUSE / INCLUIDO





**64230**

**SET BUSSOLE  
E ACCESSORI 1/4" E 1/2"**

ASSORTIMENTO 82 PCS. BUSSOLE ED ACCESSORI 1/4" E 1/2" CON CHIAVI A CRICCHETTO  
82 SOCKETS AND ACCESSORIES 1/4" AND 1/2" SET WITH RATCHET WRENCHES  
JEU 82 PIÈCES DOUILLES ET ACCESSOIRES 1/4" ET 1/2" AVEC CLÉS À CLIQUET  
JUEGO 82 PIEZAS VASOS Y ACCESORIOS DE 1/4", 1/2" Y LLAVES COMBINADAS DE CARRACA

**NEW!**

82  
pcs.



390 X 90 X 290 mm



cricchetto  
ratchet

COD. **64230024**

€ 158,000

	8,0	10,0	12,0							
	PH3	PH4								
	PZ3	PZ4								
	TX30	TX40	TX45	TX50						
	7	8	10	12						
	4,0	5,0	7,0							
	PH1	PH2								
	PZ1	PZ2								
	TX8	TX10	TX15	TX20	TX25	TX30				
	3	4	5	6						
	4	4,5	5	5,5	6	7	8			
	9	10	11	12	13	14				
	14	15	16	17	18	19	20			
	22	24	27	30	32					
		8	10	11	12	13	14	17	19	22
			40				50	100		
			73				125	250		
							16			
							21			



# 3 BUSSOLE E ACCESSORI

SOCKETS AND ACCESSORIES  
DOUILLES ET ACCESSOIRES  
VASOS Y ACCESORIOS

## 64230 SET BUSSOLE, ACCESSORI E INSERTI 1/4" - 1/2"

ASSORTIMENTO 108 PCS. BUSSOLE ED ACCESSORI 1/4" E 1/2" IN VALIGETTA ANTI-URTO  
108 SOCKETS AND ACCESSORIES 1/4" AND 1/2" SET IN SHOCK-PROOF CASE  
JEU 108 PIÈCES DOUILLES ET ACCESSOIRES 1/4" ET 1/2" DANS VALISE MÉTALL.  
JUEGO DE 108 PIEZAS VASOS Y ACCESORIOS DE 1/4" Y DE 1/2" EN MALETÍN ANTI-CHOQUE

**NEW!**

108 pcs.



380 X 80 X 290 mm



COD. **64230030**

€ 131,200

	4	5,5	6,5				
	PH1	PH2					
	PZ1	PZ2					
	TX8	TX10	TX15	TX20	TX25	TX27	TX30
	3	4	5	6			
	8	10	12				
	PH2	PH3					
	PZ2	PZ3					
	TX40	TX45	TX50	TX55	TX60		
	6	8	10	12	14		
	4	4,5	5	5,5	6	7	
	8	9	10	11	12	13	
	14						
	10	11	12	13	14	15	
	16	17	18	19	20	21	
	22	24	27	30	32		
	6	7	8	9	10	11	
	12	13					
	14	15	17	19	22		
	candele / spark plug					16	21
	E4	E5	E6	E7	E8		
	E10	E11	E12	E14	E16	E18	
	E20	E24					
	50	100					
	125	250					
						1,5	
						2	
						2,5	



**64230**

**SET BUSSOLE, ACCESSORI  
E INSERTI 1/4" - 3/8" - 1/2"**

ASSORTIMENTO 215 PCS. BUSSOLE ED ACCESSORI 1/4"-3/8"-1/2" CON CHIAVI A CRICCHETTO  
215 SOCKETS AND ACCESSORIES 1/4"-3/8"-1/2" SET WITH RATCHET WRENCHES  
JEU 215 PIÈCES DOUILLES ET ACCESSOIRES 1/4"-3/8"-1/2" AVEC CLÉS À CLIQUET  
JUEGO 215 PIEZAS VASOS Y ACCESORIOS DE 1/4"-3/8"-1/2" Y LLAVES COMBINADAS DE CARRACA

**NEW!**



450 X 90 X 350 mm



cricchetto  
ratchet



215  
pcs.

COD. **64230045**

€ 260,000

	4,0	5,5	6,5	7,0				
	PH1	PH1	PH2	PH3				
	PZ1	PZ1	PZ2	PZ3				
	THX8	THX10	THX15	THX20	THX25	THX27	THX30	
	THX40	THX45						
	2	2,5	3	4	5	6	7	
	1	2	3	4				
	6	8	10					
	5	6	8	10	12			
	4	6	8	10				
	6,0	6,5	8,0					
	PH3	PH4						
	PZ3	PZ4						
	TX27	TX30	TX35	TX40	TX45	TX50		
	TXH27	TXH30	TXH35	TXH40	TXH45	TXH50		
	5,5	6	6,5	7	8	10	12	
	5	6	8	10				
	4,0	5,5	6,5	7,0				
	PH0	PH1	PH2					
	PZ0	PZ1	PZ2					
	TX8	TX9	TX10	TX15	TX20	TX25	TX27	
	TX30							
	TXH8	TXH9	TXH10	TXH15	TXH20	TXH25	TXH27	
	TXH30							
	3	4	5	6				
	TX55		16					
	TX60		21 x 2pcs					
	4	4,5	5	5,5	6	7	8	
	9	10	11	12	13	14		
	10	11	12	13	14	15	16	
	17	18	19					
	13	14	15	16	17	18	19	
	20	21	22	24	27	30	32	
	4	5	6	7	8	9	10	
	10	11	12	13	14	15		
	16	17	18	19	22			
	E4	E5	E6	E7	E8			
	E10	E11	E12	E14	E16	E18		
	E22	E22	E24					
	1,5	2	2,5	3	4	5		



# 3 BUSSOLE E ACCESSORI

SOCKETS AND ACCESSORIES  
DOUILLES ET ACCESSOIRES  
VASOS Y ACCESORIOS

**64230** VALIGETTA IN ABS ANTIURTO

VALIGETTA 153 PCS. UTENSILI ASSORTITI PER PROFESSIONISTI  
CASE WITH 153 ASSORTED TOOLS FOR PROFESSIONALS  
VALISE DE 153 PIÈCES JEU D'OUTILS POUR LES PROFESSIONNELS  
SURTIDO 153 PIEZAS DE UTENSILIOS PARA PROFESIONALES

**NEW!**



153 pcs.

**SPECIALE PER MANUTENZIONE**  
**SPECIAL FOR MAINTENANCE**



470 X 150 X 360 mm







**FOCUS ON**



**GUSCIO ABS  
ANTIURTO**

Valigetta con quattro vassoi interni, assortimento completo bussole ed accessori 1/4" e 1/2", inserti 5/16" con le impronte più indicate per il settore meccanico.

Case with four internal trays, complete assortment of bearings and accessories 1/4" and 1/2", 5/16" inserts with the most suitable imprints for the mechanical sector.

Malette avec quatre plateaux internes, assortiment complet de bagues et d'accessoires 1/4 "et 1/2", embouts 5/16 "avec les marques les plus appropriées pour le secteur mécanique.

Maletín con cuatro bandejas internas, surtido completo de casquillos y accesorios de 1/4 "y 1/2", 5/16" con las huellas más adecuadas para el sector mecánico.



COD. **64230303**

€ 346,000

	4	4,5	5	5,5	6	7		
	8	9	10	11	12	13		
	10	13	14	15	16	17	18	
	19	20	22	24	27	30	32	
	8	10	11	12	13	14	15	17
								22
	1,5	2	2,5				10	15
	3	4	5				25	27
	6	8	10				40	45
								50
	0,6x3,5	1x5,5	1,2x6,5					
	PH1	PH2						
	PZ2						50	100
							125	250
	8	10						
	PH3	PH4						
	TXH40	TXH45	TXH50	TXH55				
	10	12	14					

		3,0	4,0	5,0	2pcs. 6,0	7,0		
		PH0	2pcs. PH1	2pcs. PH2	PH3			
		PZ0	2pcs. PZ1	2pcs. PZ2	PZ3			
		TX10	TX15	TX20	TX25	TX27	TX30	
		2,5	3	4	5	5,5	6	
	LED							TESTER 250V
	180mm							180mm
	200mm							140mm
	160mm							180mm
	250mm							300mm
	240mm							2 pcs
	150mm							300gr
	5m							310mm
	600mm							20 pcs

3



# 3 BUSSOLE E ACCESSORI

SOCKETS AND ACCESSORIES  
DOUILLES ET ACCESSOIRES  
VASOS Y ACCESORIOS

64230

VALIGETTA UTENSILI MANUALI  
CON BUSSOLE E ACCESSORI 1/4" 1/2" 3/8"

TROLLEY 179 PCS. UTENSILI ASSORTITI PER PROFESSIONISTI  
TROLLEY WITH 179 ASSORTED TOOLS FOR PROFESSIONALS  
TROLLEY DE 179 PIÈCES JEU D'OUTILS POUR LES PROFESSIONNELS  
TROLLEY 179 PIEZAS DE UTENSILIOS PARA PROFESIONALES

**NEW!**

179  
pcs.



cricchetto  
ratchet



470 X 210 X 380 mm





## FOCUS ON



Valigetta con quattro vassoi interni completi di tutti gli utensili necessari al lavoro dei professionisti di tutti i settori, in un robusto trolley resistente agli urti.

Case with four internal trays complete with all the tools necessary for the work of professionals in all sectors, in a robust shock-resistant trolley.

Malette avec quatre plateaux internes dotés de tous les outils nécessaires au travail de professionnels de tous les secteurs, dans un chariot solide et résistant aux chocs.

Maletín con cuatro bandejas internas equipado con todas las herramientas necesarias para el trabajo de profesionales de todos los sectores, en un carro robusto y resistente a los golpes.



COD. **64230304**

€ 398,000

	3,0 4,0 5,0 7,0
	PH0 PH1 PH2 PH3
	PZ0 PZ1 PZ2 PZ3
	TX8 TX9 TX10 TX15 TX20 TX25 TX27 TX30 TX40
	1,5 2 2,5 3 4 5 5,5 6 8
	4 4,5 5 5,5 6 7 8
	9 10 11 12 13
	10 11 12 13 14 15 16
	17 18 19 20 21 22 24
	8 10 11 12 13 14 17 19 22
	1,5 2 2,5 3 4 5 6 8 10
	50 100
	125 250
	40
	80
	16
	21

	6x75 6x100 8x150		6
	PH1x75 PH2x100	L=38mm	PH2
	LED		TESTER 250V
	200mm		180mm
	160mm		10 pcs
	160mm		180mm
	160mm		300mm
	200mm		3 pcs
	5 pcs		300gr
	5m		200mm
	200mm		50 pcs



# 3 BUSSOLE E ACCESSORI

SOCKETS AND ACCESSORIES  
DOUILLES ET ACCESSOIRES  
VASOS Y ACCESORIOS

64230

## VALIGETTA UTENSILI MANUALI CON BUSSOLE E ACCESSORI 1/4" 1/2"

ASSORTIMENTO 55 PCS BUSSOLE ED ACCESSORI 1/4", 1/2" VALIGETTA IN TERMOFORMATO  
55 PCS 1/4"-1/2" SOCKETS AND ACCESSORIES SET IN BLOW MOLD CASE  
JEU 55 PCS DOUILLES ET ACCESSOIRES 1/4"-1/2" DANS VALISE DE MOULE DE SOUFFLE  
JUEGO DE 55 PCS VASOS Y ACCESORIOS DE 1/4"-1/2" EN MALETIN DE MOLDE

**NEW!**

55  
pcs.



380 X 80 X 330 mm



COD. **64230340**

€ 96,700

		3,0	4,0	5,0	6,0		
		PH1	PH2	PH3			
		TX10	TX15	TX20	TX25	TX27	TX30
		8	9	10	11	12	13
		10	12	13	14	15	17
		22	24	27			
		10	12	13	14	15	17
		250mm					180mm
							200gr
		16					
		21					
		6	8				
		PH2					
				125			2
							2,5
							3
							4



64230

# VALIGETTA UTENSILI MANUALI CON BUSSOLE E ACCESSORI 1/4" 1/2"

ASSORTIMENTO 89 PCS BUSSOLE ED ACCESSORI 1/4", 1/2" VALIGETTA IN TERMOFORMATO  
89 PCS 1/4"-1/2" SOCKETS AND ACCESSORIES SET IN BLOW MOLD CASE  
JEU 89 PCS DOUILLES ET ACCESSOIRES 1/4"-1/2" DANS VALISE DE MOULDE DE SOUFFLE  
JUEGO DE 89 PCS VASOS Y ACCESORIOS DE 1/4"-1/2" EN MALETIN DE MOLDE

**NEW!**

89  
pcs.

COD. **64230320**

€ **133,400**



440 X 100 X 350 mm



	3,0	4,5	5,0	6,0	7,0					
	PH1	PH2	PH3							
	PZ1	PZ2	PZ3							
	TX10	TX15	TX20	TX25	TX27	TX30	TX40			
	TXH15	TXH20	TXH25	TXH30						
	1,5	2	2,5	3	4	5	6	8		
		4	4,5	5	5,5	6	7	8		
		9	10	11	12	13	14			
		15	16	17	18	19	20	21		
		22	24	27						
	1,5	2	2,5				8	10	12	
	3	4	5				13	14	15	
	6	8	10				17			
		140mm							130mm	
		160mm							160mm	
		200mm							180mm	
		250mm							TESTER 250V	
		3m							200gr	
		3	6							125
		PH1	PH2							



# 3 BUSSOLE E ACCESSORI

SOCKETS AND ACCESSORIES  
DOUILLES ET ACCESSOIRES  
VASOS Y ACCESORIOS

**64230**

**VALIGETTA A TENUTA STAGNA  
BUSSOLE E ACCESSORI 1/4" 3/8"**

ASSORTIMENTO 82 PCS BUSSOLE ED ACCESSORI 1/4" 3/8" VALIGIA A TENUTA STAGNA  
82 PCS 1/4" 3/8" SOCKETS AND ACCESSORIES SET IN WATERPROOF CASE  
JEU 82 PCS DOUILLES ET ACCESSOIRES 1/4" 3/8" DANS VALISE IMPERMEABLE  
JUEGO DE 82 PCS VASOS Y ACCESORIOS DE 1/4" 3/8" EN MALETIN A PRUEBA DE AGUA

**NEW!**

82  
pcs.

**WATERPROOF**

COD. **64230322**

€ 257,800



460 X 180 X 360 mm



	4	4,5	5	5,5	6	7	8
	9						
	10	11	12	13	14	15	17
	18 19						
	160mm		3pcs				
	160mm		180mm				
	250mm		TESTER 250V				
	5m		200gr				
	3,0	4,0	2pcs. 6,0	7,0			
		2pcs. PH1	2pcs. PH2	2pcs. PH3			
	2pcs. PZ1	2pcs. PZ2	PZ3				
	TX10	TX15	TX20	TX25	TX27	TX30	
	2,5	3	4	5	5,5	6	
	1,5	2	2,5	6x7		8x9	
	3	4	5	10x11		12x13	
	6	8	10	14x15 16x17			
							21
	3	5					





*Le conoscenze maturate con gli utensili per avvitatori ci permettono di offrire anche una gamma base di utensili manuali di alta qualità. Una gamma base di tipologie usate in operazioni di avvitatura, corredate di assortimenti e confezioni dedicati all'esposizione in punto vendita.*

*The knowledge gained from the production of tools for screwdrivers allows us to offer a basic range of high-quality hand tools to complement the range offered in the previous chapters, and the range of tips used in screwing operations, equipped with different collections and packaging for store displays.*

*Les connaissances acquises avec la production d'outils pour les visseuses nous permettent d'offrir une gamme de base d'outils manuels de haute qualité pour compléter le programme offert dans les chapitres précédents. Une gamme d'empreintes utilisées dans les opérations de vissage, accompagnée d'assortiments et d'emballages dédiés à l'exposition dans les points de vente.*

*Los conocimientos adquiridos con la producción de los utensilios para atornilladores nos permiten ofrecer una gama base de utensilios manuales de alta calidad para completar el programa ofrecido en los capítulos precedentes. Una gama de tipos de huellas que se emplean en las operaciones de atornillado, con muchos accesorios y lista para la exposición en un punto venta.*



# 4

## UTENSILI MANUALI HAND TOOLS OUTILS À MAIN UTENSILIOS MANUALES



**GIRAVITE**  
SCREWDRIVERS • TOURNEVIS •  
DESTORNILLADORES p. 378



**GIRAVITI 1000V VDE**  
1000V VDE SCREWDRIVERS •  
TOURNEVIS 1000V VDE •  
DESTORNILLADORES 1000V VDE p. 386



**5 IN 1**  
5 IN 1 • 5 EN 1 • 5 EN 1 p. 392



**5 IN 1 NANO**  
5 IN 1 NANO • 5 EN 1 NANO •  
5 EN 1 NANO p. 393



**GIRAVITE A  
CRICCHETTO**  
RATCHET SCREWDRIVERS •  
TOURNEVIS À CLIQUET •  
DESTORNILLADOR CON  
MECANISMO DE TRINQUETE p. 394



**LAME DOPPIE DI  
PRECISIONE**  
DOUBLE PRECISION  
SCREWDRIVER BLADE • LAMES  
DOUBLES DE PRECISION •  
PUNTAS DOBLE DE PRECISION p. 398



**CHIAVI PER  
CENTRALINE**  
WRENCHES FOR CONTROL UNITS •  
CLÉ POUR CENTRALES •  
LLAVE PARA CENTRALITAS p. 400



**PUNZONI**  
PUNCHES • POINÇONS •  
PUNZONES p. 401



**CHIAVI MASCHIO**  
MALE WRENCHES • CLÉ MÂLE •  
LLAVES MACHO p. 402



**CHIAVI COMBinate**  
COMBINATION WRENCHES •  
CLÉS MIXTES •  
SURTIDO DE LLAVES p. 420



**CHIAVI A CRICCHETTO**  
RATCHET WRENCHES •  
CLÉS À CLIQUET • LLAVES CON  
MECANISMO DE TRINQUETE p. 424



**CHIAVI A CRICCHETTO  
E SNODO**  
RATCHET AND JOINTED  
WRENCHES • CLÉS À CLIQUET ET  
ARTICULATION • LLAVES CON  
MECANISMO DE TRINQUETE Y  
ARTICULACIÓN p. 426



**CHIAVI COLORATE**  
COLOUR SERIES WRENCHES •  
CLÉS SÉRIE COLOUR •  
LLAVES SERIE COLOUR p. 428



**CHIAVI CON STOP-RING**  
WRENCHES WITH STOP-RING •  
CLÉS AVEC SYSTÈME STOP-RING •  
LLAVES CON SISTEMA STOP-RING p. 429



**CHIAVE PER PONTEGGI**  
WRENCHES FOR SCAFFOLDING •  
CLÉS POUR ÉCHAFAUDAGES •  
LLAVES PARA ANDAMIOS p. 429



**ASSORTIMENTO  
UTENSILI MANUALI**  
HAND TOOLS SET • JEU DE  
OUTILS MANUEL • JUEGO DE  
HERRAMIENTAS DE MANO p. 430



**LAMPADe A LED  
RICARICABILI**  
RECHARGEABLE LED LAMPS •  
LAMPES À LED RECHARGEABLES •  
LÁMPARAS LED RECARGABLES p. 434



**CONTENITORI PORTA-  
UTENSILI**  
TOOL CONTAINERS •  
CONTENEURS PORTE-UTENSILES •  
CONTENEDORES PORTAUTENSILIOS p. 442





# 4 UTENSILI MANUALI

MANUAL TOOLS  
OUTILS À MAIN  
UTENSILIOS MANUALES

## 65001 GIRAVITE A TAGLIO

GIRAVITE LAMA A TAGLIO MANICO IN BICOMPONENTE  
SLOTTED SCREWDRIVERS WITH BICOMPONENT HANDLE  
TOURNEVIS LAME À FENTE MANCHE DEUX COMPOSANTS  
DESTORNILLADORES CON LAMA DE CORTE Y MANGO BICOMPUESTO

**EASYPACK** | scatola di cartone + cardboard box

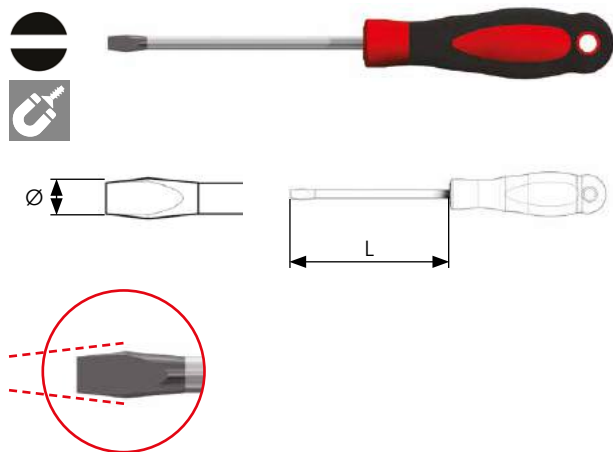

Ø mm	L mm	PCS.	COD.	€ cad./each	
0,5	3	75	6	65001005	2,820
	3	100	6	65001007	3,490
0,8	4	100	6	65001010	3,490
	4	125	6	65001012	4,380
1	5,5	125	6	65001015	4,220
	5,5	150	6	65001017	5,150
1,2	6,5	150	6	65001020	5,150
	8	150	6	65001025	6,970
	8	200	6	65001027	8,310

Ø mm	COD.	€ box	
0,5	3	65001005001	4,160
	3	65001007001	4,820
0,8	4	65001010001	4,820
	4	65001012001	5,720
1	5,5	65001015001	5,560
	5,5	65001017001	6,490
	6,5	65001020001	6,490
1,2	8	65001025001	8,310
	8	65001027001	9,650



**SELPACK**  
1 pc.

## 65001 GIRAVITE NANO A TAGLIO

GIRAVITE NANO LAMA A TAGLIO MANICO IN BICOMPONENTE  
STUBBY SLOTTED SCREWDRIVER WITH BICOMPONENT HANDLE  
TOURNEVIS NANO LAME À FENTE MANCHE DEUX COMPOSANTS  
DESTORNILLADOR NANO CON LAMA DE CORTE Y MANGO BICOMPUESTO

**EASYPACK** | scatola di cartone + cardboard box

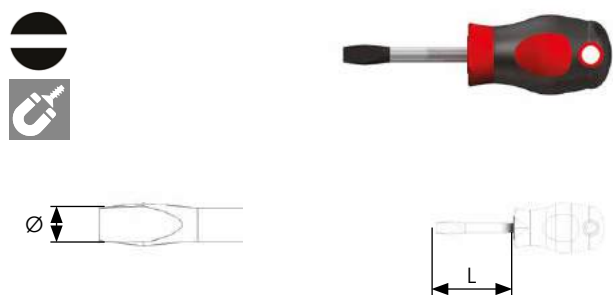

Ø mm	L mm	PCS.	COD.	€ cad./each	
1,2	6,5	38	6	65001120	3,350



**SELPACK**  
1 pc.

Ø mm	COD.	€ box	
1,2	6,5	65001120001	4,690



### FOCUS ON



Testa del manico semisferica per maggior comfort. Profilo impugnatura ergonomico per miglior presa e trasmissione della forza. 2 materiali: antiscivolo e resistente.

Hemispherical head handle for greater comfort. Ergonomic handle for better grip and transmission of the force. 2 materials: nonslip and resistant.

Tête du manche semi-sphérique pour plus de confort. Profil de la poignée ergonomique pour une meilleure adhérence et transmission de la force. 2 matériaux : anti-dérapant et résistant.

Cabeza del mango semi-esférica para mayor comodidad. Perfil con mango ergonómico para mejorar el agarre y la transmisión de la fuerza. 2 materiales: antideslizante y resistente.



## 65002 GIRAVITE A TAGLIO

GIRAVITE LAMA DRITTA A TAGLIO MANICO IN BICOMPONENTE  
 STRAIGHT SLOTTED SCREWDRIVER WITH BICOMPONENT HANDLE  
 TOURNEVIS LAME DROITE À FENTE MANCHE DEUX COMPOSANTS  
 DESTORNILLADORES CON LAMA DERECHA DE CORTE Y MANGO BICOMPUESTO

**EASYPACK** | scatola di cartone • cardboard box

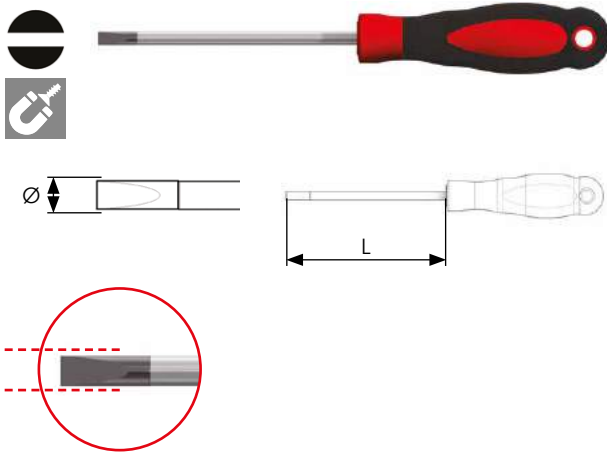

Ø mm	L mm	PCS.	COD.	€ cad./each	
0,5	3	75	6	65002005	3,020
0,6	3,5	200	6	65002207	6,880
0,8	4	100	6	65002010	3,620
0,8	4	300	6	65002210	7,880
0,8	5	125	6	65002015	4,500
1	5	200	6	65002218	7,690
1	6	150	6	65002020	5,070
1,2	8	300	6	65002225	12,500

Ø mm	COD.	€ box	
0,5	3	65002005001	4,360
0,8	4	65002010001	4,960
0,8	5	65002015001	5,840
1	6	65002020001	6,400

**SELPACK**  
1 pc.

## 65999 CERCAFASE

GIRAVITE CERCAFASE  
 TESTER  
 TOURNEVIS TESTEUR  
 DESTORNILLADOR BUSCAPOLOS

250 V

**EASYPACK** | scatola di cartone • cardboard box

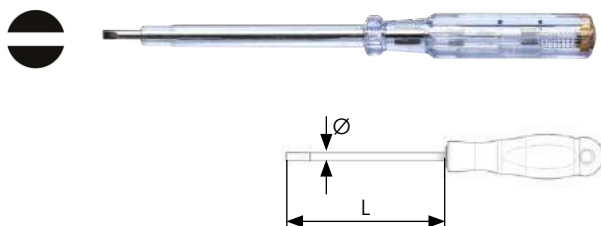

Ø mm	L mm	PCS.	COD.	€ cad./each	
0,6	3	60	6	65999001	3,000





# 4 UTENSILI MANUALI

MANUAL TOOLS  
OUTILS À MAIN  
UTENSILIOS MANUALES

## 65003 GIRAVITE A CROCE PH

GIRAVITE LAMA A CROCE PHILLIPS® MANICO IN BICOMPONENTE  
PHILLIPS® SCREWDRIVER WITH BICOMPONENT HANDLE  
TOURNEVIS LAME CRUCIFORME PHILLIPS® MANCHE DEUX COMPOSANTS  
DESTORNILLADORES CON LAMA DE CRUZ PHILLIPS® CON MANGO BICOMPUESTO

**EASYPACK** | scatola di cartone + cardboard box

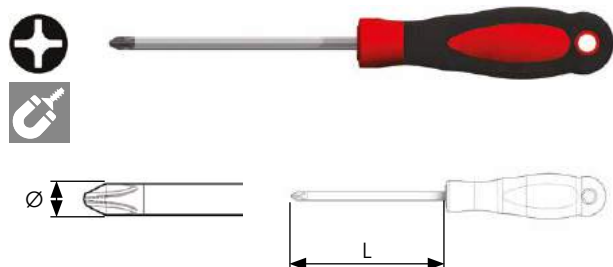

+	L mm	Ø mm	PCS.	COD.	€ cad./each
PH0	75	3	6	65003005	3,140
	100	3	6	65003007	3,610
PH1	80	5	6	65003010	3,790
	125	5	6	65003013	4,860
PH2	300	5	6	65003210	7,410
	100	6	6	65003015	4,620
PH2	150	6	6	65003018	5,750
	300	6	6	65003215	8,470
PH3	150	8	6	65003020	7,720

+	Ø mm	COD.	€ box
PH0	3	65003005001	4,480
	3	65003007001	4,950
PH1	5	65003010001	5,130
	5	65003013001	6,200
PH2	6	65003015001	5,960
	6	65003018001	7,090
PH3	8	65003020001	9,060



**SELPACK**  
1 pc.

## 65003 GIRAVITE NANO A CROCE PH

GIRAVITE NANO LAMA A CROCE PHILLIPS® MANICO IN BICOMPONENTE  
PHILLIPS® STUBBY SCREWDRIVER WITH BICOMPONENT HANDLE  
TOURNEVIS NANO LAME CRUCIFORME PHILLIPS® MANCHE DEUX COMPOSANTS  
DESTORNILLADORES NANO CON LAMA DE CRUZ PHILLIPS® CON MANGO BICOMPUESTO

**EASYPACK** | scatola di cartone + cardboard box

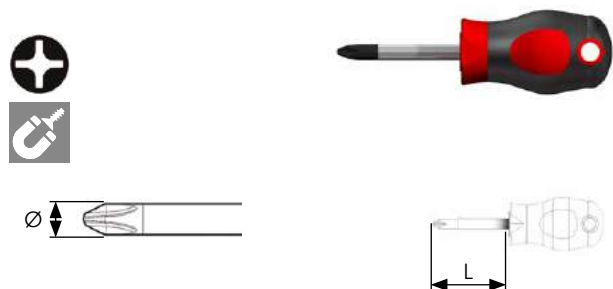

+	L mm	Ø mm	PCS.	COD.	€ cad./each
PH1	38	5	6	65003110	3,660
PH2	38	6	6	65003115	3,710



**SELPACK**  
1 pc.

+	COD.	€ box
PH1	65003110001	5,000
PH2	65003115001	5,050



## 65004 GIRAVITE A CROCE PZ

GIRAVITE LAMA A CROCE POZIDRIV® MANICO IN BICOMPONENTE  
POZIDRIV® SCREWDRIVER WITH BICOMPONENT HANDLE  
TOURNEVIS LAME CRUCIFORME POZIDRIV® MANCHE DEUX COMPOSANTS  
DESTORNILLADORES CON LAMA DE CRUZ POZIDRIV® CON MANGO BICOMPUESTO

**EASYPACK** | scatola di cartone • cardboard box

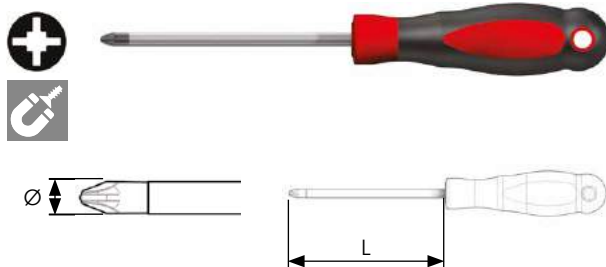

+	L mm	Ø mm	PCS.	COD.	€ cad./each
<b>PZ0</b>	75	<b>3</b>	6	65004005	<b>3,140</b>
<b>PZ1</b>	80	<b>5</b>	6	65004010	<b>3,790</b>
<b>PZ2</b>	100	<b>6</b>	6	65004015	<b>4,620</b>
<b>PZ3</b>	150	<b>8</b>	6	65004020	<b>7,720</b>

+	Ø mm	COD.	€ box
<b>PZ0</b>	<b>3</b>	65004005001	<b>4,480</b>
<b>PZ1</b>	<b>5</b>	65004010001	<b>5,130</b>
<b>PZ2</b>	<b>6</b>	65004015001	<b>5,960</b>
<b>PZ3</b>	<b>8</b>	65004020001	<b>9,060</b>

**SELPACK**  
1 pc.

## 65005 GIRAVITE IMPRONTA TX

GIRAVITE PER VITI TORX® MANICO IN BICOMPONENTE  
SCREWDRIVERS FOR TORX® SCREWS WITH BICOMPONENT HANDLE  
TOURNEVIS POUR VIS TORX® MANCHE DEUX COMPOSANTS  
DESTORNILLADORES PARA TORNILLOS TORX® CON MANGO BICOMPUESTO

**EASYPACK** | scatola di cartone • cardboard box

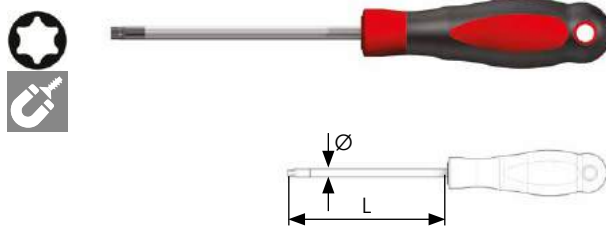

⊛	L mm	Ø mm	PCS.	COD.	€ cad./each
<b>TX5</b>	60	<b>3</b>	6	65005005	<b>3,210</b>
<b>TX6</b>	60	<b>3</b>	6	65005010	<b>3,210</b>
<b>TX7</b>	60	<b>3</b>	6	65005015	<b>3,210</b>
<b>TX8</b>	60	<b>3</b>	6	65005020	<b>3,210</b>
<b>TX9</b>	60	<b>4</b>	6	65005025	<b>3,210</b>
<b>TX10</b>	80	<b>4</b>	6	65005029	<b>3,180</b>
	250	<b>4</b>	6	65005229	<b>8,040</b>
<b>TX15</b>	80	<b>4</b>	6	65005034	<b>3,750</b>
	250	<b>4</b>	6	65005234	<b>8,040</b>
<b>TX20</b>	100	<b>4</b>	6	65005039	<b>3,900</b>
	250	<b>4</b>	6	65005239	<b>8,040</b>
<b>TX25</b>	100	<b>5</b>	6	65005044	<b>4,630</b>
	250	<b>5</b>	6	65005244	<b>8,040</b>
<b>TX30</b>	100	<b>6</b>	6	65005054	<b>4,700</b>
	250	<b>6</b>	6	65005254	<b>8,040</b>
<b>TX40</b>	125	<b>8</b>	6	65005059	<b>7,600</b>

⊛	COD.	€ box
<b>TX5</b>	65005005001	<b>4,540</b>
<b>TX6</b>	65005010001	<b>4,540</b>
<b>TX7</b>	65005015001	<b>4,540</b>
<b>TX8</b>	65005020001	<b>4,540</b>
<b>TX9</b>	65005025001	<b>4,540</b>
<b>TX10</b>	65005029001	<b>4,460</b>
<b>TX15</b>	65005034001	<b>5,100</b>
<b>TX20</b>	65005039001	<b>5,250</b>
<b>TX25</b>	65005044001	<b>6,000</b>
<b>TX30</b>	65005054001	<b>6,130</b>
<b>TX40</b>	65005059001	<b>9,060</b>

**SELPACK**  
1 pc.





# 4 UTENSILI MANUALI

MANUAL TOOLS  
OUTILS À MAIN  
UTENSILIOS MANUALES

**65005**

## GIRAVITE IMPRONTA TXH

GIRAVITE PER VITI TORX® MANICO IN BICOMPONENTE  
SCREWDRIVERS FOR TORX® SCREWS WITH BICOMPONENT HANDLE  
TOURNEVIS POUR VIS TORX® MANCHE DEUX COMPOSANTS  
DESTORNILLADORES PARA TORNILLOS TORX® CON MANGO BICOMPUESTO

**EASYPACK** | scatola di cartone + cardboard box

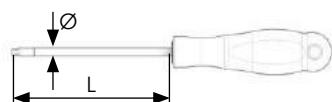

	L mm	Ø mm	PCS.	COD.	€ cad./each
<b>TXH10</b>	80	<b>4</b>	6	65005030	<b>3,280</b>
<b>TXH15</b>	80	<b>4</b>	6	65005035	<b>3,860</b>
<b>TXH20</b>	100	<b>4</b>	6	65005040	<b>3,980</b>
<b>TXH25</b>	100	<b>5</b>	6	65005045	<b>4,730</b>
<b>TXH27</b>	100	<b>5</b>	6	65005050	<b>4,730</b>
<b>TXH30</b>	100	<b>6</b>	6	65005055	<b>4,850</b>
<b>TXH40</b>	125	<b>8</b>	6	65005060	<b>7,740</b>



	COD.	€ box
<b>TXH10</b>	65005030001	<b>4,620</b>
<b>TXH15</b>	65005035001	<b>5,200</b>
<b>TXH20</b>	65005040001	<b>5,320</b>
<b>TXH25</b>	65005045001	<b>6,070</b>
<b>TXH27</b>	65005050001	<b>6,070</b>
<b>TXH30</b>	65005055001	<b>6,190</b>
<b>TXH40</b>	65005060001	<b>9,080</b>



**SELPACK**  
1 pc.



*Dettaglio di una casa in costruzione.  
A house under construction.  
Détail d'une maison en construction.  
Detalle de una casa en construcción.*



# 4 UTENSILI MANUALI

MANUAL TOOLS  
OUTILS À MAIN  
UTENSILIOS MANUALES

## 65006 ASSORTIMENTI GIRAVITE

ASSORTIMENTI 6 PCS. GIRAVITE  
6 PCS. SCREWDRIVERS SETS  
JEUX DE 6 PIÈCES TOURNEVIS  
JUEGOS DE 6 PIEZAS DE DESTORNILLADORES









6  
pcs.

160 X 290 X 35 mm





COD. **65006005**

€ 25,500

65003 		65004 		65001 	
					
PH1x80	PH2x100	PZ1x80	PZ2x100	4,0x100	6,5x150
1pc.	1pc.	1pc.	1pc.	1pc.	1pc.



COD. **65006010**

€ 24,100

65004 		65001 			
					
PZ1x80	PZ2x100	3,0x75	4,0x100	5,5x125	6,5x150
1pc.	1pc.	1pc.	1pc.	1pc.	1pc.





COD. **65006020**

€ 27,800

65005 					
					
TX10x80	TX15x80	TX20x100	TX25x100	TX30x100	TX40x125
1pc.	1pc.	1pc.	1pc.	1pc.	1pc.

COD. **65006015**

€ 24,600

65003 		65002 			
					
PH1x80	PH2x100	4,0x100	5,0x125	6,0x150	
1pc.	1pc.	1pc.	1pc.	1pc.	

INCLUSO / INCLUDED / INCLUSE / INCLUIDO

COD. 65999001



### TIPS



Magnetizzatore/smagnetizzatore COD. 65011005 p. 232  
Magnétiser/démagnétiser COD. 65011005 p. 232  
Magnétiseur/démagnétiseur COD. 65011005 p. 232  
Bloque de magnetización/desmagnetización COD. 65011005 p. 232



Bussola magnetica per GIRAVITE fino COD. 65011010 p. 232  
Magnetic socket for screwdrivers up to COD. 65011010 p. 232  
Douille magnétique pour tournevis jusqu'au COD. 65011010 p. 232  
Vaso magnético para destornilladores COD. 65011010 p. 232





# 65007 ESPOSITORE GIRAVITE

ESPOSITORE DA BANCO GIRAVITE  
 COUNTER DISPLAY FOR SCREWDRIVERS  
 PRÉSENTOIR DE COMPTOIR TOURNEVIS  
 MOSTRADOR DE EXPOSICIÓN DE DESTORNILLADORES



144  
pcs.

450 X 320 X 200 mm

COD. **65007005**

€ 598,000

65003 			65004 		
PH0x75 12pcs.	PH1x80 12pcs.	PH2x100 12pcs.	PZ0x80 12pcs.	PZ1x80 12pcs.	PZ2x100 12pcs.
65001 					65002 
3,0x75 12pcs.	4,0x100 12pcs.	5,5x125 12pcs.	6,5x150 12pcs.	8,0x150 12pcs.	5,0x125 12pcs.

COD. **65007010**

€ 598,000

65005 						
TX5x60 12pcs.	TX6x60 12pcs.	TX7x60 12pcs.	TX8x60 12pcs.	TX9x60 12pcs.		
65005 						
TX10 x80 12pcs.	TX15 x80 12pcs.	TX20 x100 12pcs.	TX25 x100 12pcs.	TX27 x100 12pcs.	TX30 x100 12pcs.	TX40 x125 12pcs.





# 4 UTENSILI MANUALI

MANUAL TOOLS  
OUTILS À MAIN  
UTENSILIOS MANUALES

## 65022 GIRAVITE ISOLATO 1000V VDE A TAGLIO

GIRAVITE 1000V VDE LAMA A TAGLIO MANICO IN BICOMPONENTE  
1000V VDE SLOTTED SCREWDRIVERS WITH BICOMPONENT HANDLE  
TOURNEVIS 1000V VDE LAME À FENTE MANCHE DEUX COMPOSANTS  
DESTORNILLADORES 1000V VDE CON LAMA DE CORTE Y MANGO BICOMPUESTO

**EASYPACK** | scatola di cartone + cardboard box

**NEW!**

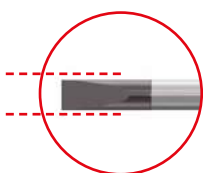
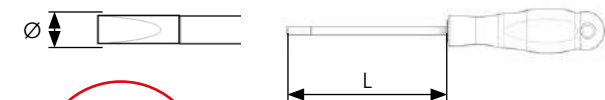

Ø mm	L mm	PCS.	COD.	€ cad./each
0,4	2,5	75	65022003	4,200
0,8	4	100	65022010	4,800
1,0	5,5	125	65022015	5,300
1,2	6,5	150	65022020	5,900
1,2	8	175	65022025	9,400

Ø mm	COD.	€ cad./each
0,4	2,5	65022003001 5,450
0,8	4	65022010001 6,050
1,0	5,5	65022015001 3,850
1,2	6,5	65022020001 6,550
1,2	8	65022025001 10,650

**SELPACK**  
1 pc.

## 65023 GIRAVITE ISOLATO 1000V VDE A CROCE PHILLIPS®

GIRAVITE 1000V VDE LAMA A CROCE PHILLIPS® MANICO IN BICOMPONENTE  
1000V VDE PHILLIPS® SCREWDRIVER WITH BICOMPONENT HANDLE  
TOURNEVIS 1000V VDE LAME CRUCIFORME PHILLIPS® MANCHE DEUX COMPOSANTS  
DESTORNILLADORES 1000V VDE CON LAMA DE CRUZ PHILLIPS® CON MANGO BICOMPUESTO

**EASYPACK** | scatola di cartone + cardboard box

**NEW!**



Ø mm	L mm	PCS.	COD.	€ cad./each
PH0	3	75	65023005	3,500
PH1	4,5	80	65023010	4,200
PH2	6	100	65023015	5,300

Ø mm	COD.	€ cad./each
PH0	3	65023005001 4,750
PH1	4,5	65023010001 5,450
PH2	6	65023015001 6,550

**SELPACK**  
1 pc.



## 65024 GIRAVITE ISOLATO 1000V VDE A CROCE POZIDRIV®

GIRAVITE 1000V VDE LAMA A CROCE POZIDRIV® MANICO IN BICOMPONENTE  
 1000V VDE POZIDRIV® SCREWDRIVER WITH BICOMPONENT HANDLE  
 TOURNEVIS 1000V VDE LAME CRUCIFORME POZIDRIV® MANCHE DEUX COMPOSANTS  
 DESTORNILLADORES 1000V VDE CON LAMA DE CRUZ POZIDRIV® CON MANGO BICOMPUESTO

**NEW!**

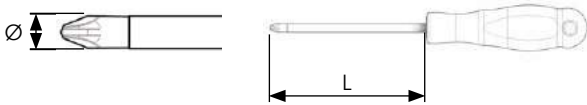

**EASYPACK** | scatola di cartone + cardboard box

+	Ø mm	L mm	PCS.	COD.	€ cad./each
PZ1	4,5	80	6	65024010	4,200
PZ2	6	100	6	65024015	5,300
PZ3	8	150	6	65024020	9,300



**SELPACK**  
1 pc.

+	Ø mm	COD.	€ cad./each
PZ1	4,5	65024010001	5,450
PZ2	6	65024015001	6,550
PZ3	8	65024020001	10,550

## 65026 ASSORTIMENTI GIRAVITE ISOLATO 1000V VDE

ASSORTIMENTI 5-6 PCS. GIRAVITE 1000V VDE  
 5-6 PCS. 1000V VDE SCREWDRIVERS SETS  
 JEUX DE 5-6 PIÈCES TOURNEVIS 1000V VDE  
 JUEGOS DE 5-6 PIEZAS DE DESTORNILLADORES 1000V VDE



5  
pcs.

COD. <b>65026005</b>				
€ 23,500				
65023	65022			
PH1x80 1pc.	PH2x100 1pc.	2,5x75 1pc.	4,0x100 1pc.	5,5x125 1pc.

COD. <b>65026010</b>				
€ 23,500				
65024	65022			
PZ1x80 1pc.	PZ2x100 1pc.	2,5x75 1pc.	4,0x100 1pc.	5,5x125 1pc.

6  
pcs.

COD. <b>65026015</b>						
€ 28,000						
65023				65022		
PH0x75 1pc.	PH1x80 1pc.	PH2x100 1pc.	2,5x75 1pc.	4,0x100 1pc.	5,5x125 1pc.	

160 X 290 X 35 mm



# 4 UTENSILI MANUALI

MANUAL TOOLS  
OUTILS À MAIN  
UTENSILIOS MANUALES

**65006**

## ASSORTIMENTI LAME 1000V VDE INTERCAMBIABILI

ASSORTIMENTO 9 PCS. LAME 1000V VDE INTERCAMBIABILI CON IMPUGNATURA  
9 PIECE ASSORTMENT BLADE 1000V VDE INTERCHANGEABLE WITH HANDLE ASSORTI-  
MENT 9 PCS. LAME 1000V VDE INTERCHANGEABLE AVEC POIGNÉE  
SURTIDO 9 PIEZAS HOJAS 1000 V VDE INTERCAMBIABLES CON MANGO

**NEW!**

9  
pcs.

COD. **65006185**  
€ 46,500



●				⊕		
0,4x2,5 1pc.	0,6x3,5 1pc.	1,0x5,5 1pc.	1,2x6,5 1pc.	PH0 1pc.	PH1 1pc.	PH2 1pc.

INCLUSO / INCLUDED  
INCLUDE / INCLUIDO



EURO-HOLE

105 X 47 X 220 mm





**65006**

**ASSORTIMENTI LAME  
1000V VDE INTERCAMBIABILI**

ASSORTIMENTO 18 PCS. LAME 1000V VDE INTERCAMBIABILI CON IMPUGNATURA  
18 PIECE ASSORTMENT BLADE 1000V VDE INTERCHANGEABLE WITH HANDLE ASSORTIMENT  
18 PCS. LAME 1000V VDE INTERCHANGEABLE AVEC POIGNÉE  
SURTIDO 18 PIEZAS HOJAS 1000 V VDE INTERCAMBIABLES CON MANGO

**NEW!**

18  
pcs.

COD. **65006190**

€ 72,500



		-		+		+	
3,0 1pc.	4,0 1pc.	5,5 1pc.	6,5 1pc.	PH1 1pc.	PH2 1pc.	PZ1 1pc.	PZ2 1pc.
+		+		○	△	□	
PH1 1pc.	PH2 1pc.	PZ1 1pc.	PZ2 1pc.	5,3 1pc.	9 1pc.	6 1pc.	8 1pc.

INCLUSO / INCLUDED  
INCLUDE / INCLUIDO



EURO-HOLE

120 X 65 X 220 mm



**FOCUS ON**



Quattro chiavi con le impronte più comuni per aprire le cassette ed i quadri elettrici e lavorare in tutta sicurezza.

Four keys with the most common prints required to open boxes and the electrical panels and work in complete safety.

Quatre clés avec les empreintes les plus courantes pour ouvrir les boîtes et les tableaux électriques et travailler en toute sécurité.

Cuatro llaves con las huellas más comunes para abrir las cajas y los paneles eléctricos y trabajar con total seguridad.





# 4 UTENSILI MANUALI

MANUAL TOOLS  
OUTILS À MAIN  
UTENSILIOS MANUALES

**65007**

**ESPOSITORE GIRAVITE  
ISOLATO 1000V VDE**

ESPOSITORE DA BANCO GIRAVITE 1000V VDE  
COUNTER DISPLAY FOR 1000V VDE SCREWDRIVERS  
PRÉSENTOIR DE COMPTOIR TOURNEVIS 1000V VDE  
MOSTRADOR DE EXPOSICIÓN DE DESTORNILLADORES 1000V VDE

**NEW!**





144  
pcs.



450 X 320 X 200 mm

COD. **65007015**

€ 698,000

65023 			65024 		
PH0x75 12pcs.	PH1x80 12pcs.	PH2x100 12pcs.	PZ0x80 12pcs.	PZ1x80 12pcs.	PZ2x100 12pcs.
65001 					65999 
3,0x75 12pcs.	4,0x100 12pcs.	5,5x125 12pcs.	6,5x150 12pcs.	8,0x150 12pcs.	250 V 12pcs.



# GIRAVITI 1000V VDE

1000V VDE SCREWDRIVERS  
TOURNEVIS 1000V VDE  
DESTORNILLADORES 1000V VDE

## FOCUS ON

### Linea completa di giraviti testati:

- 1 Certificati secondo la normativa tedesca VDE.
- 2 Impugnatura ergonomica in bi-componente per una presa confortevole.
- 3 Lama in acciaio CrMoV di alta qualità.
- 4 Punta magnetica.

### Complete line of tested screwdrivers:

- 1 Certificates according to the German VDE regulation.
- 2 Ergonomic bi-component handle for a comfortable grip.
- 3 High quality CrMoV steel blade.
- 4 Magnetic tip.

### Gamme complète de tournevis testés :

- 1 Certificats selon la norme allemande VDE.
- 2 Poignée ergonomique à deux composants pour une prise en main confortable.
- 3 Lame en acier CrMoV de haute qualité.
- 4 Pointe magnétique.

### Línea completa de destornilladores probados:

- 1 Certificados según la normativa alemana VDE.
- 2 Mango ergonómico de dos componentes para un agarre cómodo.
- 3 Cuchilla de acero CrMoV de alta calidad.
- 4 Punta magnética.

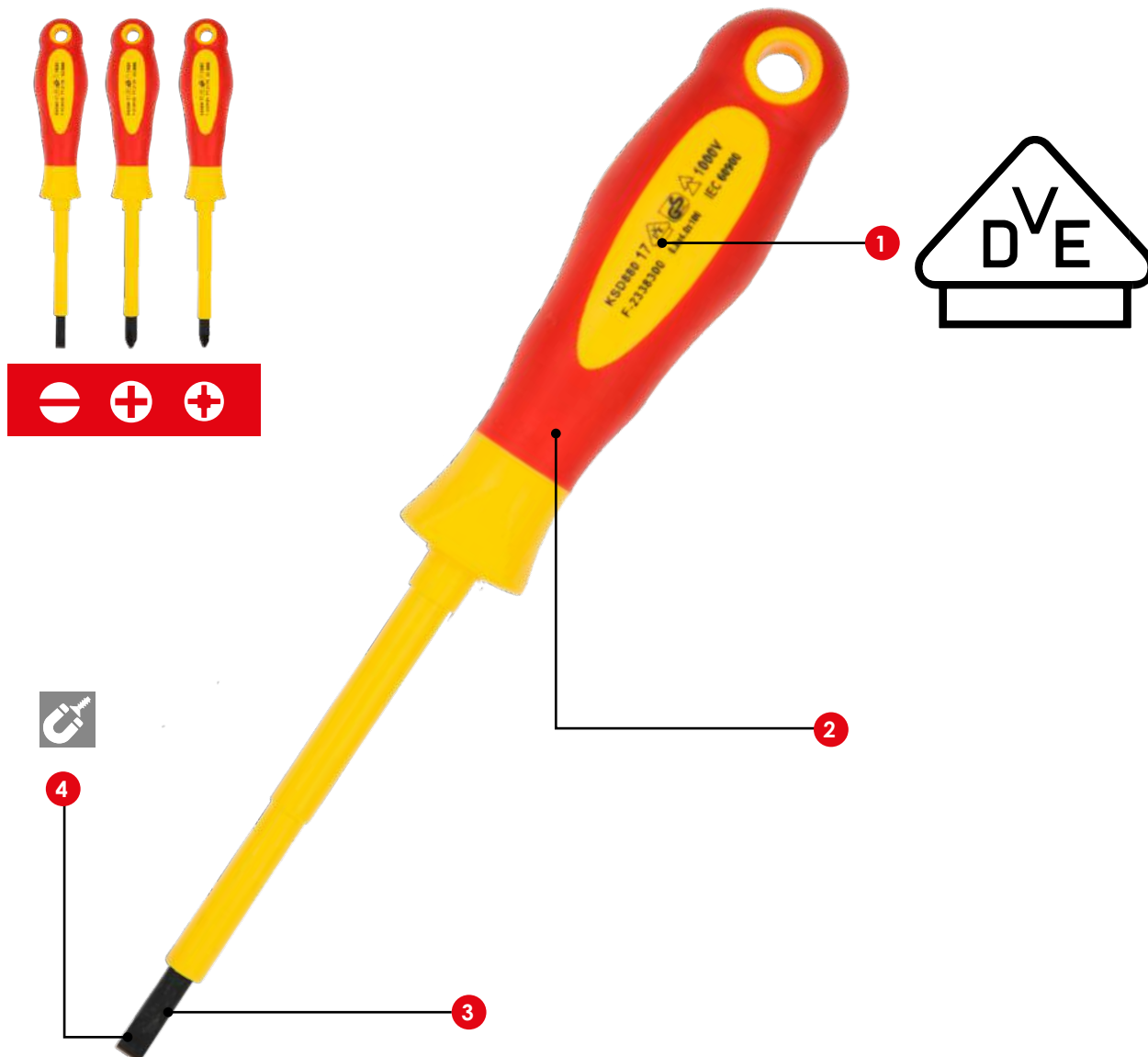



# 4 UTENSILI MANUALI

MANUAL TOOLS  
OUTILS À MAIN  
UTENSILIOS MANUALES

65006

5 IN 1

GIRAVITE 5 IN 1 CON LAMA DOPPIA ESTRAIBILE PUNTA MAGNETICA  
5 IN 1 SCREWDRIVERS WITH DOUBLE EXTRACTABLE BLADE MAGNETIC TIP  
TOURNEVIS 5 EN 1 AVEC DOUBLE LAME EXTRACTIONNÉ TÊTE AIMANTÉE  
DESTORNILLADORES 5 EN 1 CON LAMA DOBLE EXTRAÍBLE CON PUNTA MAGNÉTICA

EASYPACK | scatola di cartone • cardboard box

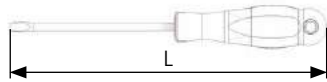

L mm	PCS.	COD.	€ cad./each
212	6	65006036	7,800



PH0 + PH1 + PH2 + PH3



1x6



## FOCUS ON



La particolare forma dell'impronta permette a questo giravite di adattarsi facilmente alle diverse misure di vite PHILLIPS® (da PH0 a PH3).

The particular shape of the tip allows this screwdriver to adapt easily to the different sizes of the PHILLIPS® screws (from PH0 to PH3).

La forme particulière de l'empreinte permet à ce tournevis de s'adapter facilement aux différentes tailles de vis PHILLIPS® (de PH0 à PH3).

La particular forma de la huella permite que este destornillador se adapte fácilmente a las diferentes medidas de tornillos PHILLIPS® (de PH0 a PH3).



65006

DISPLAY 5 IN 1

ESPOSITORE DA BANCO PER 12 PCS.  
COUNTER DISPLAY FOR 12 PCS.  
PRÉSENTOIR DE COMPTOIR POUR 12 PCS.  
MOSTRADOR DE EXPOSICIÓN PARA 12 PCS.



12  
pcs.

COD. 65006035

€ 94,000



12 pcs.  
COD. 65006036

180 X 280 X 140 mm





**65006** **5 IN 1 NANO**

GIRAVITE 5 IN 1 CON LAMA DOPPIA ESTRAIBILE PUNTA MAGNETICA  
 5 IN 1 SCREWDRIVERS WITH DOUBLE EXTRACTABLE BLADE MAGNETIC TIP  
 TOURNEVIS 5 EN 1 AVEC DOUBLE LAME EXTRAÏBLE TÊTE AIMANTÉE  
 DESTORNILLADORES 5 EN 1 CON LAMA DOBLE EXTRAÍBLE CON PUNTA MAGNÉTICA

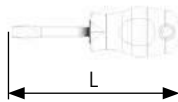

**EASYPACK** | scatola di cartone + cardboard box

L mm	PCS.	COD.	€ cad./each
92	6	65006031	6,200



PH0	+	PH1	+	PH2	+	PH3		1x6
-----	---	-----	---	-----	---	-----	--	-----

**65006** **DISPLAY 5 IN 1 NANO**

ESPOSITORE DA BANCO PER 12 PCS.  
 COUNTER DISPLAY FOR 12 PCS.  
 PRÉSENTOIR DE COMPTOIR POUR 12 PCS.  
 MOSTRADOR DE EXPOSICIÓN PARA 12 PCS.

12  
pcs.

COD. **65006030**  
 € 75,000



12 pcs.  
 COD. 65006031



180 X 175 X 140 mm





# 4 UTENSILI MANUALI

MANUAL TOOLS  
OUTILS À MAIN  
UTENSILIOS MANUALES

## 65006 CRICCHETTO NANO CON 6 INSERTI

GIRAVITE A CRICCHETTO REVERSIBILE CON 6 INSERTI 1/4"  
REVERSIBLE RATCHET SCREWDRIVER WITH 6 1/4" BITS  
TOURNEVIS À CLIQUET RÉVERSIBLE, AVEC 6 EMBOUTS 1/4"  
DESTORNILLADOR CON CARRACA REVERSIBLE CON 6 PUNTAS DE 1/4"

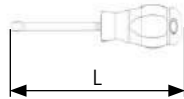

L mm	PCS.	COD.	€ cad./each
135	6	65006046	8,840



25mm PH1	25mm PH2	25mm PZ1	25mm PZ2	25mm 6,0	25mm 7,0
1pc.	1pc.	1pc.	1pc.	1pc.	1pc.

## 65006 DISPLAY CRICCHETTO NANO

ESPOSITORE DA BANCO 12 GIRAVITE A CRICCHETTO  
COUNTER DISPLAY FOR 12 RATCHET SCREWDRIVERS  
PRÉSENTOIR DE COMPTOIR 12 TOURNEVIS À CLIQUET  
MOSTRADOR DE EXPOSICIÓN DE 12 DESTORNILLADORES CON CARRACA



12  
pcs.

COD. **65006045**  
€ 89,000



12 pcs.  
COD. 65006046

200 X 230 X 155 mm



# 64221 CRICCHETTO REVERSIBILE FINGER-TWIST

SET 6 PCS. CRICCHETTO DA PALMO REVERSIBILE CON INSERTI  
6 PCS FINGER-TWIST RATCHET SET WITH BITS  
JEU 6 PCS FINGER-TWIST CLIQUET AVEC EMBOUTS  
JUEGO 6 PCS FINGER-TWIST CARRACA Y PUNTAS

**NEW!**

6 pcs.



COD. **64221001**

€ 14,000

PH1 1pc.	PH2 1pc.	PH3 1pc.	5,5x1,0 1pc.	7,0x1,2 1pc.



# 65006 GIRAVITE CRICCHETTO NANO CON 7 INSERTI 1/4\"/>

GIRAVITE A CRICCHETTO REVERSIBILE CON 7 INSERTI 1/4\"/>

35 Nm

**NEW!**

8 pcs.

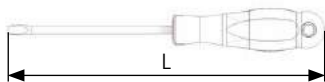

L mm	PCS.	COD.	€ cad./each
135	1	65006047	12,900



4 1pc.	5 1pc.	6 1pc.	PH1 1pc.	PH2 1pc.	TX15 1pc.	TX20 1pc.							





# 4 UTENSILI MANUALI

MANUAL TOOLS  
OUTILS À MAIN  
UTENSILIOS MANUALES

**65006**

## GIRAVITE CRICCHETTO CON 13 INSERTI

GIRAVITE A CRICCHETTO REVERSIBILE CON 13 INSERTI 1/4" C E PORTAINSERI  
REVERSIBLE RATCHET SCREWDRIVER WITH 13 PCS 1/4" C BITS AND BIT-HOLDER  
TOURNEVIS A CLIQUET REVERSIBLE AVEC 13 EMOBOUTS 1/4" C ET PORTE EMOBOUTS  
DESTORNILLADOR CON CARRACA REVERSIBLE CON 13 PUNTAS DE 1/4" C Y PORTA PUNTAS

30 Nm

**NEW!**

15  
pcs.

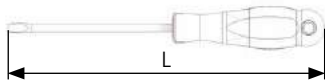

L mm	PCS.	COD.	€ cad./each
175	1	65006050	18,300



PH1 1pc.	PH2 1pc.	PH3 1pc.	PZ1 1pc.	PZ2 1pc.	PZ3 1pc.	
5 1pc.	7 1pc.	4 1pc.	5 1pc.	TX15 1pc.	TX20 1pc.	TX25 1pc.

INCLUSO / INCLUDED  
INCLUDE / INCLUIDO  
COD. 62013005



**65006**

# GIRAVITE CRICCHETTO PIEGHEVOLE CON 7 INSERTI

35 Nm

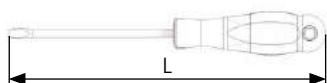
**NEW!**8  
pcs.

GIRAVITE A CRICCHETTO REVERSIBILE PIEGHEVOLE CON 7 INSERTI 1/4" C  
 REVERSIBLE FOLDABLE RATCHET SCREWDRIVER WITH 6 PCS 1/4" C BITS  
 TOURNEVIS A CLIQUET PLIABLE REVERSIBLE AVEC 7 EMOBOUTS 1/4" C  
 DESTORNILLADOR CON CARRACA REVERSIBLE Y PLEGABLE CON 7 PUNTAS DE 1/4" C

L mm	PCS.	COD.	€ cad./each
195	1	65006055	24,400



PH1 1pc.	PH2 1pc.	PH3 1pc.	PZ1 1pc.	PZ2 1pc.	4 1pc.	5 1pc.





# 4 UTENSILI MANUALI

MANUAL TOOLS  
OUTILS À MAIN  
UTENSILIOS MANUALES

**65006**

## ASSORTIMENTI LAME DOPPIE CON CRICCHETTO

ASSORTIMENTO 12 PCS LAME DOPPIE DI PRECISIONE CON CRICCHETTO REVERSIBILE E TELESCOPICO  
12 PCS DOUBLE PRECISION SCREWDRIVER BLADE SET WITH REVERSIBLE TELESCOPIC RATCHET  
JEU DE 12 PCS LAMES DOUBLES DE PRECISION AVEC CLIQUET REVERSIBLE ET TELESCOPIQUE  
JUEGO DE 12 PCS PUNTAS DOBLE DE PRECISION CON CARRACA REVERSIBLE Y TELESCOPICA

**NEW!**

12  
pcs.

COD. **65006042**

€ 41,400



2-PH00 1pc.	3-PH0 1pc.	4-PH1 1pc.	1,5-3 1pc.	2-3,5 1pc.	2,5-4 1pc.
4 1pc.	5 1pc.	5,5 1pc.	7 1pc.	8 1pc.	

INCLUSO / INCLUDED  
INCLUDE / INCLUIDO

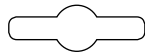

EURO-HOLE

105 X 35 X 220 mm

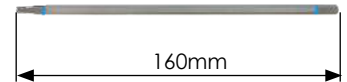



**65006**

## ASSORTIMENTI LAME DOPPIE CON CRICCHETTO

ASSORTIMENTO 9 PCS LAME DOPPIE CON CRICCHETTO REVERSIBILE E TELESCOPICO  
9 PCS DOUBLE SCREWDRIVER BLADE SET WITH REVERSIBLE TELESCOPIC RATCHET  
JEU DE 9 PCS LAMES DOUBLES AVEC CLIQUET REVERSIBLE ET TELESCOPIQUE  
JUEGO DE 9 PCS PUNTAS DOBLE CON CARRACA REVERSIBLE Y TELESCOPICA

**NEW!**

9  
pcs.

COD. **65006041**

€ 43,200



 PH1-PH2 1pc.	 PZ1-PZ2 1pc.	 5-5 1pc.	 6-6 1pc.
 4-6 1pc.	 5-7 1pc.	 TX20-TX25 1pc.	 TX30-TX40 1pc.

INCLUSO / INCLUDED  
INCLUDE / INCLUIDO



120 X 60 X 260 mm

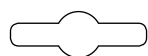

EURO-HOLE



4





# 4 UTENSILI MANUALI

MANUAL TOOLS  
OUTILS À MAIN  
UTENSILIOS MANUALES

**65014**

## CRICCHETTO UNIVERSALE PER MANDRINI A CREMAGLIERA

CRICCHETTO UNIVERSALE PER MANDRINI A CREMAGLIERA  
UNIVERSAL RATCHET FOR DRILL CHUCKS WITH KEY  
CLIQUET UNIVERSAL POUR MANDRINS A CLÉ  
CARRACA UNIVERSAL PARA PORTABROCAS CON LLAVE

**NEW!**

1/4"

72T

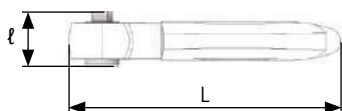

L mm	PCS.	COD.	€ cad./each
112	1	65014010	19,000



**65014**

## CHIAVI PER CENTRALINE QUADRI CASSETTE ACQUA E GAS

CHIAVE CROMATA CON INSERTO DOPPIO ED ADATTATORE  
CHROME WRENCH WITH DOUBLE BIT AND ADAPTER  
CLÉ CHROMÉE AVEC DOUBLE EMBOUT ET ADAPTATEUR  
LLAVE CROMADA CON PUNTA DOBLE Y ADAPTADOR



EURO-HOLE



105 X 180 mm

COD. **65014001**

€ 6,430



INCLUSO / INCLUDED / INCLUDE / INCLUIDO



PH2



1,2x6





# 65015 PUNZONI NUMERICI E ALFABETICI

ASSORTIMENTI PUNZONI ALFABETICI E NUMERICI CARATTERI A FILO  
ALPHABETICAL AND NUMERICAL PUNCHES SET WIRED CHARACTERS  
JEU DE POINÇONS ALPHABÉTIQUES ET NUMÉRIQUES CARACTÈRES AU RAS  
JUEGO DE PUNZONES DE LETRAS Y NUMÉRICOS CON CARACTERES A RAS



9  
pcs.

Gr.	L mm	B mm	COD.	€ cad./each
<b>2</b>	60	6,4	65015000	11,100
<b>3</b>	60	6,4	65015001	11,100
<b>4</b>	60	6,4	65015003	11,600
<b>5</b>	60	8	65015005	15,600
<b>6</b>	67	9,5	65015007	19,100
<b>8</b>	75	11,2	65015010	31,200
<b>10</b>	70	12,9	65015012	39,100



27  
pcs.

Gr.	L mm	B mm	COD.	€ cad./each
<b>2</b>	60	6,4	65015099	32,900
<b>3</b>	60	6,4	65015100	32,900
<b>4</b>	60	6,4	65015103	34,700
<b>5</b>	60	8	65015105	46,200
<b>6</b>	67	9,5	65015107	62,300
<b>8</b>	75	11,2	65015110	95,800
<b>10</b>	70	12,9	65015112	121,900

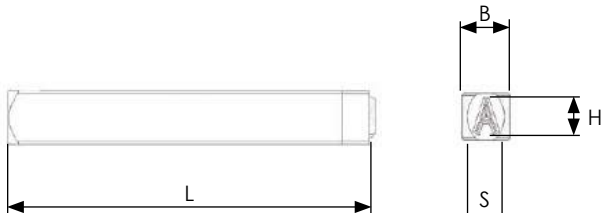

## DIMENSIONI | dimensions • dimensions • medidas

Gr.	L mm	B mm	HxS
<b>2 (5/64")</b>	60	6,4	2,3x1,6
<b>3 (1/8")</b>	60	6,4	3,2x2
<b>4 (5/32")</b>	60	6,4	4x2,9
<b>5 (3/16")</b>	60	8	4,8x3,4
<b>6 (1/4")</b>	67	9,5	6,3x3,8
<b>8 (5/16")</b>	75	11,2	7,9x5
<b>10 (3/8")</b>	70	12,9	9,6x6,6





# 4 UTENSILI MANUALI

MANUAL TOOLS  
OUTILS À MAIN  
UTENSILIOS MANUALES

**65031**

## CHIAVI MASCHIO ESAGONO CORTE

CHIAVI MASCHIO PIEGATE ESAGONALI  
HEXAGONAL MALE WRENCHES  
CLÉS MÂLES À PIPE HEXAGONALES  
LLAVES MACHO DOBLADAS HEXAGONALES

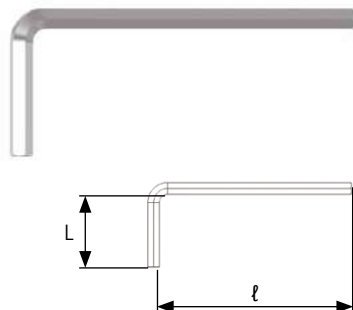

**EASYPACK** | sacchetto PVC con Euro-hole • PVC bags with Euro-hole

Ø	L mm	l mm	PCS.	COD.	€ cad./each
1,5	11	45	10	65031005	0,210
2	15	50	10	65031010	0,230
2,5	17	55	10	65031015	0,250
3	19,5	60	10	65031020	0,310
4	23	65	10	65031025	0,340
5	26	72	10	65031030	0,720
6	32	90	10	65031035	0,920
8	36	100	10	65031040	1,290
10	40	112	10	65031045	2,030
13	16	142	10	65031060	5,960
17	80	177	10	65031080	9,930
19	89	199	10	65031090	13,900
22	100	216	10	65031110	23,900

**65034**

## CHIAVI MASCHIO ESAGONO SFERICO CORTE

CHIAVI MASCHIO PIEGATE ESAGONALI TESTA SFERICA  
BALL-HEAD HEXAGONAL MALE WRENCHES  
CLÉS MÂLES À PIPE HEXAGONALES À TÊTE SPHÉRIQUE  
LLAVES MACHO DOBLADAS HEXAGONALES CON CABEZA ESFÉRICA

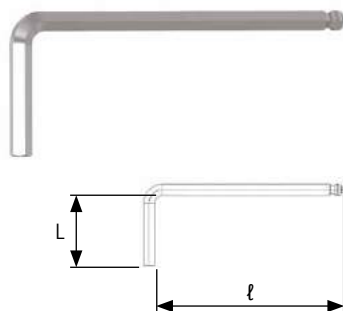

**EASYPACK** | sacchetto PVC con Euro-hole • PVC bags with Euro-hole

Ø	L mm	l mm	PCS.	COD.	€ cad./each
1,5	11	45	10	65034005	0,300
2	15	50	10	65034010	0,330
2,5	17	55	10	65034015	0,350
3	19,5	60	10	65034020	0,410
4	23	65	10	65034025	0,480
5	26	72	10	65034030	0,880
6	32	90	10	65034035	1,080
8	36	100	10	65034040	1,490
10	40	112	10	65034045	2,170



**65041**

**CHIAVI MASCHIO TX  
CORTE**

CHIAVI MASCHIO PIEGATE PER VITI TORX®  
MALE WRENCHES FOR TORX® SCREWS  
CLÉS MÂLES À PIPE POUR VIS TORX®  
LLAVES MACHO DOBLADAS PARA TORNILLOS TORX®

**EASYPACK** | sacchetto PVC con Euro-hole • PVC bags with Euro-hole

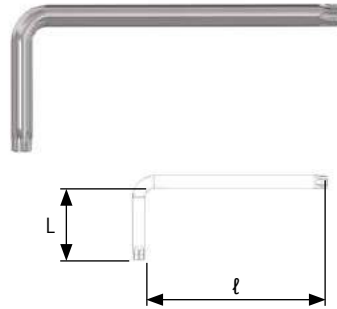

	L mm	ℓ mm	PCS.	COD.	€ cad./each
<b>TX10</b>	13,5	45	10	65041025	0,340
<b>TX15</b>	15	50	10	65041030	0,550
<b>TX20</b>	18	56	10	65041035	0,680
<b>TX25</b>	20	63	10	65041040	0,810
<b>TX27</b>	25	70	10	65041045	0,950
<b>TX30</b>	28	80	10	65041050	1,120
<b>TX40</b>	32	90	10	65041055	1,360
<b>TX45</b>	36	100	10	65041060	1,490
<b>TX50</b>	40	112	10	65041065	1,760

**65044**

**CHIAVI MASCHIO TXH  
CORTE**

CHIAVI MASCHIO PIEGATE PER VITI TORX® CON FORO  
MALE WRENCHES FOR TORX® SCREWS WITH HOLE  
CLÉS MÂLES À PIPE POUR VIS TORX® AVEC TROU  
LLAVES MACHO DOBLADAS PARA TORNILLOS TORX® CON ORIFICIO

**EASYPACK** | sacchetto PVC con Euro-hole • PVC bags with Euro-hole

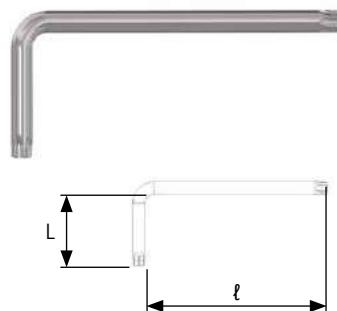

	L mm	ℓ mm	PCS.	COD.	€ cad./each
<b>TXH10</b>	13,5	45	10	65044025	0,340
<b>TXH15</b>	15	50	10	65044030	0,550
<b>TXH20</b>	18	56	10	65044035	0,680
<b>TXH25</b>	20	63	10	65044040	0,810
<b>TXH27</b>	25	70	10	65044045	0,950
<b>TXH30</b>	28	80	10	65044050	1,120
<b>TXH40</b>	32	90	10	65044055	1,360
<b>TXH45</b>	36	100	10	65044060	1,490
<b>TXH50</b>	40	112	10	65044065	1,760





# 4 UTENSILI MANUALI

MANUAL TOOLS  
OUTILS À MAIN  
UTENSILIOS MANUALES

## 65032 CHIAVI MASCHIO ESAGONO LUNGHE

CHIAVI MASCHIO PIEGATE ESAGONALI TIPO LUNGO  
LONG HEXAGONAL MALE WRENCHES  
CLÉS MÂLES À PIPE HEXAGONALES LONGUES  
LLAVES MACHO DOBLADAS HEXAGONALES LARGAS

**NEW!**

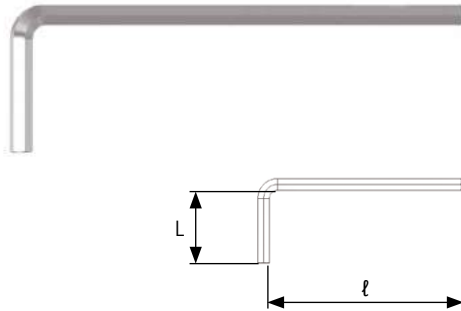

**EASYPACK** | sacchetto PVC con Euro-hole • PVC bags with Euro-hole

Ø	L mm	l mm	PCS.	COD.	€ cad./each
1,5	14	72	10	65032005	0,170
2	15	80	10	65032010	0,190
2,5	17	86	10	65032015	0,220
3	19	94	10	65032020	0,270
4	21	102	10	65032025	0,340
5	26	115	10	65032030	0,720
6	30	134	10	65032035	0,920
8	32	152	10	65032040	1,290
10	38	170	10	65032045	2,030

## 65035 CHIAVI MASCHIO ESAGONO SFERICO LUNGHE

CHIAVI MASCHIO PIEGATE ESAGONALI TESTA SFERICA TIPO LUNGO  
LONG BALL HEAD HEXAGONAL MALE WRENCHES  
CLÉS MÂLES À PIPE HEXAGONALES À TÊTE SPHÉRIQUE LONGUES  
LLAVES MACHO DOBLADAS HEXAGONALES CON CABEZA ESFÉRICA LARGAS

**NEW!**

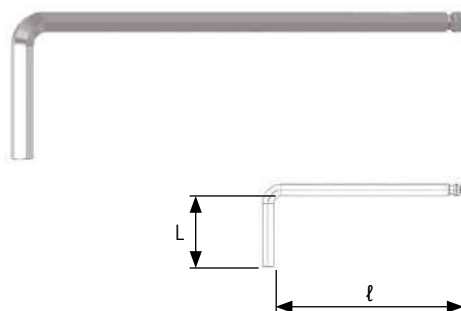

**EASYPACK** | sacchetto PVC con Euro-hole • PVC bags with Euro-hole

Ø	L mm	l mm	PCS.	COD.	€ cad./each
1,5	14	72	10	65035005	0,300
2	15	80	10	65035010	0,330
2,5	17	86	10	65035015	0,390
3	19	94	10	65035020	0,480
4	21	102	10	65035025	0,880
5	26	115	10	65035030	1,080
6	30	134	10	65035035	1,620
8	32	152	10	65035040	2,030
10	39	170	10	65035045	3,110



## 65042 CHIAVI MASCHIO TX LUNGHE

CHIAVI MASCHIO PIEGATE TX TIPO LUNGO  
LONG TX MALE WRENCHES  
CLÉS MÂLES À PIPE POUR VIS TORX® LUNGUES  
LLAVES MACHO DOBLADAS PARA TORNILLOS TORX® LARGAS

**NEW!**

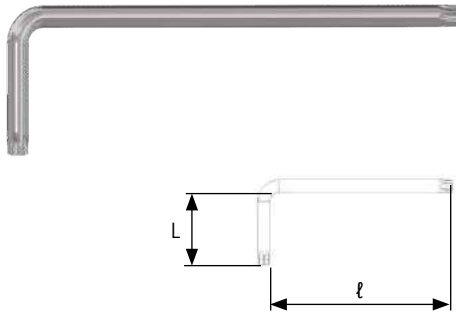

**EASYPACK** | sacchetto PVC con Euro-hole • PVC bags with Euro-hole

	L mm	ℓ mm	PCS.	COD.	€ cad./each
<b>TX10</b>	17	86	10	65042025	0,550
<b>TX15</b>	19	90	10	65042030	0,550
<b>TX20</b>	20	95	10	65042035	0,710
<b>TX25</b>	21	99	10	65042040	0,710
<b>TX27</b>	22	104	10	65042045	0,790
<b>TX30</b>	25	114	10	65042050	1,020
<b>TX40</b>	27	124	10	65042055	1,420
<b>TX45</b>	29	135	10	65042060	2,830
<b>TX50</b>	34	150	10	65042065	4,710

## 65045 CHIAVI MASCHIO TXH LUNGHE

CHIAVI MASCHIO PIEGATE TXH TIPO LUNGO  
LONG TXH WITH HOLE MALE WRENCHES  
CLÉS MÂLES À PIPE POUR VIS TORX® AVEC TROU LONGUES  
LLAVES MACHO DOBLADAS PARA TORNILLOS TORX® CON ORIFICIO LARGAS

**NEW!**

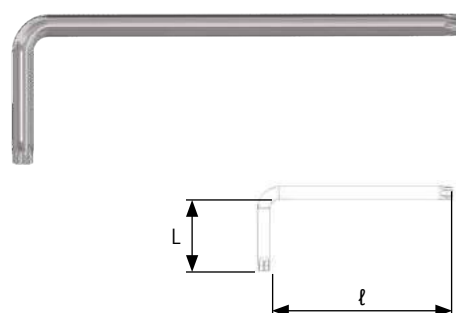

**EASYPACK** | sacchetto PVC con Euro-hole • PVC bags with Euro-hole

	L mm	ℓ mm	PCS.	COD.	€ cad./each
<b>TXH10</b>	17	86	10	65045025	0,550
<b>TXH15</b>	19	90	10	65045030	0,550
<b>TXH20</b>	20	95	10	65045035	0,710
<b>TXH25</b>	21	99	10	65045040	0,710
<b>TXH27</b>	22	104	10	65045045	0,790
<b>TXH30</b>	25	114	10	65045050	1,020
<b>TXH40</b>	27	124	10	65045055	1,420
<b>TXH45</b>	29	135	10	65045060	2,830
<b>TXH50</b>	34	150	10	65045065	4,710





# 4 UTENSILI MANUALI

MANUAL TOOLS  
OUTILS À MAIN  
UTENSILIOS MANUALES

**65033**

## CHIAVI MASCHIO ESAGONO EXTRA LUNGHE

CHIAVI MASCHIO PIEGATE ESAGONALI TIPO EXTRA-LUNGO  
EXTRA-LONG HEXAGONAL MALE WRENCHES  
CLÉS MÂLES À PIPE HEXAGONALES EXTRA LONGUES  
LLAVES MACHO DOBLADAS HEXAGONALES TIPO EXTRA-LARGO

**EASYPACK** | sacchetto PVC con Euro-hole • PVC bags with Euro-hole

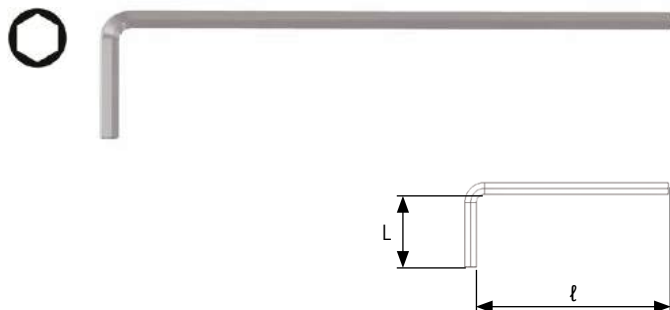

Ø	L mm	ℓ mm	PCS.	COD.	€ cad./each
<b>1,5</b>	14	90	10	65033005	<b>0,370</b>
<b>2</b>	16	98	10	65033010	<b>0,430</b>
<b>2,5</b>	18	110	10	65033015	<b>0,490</b>
<b>3</b>	20	125	10	65033020	<b>0,550</b>
<b>4</b>	24	138	10	65033025	<b>0,780</b>
<b>5</b>	28	157	10	65033030	<b>1,150</b>
<b>6</b>	31	178	10	65033035	<b>1,810</b>
<b>8</b>	35	196	10	65033040	<b>2,160</b>
<b>10</b>	40	220	10	65033045	<b>3,130</b>

**65036**

## CHIAVI MASCHIO ESAGONO SFERICO EXTRA LUNGHE

CHIAVI MASCHIO PIEGATE ESAGONALI TESTA SFERICA TIPO EXTRA-LUNGO  
EXTRA-LONG BALL HEAD HEXAGONAL MALE WRENCHES  
CLÉS MÂLES À PIPE HEXAGONALES À TÊTE SPHÉRIQUE EXTRA LONGUES  
LLAVES MACHO DOBLADAS HEXAGONALES CON CABEZA ESFÉRICA TIPO EXTRA-LARGO

**EASYPACK** | sacchetto PVC con Euro-hole • PVC bags with Euro-hole

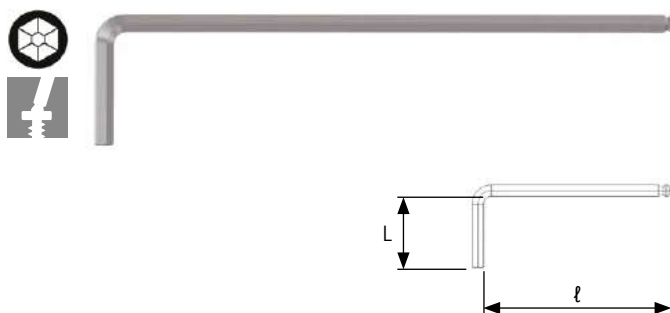

Ø	L mm	ℓ mm	PCS.	COD.	€ cad./each
<b>1,5</b>	14	90	10	65036005	<b>0,550</b>
<b>2</b>	16	98	10	65036010	<b>0,610</b>
<b>2,5</b>	18	110	10	65036015	<b>0,680</b>
<b>3</b>	20	125	10	65036020	<b>0,750</b>
<b>4</b>	24	138	10	65036025	<b>0,950</b>
<b>5</b>	28	157	10	65036030	<b>1,360</b>
<b>6</b>	31	178	10	65036035	<b>2,030</b>
<b>8</b>	35	196	10	65036040	<b>2,430</b>
<b>10</b>	40	220	10	65036045	<b>3,650</b>



## 65043 CHIAVI MASCHIO TX EXTRA LUNGHE

CHIAVI MASCHIO PIEGATE PER VITI TORX® TIPO EXTRA-LUNGO  
EXTRA-LONG MALE WRENCHES FOR TORX® SCREWS  
CLÉS MÂLES À PIPE POUR VIS TORX® EXTRA LONGUES  
LLAVES MACHO DOBLADAS PARA TORNILLOS TORX® TIPO EXTRA-LARGO

**EASYPACK** | sacchetto PVC con Euro-hole • PVC bags with Euro-hole

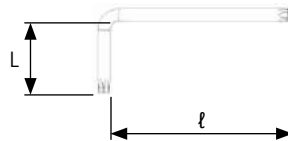

	L mm	ℓ mm	PCS.	COD.	€ cad./each
<b>TX10</b>	16	90	10	65043005	0,550
<b>TX15</b>	17	102	10	65043010	0,680
<b>TX20</b>	18	111	10	65043015	0,920
<b>TX25</b>	20	126	10	65043020	1,080
<b>TX27</b>	25	142	10	65043025	1,290
<b>TX30</b>	28	160	10	65043030	1,490
<b>TX40</b>	33	174	10	65043035	1,760
<b>TX45</b>	36	195	10	65043040	2,300
<b>TX50</b>	40	218	10	65043045	2,570

## 65046 CHIAVI MASCHIO TXH EXTRA LUNGHE

CHIAVI MASCHIO PIEGATE PER VITI TORX® CON FORO TIPO EXTRA-LUNGO  
EXTRA-LONG MALE WRENCHES FOR TORX® SCREWS WITH HOLE  
CLÉS MÂLES À PIPE POUR VIS TORX® AVEC TROU EXTRA LONGUE  
LLAVES MACHO DOBLADAS PARA TORNILLOS TORX® CON ORIFICIO TIPO EXTRA-LARGO

**EASYPACK** | sacchetto PVC con Euro-hole • PVC bags with Euro-hole

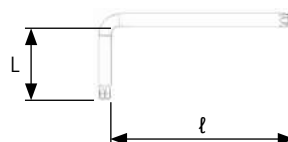

	L mm	ℓ mm	PCS.	COD.	€ cad./each
<b>TXH10</b>	16	90	10	65046005	0,610
<b>TXH15</b>	17	102	10	65046010	0,750
<b>TXH20</b>	18	111	10	65046015	0,920
<b>TXH25</b>	20	126	10	65046020	1,020
<b>TXH27</b>	25	142	10	65046025	1,360
<b>TXH30</b>	28	160	10	65046030	1,560
<b>TXH40</b>	33	174	10	65046035	1,830
<b>TXH45</b>	36	195	10	65046040	2,370
<b>TXH50</b>	40	218	10	65046045	2,780





# 4 UTENSILI MANUALI

MANUAL TOOLS  
OUTILS À MAIN  
UTENSILIOS MANUALES

## 65101 SET CHIAVI CORTE

SERIE 9 PCS. CHIAVI MASCHIO PIEGATE  
SERIES 9 MALE WRENCHES  
JEU 9 PIÈCES CLÉS MÂLES À PIPE  
JUEGO DE 9 PIEZAS DE LLAVES MACHO DOBLADAS



9  
pcs.

COD. **65101001**  
€ 6,400

65031 

1,5	2	2,5	3	4	5	6	8	10
1pc.	1pc.	1pc.	1pc.	1pc.	1pc.	1pc.	1pc.	1pc.

COD. **65101011**  
€ 6,800

65034 

1,5	2	2,5	3	4	5	6	8	10
1pc.	1pc.	1pc.	1pc.	1pc.	1pc.	1pc.	1pc.	1pc.

COD. **65101031**  
€ 6,900

65041 

TX10	TX15	TX20	TX25	TX27	TX30	TX40	TX45	TX50
1pc.	1pc.	1pc.	1pc.	1pc.	1pc.	1pc.	1pc.	1pc.

COD. **65101041**  
€ 7,600

65044 

TXH10	TXH15	TXH20	TXH25	TXH27	TXH30	TXH40	TXH45	TXH50
1pc.	1pc.	1pc.	1pc.	1pc.	1pc.	1pc.	1pc.	1pc.

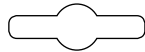

EURO-HOLE

950 X 180 mm





# 65101 SET CHIAVI LUNGHE

SET 9 PCS CHIAVI MASCHIO PIEGATE TIPO LUNGO  
 9 PCS LONG MALE WRENCHES SET  
 JEU 9 PIÈCES CLÉS MÂLES À PIPE  
 JUEGO DE 9 PIEZAS DE LLAVES MACHO DOBLADAS

**NEW!**

9  
pcs.



COD. **65101002**  
€ 7,600

65032

1,5	2	2,5	3	4	5	6	8	10
1pc.	1pc.	1pc.	1pc.	1pc.	1pc.	1pc.	1pc.	1pc.

COD. **65101012**  
€ 8,200

65035

1,5	2	2,5	3	4	5	6	8	10
1pc.	1pc.	1pc.	1pc.	1pc.	1pc.	1pc.	1pc.	1pc.

COD. **65101032**  
€ 8,800

65042

TX10	TX15	TX20	TX25	TX27	TX30	TX40	TX45	TX50
1pc.	1pc.	1pc.	1pc.	1pc.	1pc.	1pc.	1pc.	1pc.

COD. **65101042**  
€ 9,800

65045

TXH10	TXH15	TXH20	TXH25	TXH27	TXH30	TXH40	TXH45	TXH50
1pc.	1pc.	1pc.	1pc.	1pc.	1pc.	1pc.	1pc.	1pc.



EURO-HOLE





# 4 UTENSILI MANUALI

MANUAL TOOLS  
OUTILS À MAIN  
UTENSILIOS MANUALES

## 65101 SET CHIAVI MASCHIO TIPO LUNGO

SERIE 8 PCS. CHIAVI MASCHIO PIEGATE IN ASTUCCIO UTILIZZABILE COME MANICO  
SERIES 8 MALE WRENCHES IN CASE THAT CAN BE USED AS A HANDLE  
JEU 8 PIÈCES CLÉS MÂLES À PIPE DANS UNE BOÎTE POUVANT ÊTRE UTILISÉE COMME UN MANCHE  
JUEGO DE 8 PIEZAS DE LLAVES MACHO DOBLADAS EN ESTUCHE UTILIZABLE COMO MANGO



8  
pcs.

COD. **65101015**  
€ 11,000

		L mm	ℓ mm
	2	16	85
	2,5	18	92
	3	20	100
	4	25	110
	5	28	120
	6	32	140
	8	36	160
	10	40	180

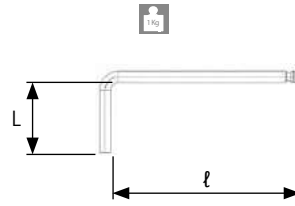

COD. **65101035**  
€ 11,400

		L mm	ℓ mm
	TX10	17	86
	TX15	18	90
	TX20	19	95
	TX25	20	100
	TX30	21	105
	TX40	26	124
	TX45	29	133
	TX50	32	152

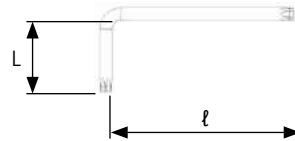

EURO-HOLE

95 X 240 mm

COD. **65101045**  
€ 11,800

		L mm	ℓ mm
	TXH10	17	86
	TXH15	18	90
	TXH20	19	95
	TXH25	20	100
	TXH30	21	105
	TXH40	26	124
	TXH45	29	133
	TXH50	32	152

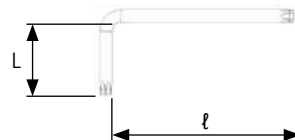

### FOCUS ON



La custodia, dotata di gancio di sicurezza, diventa anche una pratica impugnatura per manovrare ogni chiave in modo più confortevole.

The housing, equipped with safety hook, also becomes a practical handle to comfortably manoeuvre each wrench.

L'étui, équipé d'un crochet de sécurité, devient également une poignée pratique pour manoeuvrer chaque clé de façon plus confortable.

El estuche, provisto de enganche de seguridad, se convierte también en un práctico mango para poder usar cada llave de forma más cómoda.





# 65101 SET CHIAVI EXTRA LUNGHE

SERIE 9 PCS. CHIAVI MASCHIO PIEGATE TIPO EXTRA-LUNGO  
 EXTRA-LONG SERIES 9 MALE WRENCHES  
 JEU 9 PIÈCES CLÉS MÂLES À PIPE EXTRA LONGUE  
 JUEGO DE 9 PIEZAS DE LLAVES MACHO DOBLADAS TIPO EXTRA-LARGO



9 pcs.

COD. **65101003**  
 € 9,500

65033

1,5 1pc.	2 1pc.	2,5 1pc.	3 1pc.	4 1pc.	5 1pc.	6 1pc.	8 1pc.	10 1pc.
-------------	-----------	-------------	-----------	-----------	-----------	-----------	-----------	------------

COD. **65101013**  
 € 10,600

65036

1,5 1pc.	2 1pc.	2,5 1pc.	3 1pc.	4 1pc.	5 1pc.	6 1pc.	8 1pc.	10 1pc.
-------------	-----------	-------------	-----------	-----------	-----------	-----------	-----------	------------

COD. **65101033**  
 € 11,200

65043

TX10 1pc.	TX15 1pc.	TX20 1pc.	TX25 1pc.	TX27 1pc.	TX30 1pc.	TX40 1pc.	TX45 1pc.	TX50 1pc.
--------------	--------------	--------------	--------------	--------------	--------------	--------------	--------------	--------------

COD. **65101043**  
 € 12,800

65046

TXH10 1pc.	TXH15 1pc.	TXH20 1pc.	TXH25 1pc.	TXH27 1pc.	TXH30 1pc.	TXH40 1pc.	TXH45 1pc.	TXH50 1pc.
---------------	---------------	---------------	---------------	---------------	---------------	---------------	---------------	---------------

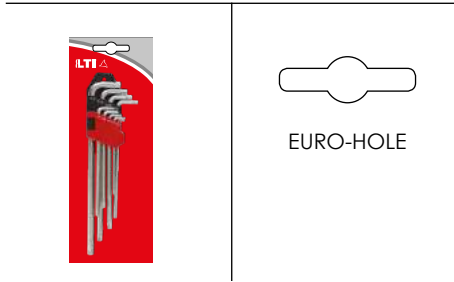

EURO-HOLE

950 X 310 mm





# 4 UTENSILI MANUALI

MANUAL TOOLS  
OUTILS À MAIN  
UTENSILIOS MANUALES

**65101**

## SET CHIAVI MASCHIO PUNTA MAGNETICA

SERIE 9 PCS. CHIAVI MASCHIO PIEGATE EXTRA-LUNGHE COLORATE PUNTA MAGNETICA  
SERIES 9 EXTRA-LONG COLOURED MALE WRENCHES WITH MAGNETIC TIP  
JEU 9 PIÈCES CLÉS MÂLES À PIPE EXTRA-LONGUES COLORÉES TÊTE AIMANTÉE  
JUEGO DE 9 PIEZAS DE LLAVES MACHO DOBLADAS EXTRA-LARGAS COLOREADAS CON PUNTA MAGNÉTICA



9  
pcs.

COD. **65101014**

€ 29,000

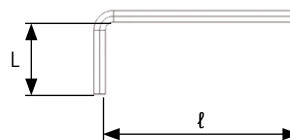

	L mm	l mm
1,5	14	90
2	16	100
2,5	18	112
3	20	126
4	25	142
5	28	160
6	32	180
8	36	200
10	40	224



EURO-HOLE

95 X 310 mm



### FOCUS ON



La testa sferica magnetica consente di frattare la vite in posizione anche in caso di lavori difficili diminuendo il rischio di perdere il fastener.

The spherical magnetic head allows holding the screw in position even during difficult machining, reducing the risk of losing the fastener.

La tête sphérique magnétique permet de retenir la vis dans sa position même en cas de travaux difficiles, en réduisant le risque de perdre la fixation.

El cabezal esférico magnético permite mantener el tornillo en su sitio incluso cuando se realicen trabajos difíciles disminuyendo el riesgo de perder la abrazadera.



# 65101 SET CHIAVI EXTRA-LUNGHE TX PUNTA MAGNETICA

SET 9PZ CHIAVI MASCHIO PIEGATE TX EXTRA-LUNGHE COLORATE PUNTA MAGNETICA  
9 PCS EXTRA LONG TX WRENCHES COLOURED WITH MAGNETIC TIP  
JEU 9 PCS CLES MALES A PIPE TX EXTRA LONGUES COLOREES TETE AIMANTEE  
JUEGO 9 PCS LLAVES MACHOS TX EXTRA LARGAS COLOREADAS CON PUNTA MAGNETICA

**NEW!**



9 pcs.

COD. **65101034**  
€ 33,500

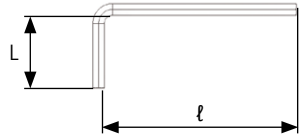

	L mm	l mm
TX10	16	90
TX15	17	102
TX20	18	111
TX25	20	126
TX27	25	142
TX30	28	160
TX40	33	174
TX45	36	195
TX50	40	218

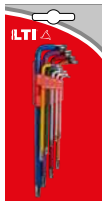

EURO-HOLE

88 X 300 mm



## FOCUS ON



La testa sferica magnetica consente di trattenere la vite in posizione anche in caso di lavori difficoltosi diminuendo il rischio di perdere il fastener.

The spherical magnetic head allows holding the screw in position even during difficult machining, reducing the risk of losing the fastener.

La tête sphérique magnétique permet de retenir la vis dans sa position même en cas de travaux difficiles, en réduisant le risque de perdre la fixation.

El cabezal esférico magnético permite mantener el tornillo en su sitio incluso cuando se realicen trabajos difíciles disminuyendo el riesgo de perder la abrazadera.





# 4 UTENSILI MANUALI

MANUAL TOOLS  
OUTILS À MAIN  
UTENSILIOS MANUALES

## 65101 SET PIEGHEVOLE CHIAVI MASCHIO

SERIE PIEGHEVOLI CHIAVI MASCHIO  
SERIES FOLDING MALE WRENCHES  
JEU PLIABLES CLÉS MÂLES  
JUEGO DE ACCESORIOS QUE SE PUEDEN DOBLAR PARA LLAVES MACHO



7  
pcs.

COD. **65101016**  
€ 7,200



1,5 1pc.	2 1pc.	2,5 1pc.	3 1pc.	4 1pc.	5 1pc.	6 1pc.	8 1pc.
-------------	-----------	-------------	-----------	-----------	-----------	-----------	-----------



EURO-HOLE

170 X 45 X 35 mm

## 65101 SET PIEGHEVOLE CHIAVI MASCHIO

SERIE PIEGHEVOLI CHIAVI MASCHIO  
SERIES FOLDING MALE WRENCHES  
JEU PLIABLES CLÉS MÂLES  
JUEGO DE ACCESORIOS QUE SE PUEDEN DOBLAR PARA LLAVES MACHO



8  
pcs.

COD. **65101036**  
€ 7,300



TX08 1pc.	TX10 1pc.	TX15 1pc.	TX20 1pc.	TX25 1pc.	TX27 1pc.	TX30 1pc.	TX40 1pc.
--------------	--------------	--------------	--------------	--------------	--------------	--------------	--------------



EURO-HOLE

170 X 45 X 35 mm



# 65101 SET PIEGHEVOLE CHIAVI MASCHIO

SERIE PIEGHEVOLI CHIAVI MASCHIO  
SERIES FOLDING MALE WRENCHES  
JEU PLIABLES CLÉS MÂLES  
JUEGO DE ACCESORIOS QUE SE PUEDEN DOBLAR PARA LLAVES MACHO

**NEW!**

7  
pcs.

COD. **65101017**

€ 7,600



1,5 1pc.	2 1pc.	2,5 1pc.	3 1pc.	4 1pc.	5 1pc.	6 1pc.	8 1pc.
-------------	-----------	-------------	-----------	-----------	-----------	-----------	-----------



EURO-HOLE

170 X 45 X 35 mm

4





# 4 UTENSILI MANUALI

MANUAL TOOLS  
OUTILS À MAIN  
UTENSILIOS MANUALES

## 65051 CHIAVI A "T" ESAGONALI

CHIAVI MASCHIO ESAGONALI IMPUGNATURA A "T"  
HEXAGONAL MALE WRENCHES WITH T-SHAPED HANDLE  
CLÉS MÂLES HEXAGONALES POIGNÉE EN "T"  
LLAVES MACHO HEXAGONALES CON MANGO CON FORMA DE "T"

**EASYPACK** | scatola di cartone • cardboard box

**NEW!**

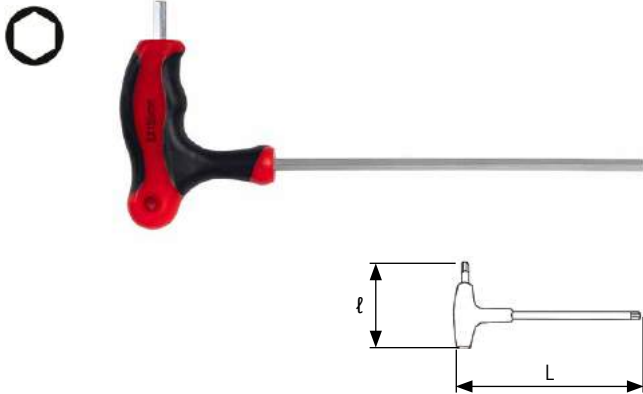

Ø	L mm	l mm	PCS.	COD.	€ cad./each
2	145	65	6	65051005	2,370
2,5	145	67	6	65051010	2,370
3	145	70	6	65051015	2,500
4	210	92	6	65051020	2,710
5	210	92	6	65051025	3,090
6	210	95	6	65051030	3,300
8	280	115	6	65051035	3,970
10	280	117	6	65051040	4,520

Ø	COD.	€ cad./each
2	65051005001	3,620
2,5	65051010001	3,620
3	65051015001	3,750
4	65051020001	3,960
5	65051025001	4,340
6	65051030001	4,550
8	65051035001	5,220
10	65051040001	5,770

**SELPACK**  
1 pc.

## 65052 CHIAVI A "T" ESAGONO SFERICO

CHIAVI MASCHIO ESAGONALI TESTA SFERICA IMPUGNATURA A "T"  
BALL HEAD HEXAGONAL MALE WRENCHES WITH T-SHAPED HANDLE  
CLÉS MÂLES HEXAGONALES À TÊTE SPHÉRIQUE POIGNÉE EN "T"  
LLAVES MACHO HEXAGONALES, CABEZA ESFÉRICA Y MANGO CON FORMA DE "T"

**EASYPACK** | scatola di cartone • cardboard box

**NEW!**

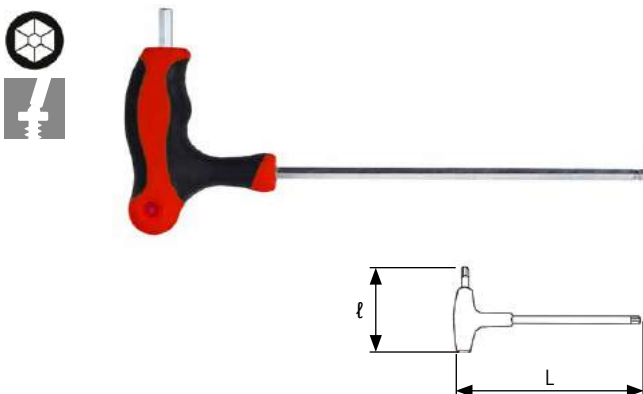

Ø	L mm	l mm	PCS.	COD.	€ cad./each
2	145	65	6	65052005	2,500
2,5	145	67	6	65052010	2,500
3	145	70	6	65052015	2,620
4	210	92	6	65052020	2,860
5	210	92	6	65052025	3,240
6	210	95	6	65052030	3,470
8	280	115	6	65052035	4,180
10	280	117	6	65052040	4,760

Ø	COD.	€ cad./each
2	65052005001	3,750
2,5	65052010001	3,750
3	65052015001	3,870
4	65052020001	4,110
5	65052025001	4,490
6	65052030001	4,720
8	65052035001	5,430
10	65052040001	6,010

**SELPACK**  
1 pc.





# 65053 CHIAVI A "T" A TX

CHIAVI MASCHIO PER VITI TORX® IMPUGNATURA A "T"  
 MALE WRENCHES FOR TORX® SCREWS WITH T-SHAPED HANDLE  
 CLÉS MÂLES POUR VIS TORX® POIGNÉE EN "T"  
 LLAVES MACHO PARA TORNILLOS TORX® CON MANGO CON FORMA DE "T"

**EASYPACK** | scatola di cartone • cardboard box

**NEW!**

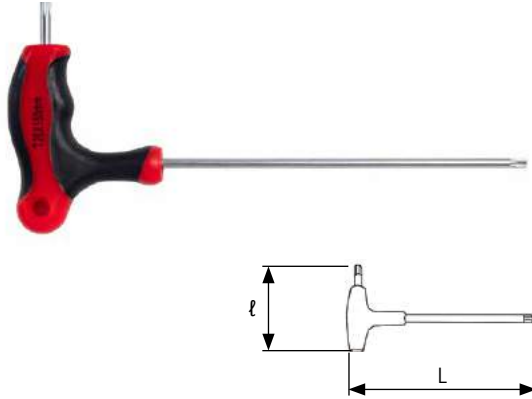

	L mm	l mm	PCS.	COD.	€ cad./each
<b>TX06</b>	145	65	6	65053005	2,220
<b>TX07</b>	145	65	6	65053010	2,220
<b>TX08</b>	145	65	6	65053015	2,220
<b>TX09</b>	145	65	6	65053020	2,220
<b>TX10</b>	145	67	6	65053025	2,580
<b>TX15</b>	145	67	6	65053030	2,710
<b>TX20</b>	145	67	6	65053035	2,830
<b>TX25</b>	210	93	6	65053040	3,090
<b>TX27</b>	210	93	6	65053045	3,550
<b>TX30</b>	210	95	6	65053050	3,760
<b>TX40</b>	280	115	6	65053055	4,610
<b>TX45</b>	280	115	6	65053060	4,940



	COD.	€ cad./each
<b>TX06</b>	65053005001	3,470
<b>TX07</b>	65053010001	3,470
<b>TX08</b>	65053015001	3,470
<b>TX09</b>	65053020001	3,470
<b>TX10</b>	65053025001	3,830
<b>TX15</b>	65053030001	3,960
<b>TX20</b>	65053035001	4,080
<b>TX25</b>	65053040001	4,340
<b>TX27</b>	65053045001	4,800
<b>TX30</b>	65053050001	5,010
<b>TX40</b>	65053055001	5,860
<b>TX45</b>	65053060001	6,190



**SELPACK**  
1 pc.





# 4 UTENSILI MANUALI

MANUAL TOOLS  
OUTILS À MAIN  
UTENSILIOS MANUALES

**65101** SET CHIAVI A "T"

SERIE 8 PCS. CHIAVI MASCHIO IMPUGNATURA A "T"  
SERIES 8 MALE WRENCHES WITH T-SHAPED HANDLE  
JEU 8 PIÈCES CLÉS MÂLES POIGNÉE EN "T"  
JUEGO DE 8 PIEZAS DE LLAVES MACHO CON MANGO CON FORMA DE "T"

**NEW!**

8  
pcs.



290 X 90 X 120 mm

COD. **65101100**  
€ 34,000

Ø	L mm	ℓ mm
2	145	65
2,5	145	67
3	145	70
4	210	92
5	210	92
6	210	95
8	280	115
10	280	117

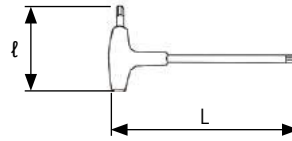

COD. **65101105**  
€ 33,200

Ø	L mm	ℓ mm
2	145	65
2,5	145	67
3	145	70
4	210	92
5	210	92
6	210	95
8	280	115
10	280	117

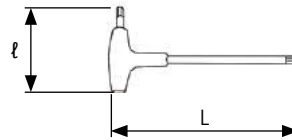

COD. **65101110**  
€ 34,000

Ø	L mm	ℓ mm
TX10	145	67
TX15	145	67
TX20	145	67
TX25	210	93
TX27	210	93
TX30	210	95
TX40	280	115
TX45	280	115

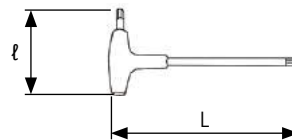

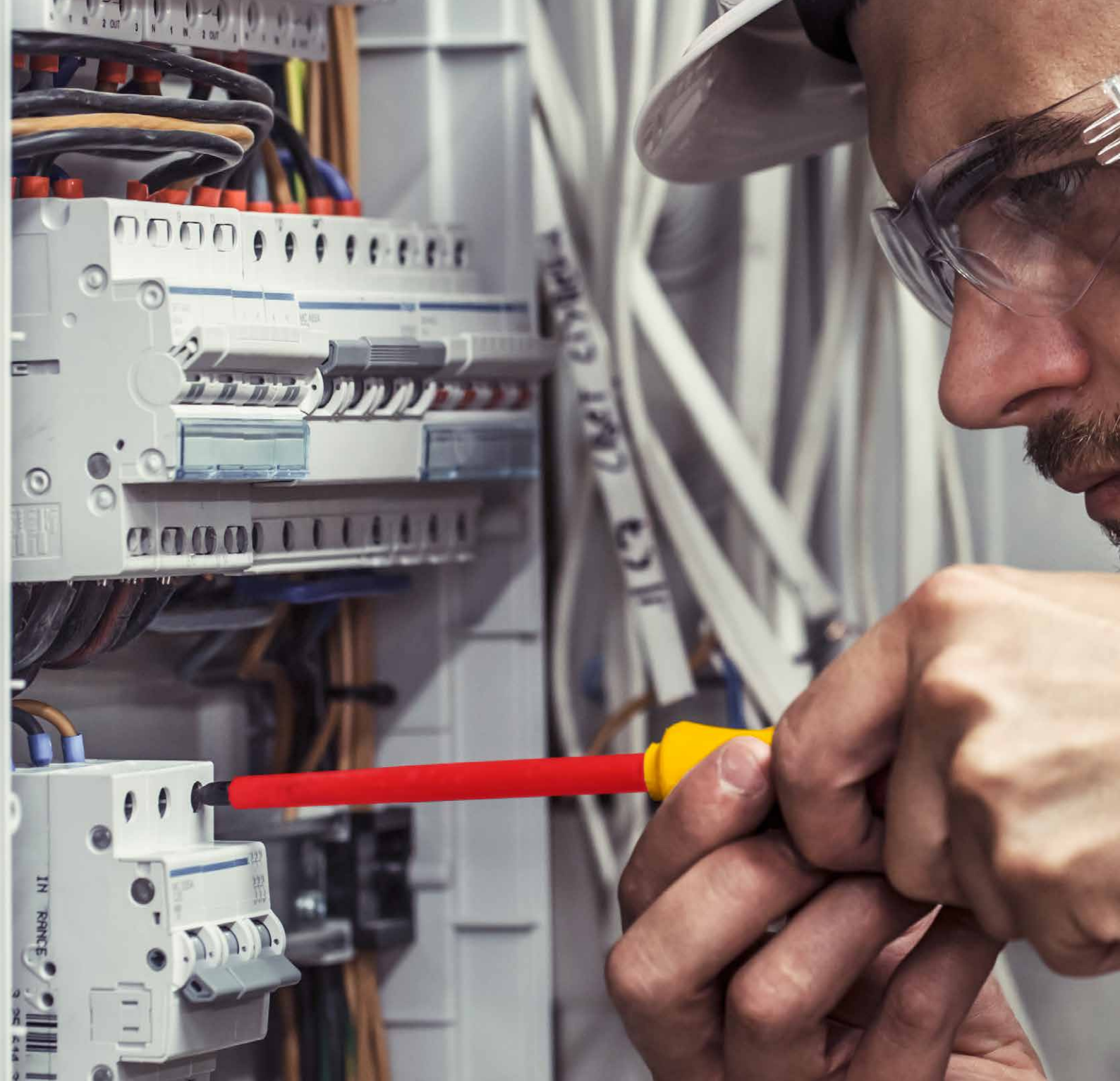

*Installazione di un quadro elettrico.  
Installation of an electrical panel.  
Installation d'un tableau électrique.  
Instalación de un cuadro eléctrico.*

# 4 UTENSILI MANUALI

MANUAL TOOLS  
OUTILS À MAIN  
UTENSILIOS MANUALES

## 65201 CHIAVI COMBinate

CHIAVI COMBinate FINITURA SEMILUCIDA  
COMBINATION WRENCHES MATT FINISH  
CLÉS MIXTES FINITION SEMI-BRILLANTE  
LLAVES COMBINADAS ACABADO SEMI-BRILLANTE

**EASYPACK** | scatola di cartone • cardboard box

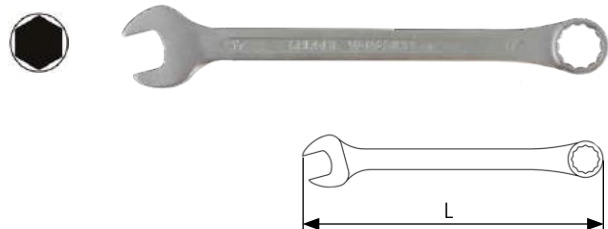

⊙	L mm	PCS.	COD.	€ cad./each
6	95	6	65201005	1,130
7	105	6	65201010	1,170
8	120	6	65201015	1,210
9	130	6	65201020	1,250
10	140	6	65201025	1,320
11	150	6	65201030	1,470
12	160	6	65201035	1,620
13	170	6	65201040	1,730
14	180	6	65201045	1,810
15	190	6	65201050	2,150
16	200	6	65201055	2,300
17	210	6	65201060	2,640
18	220	6	65201065	2,870
19	230	6	65201070	3,140
20	245	6	65201075	3,940
21	255	6	65201080	3,970
22	260	6	65201085	4,120
23	275	6	65201090	5,020
24	285	6	65201095	5,370
25	295	6	65201100	6,650
26	310	6	65201105	6,850
27	320	6	65201110	7,150
28	330	6	65201115	8,850
29	340	6	65201120	8,980
30	340	6	65201125	9,240
32	360	6	65201130	9,490

⊙	COD.	€ box
6	65201005001	2,130
7	65201010001	2,170
8	65201015001	2,210
9	65201020001	2,250
10	65201025001	2,320
11	65201030001	2,470
12	65201035001	2,620
13	65201040001	2,730
14	65201045001	2,810
15	65201050001	3,150
16	65201055001	3,300
17	65201060001	3,640
18	65201065001	3,870
19	65201070001	4,140
20	65201075001	4,940
21	65201080001	4,970
22	65201085001	5,120
23	65201090001	6,020
24	65201095001	6,370
25	65201100001	7,650
26	65201105001	7,850
27	65201110001	8,150
28	65201115001	9,850
29	65201120001	9,980
30	65201125001	10,240
32	65201130001	10,490



SELPACK  
1 pc.

## 65301 SET CHIAVI COMBinate

SERIE 12 PCS. CHIAVI COMBinate IN BUSTA  
 SERIES 12 COMBINATION WRENCHES  
 JEU 12 PIÈCES CLÉS MIXTES EN TROUSSE  
 JUEGO DE 12 PIEZAS SURTIDO DE LLAVES COMBINADAS

12  
 pcs.



445 x 335 mm

COD. **65301001**

€ 20,000

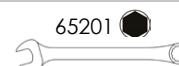

6	7	8	9	10	11	12	13	14	17	19	22
1pc.	1pc.	1pc.	1pc.	1pc.	1pc.	1pc.	1pc.	1pc.	1pc.	1pc.	1pc.

## 65301 SET CHIAVI COMBinate

SERIE 25 PCS. CHIAVI COMBinate IN BUSTA  
 SERIES 25 COMBINATION WRENCHES  
 JEU 25 PIÈCES CLÉS MIXTES EN TROUSSE  
 JUEGO DE 25 PIEZAS SURTIDO DE LLAVES COMBINADAS

25  
 pcs.



695 X 590 mm

COD. **65301002**

€ 78,000

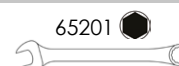

6	7	8	9	10	11	12	13	14
1pc.	1pc.	1pc.	1pc.	1pc.	1pc.	1pc.	1pc.	1pc.

15	16	17	18	19	20	21	22	23
1pc.	1pc.	1pc.	1pc.	1pc.	1pc.	1pc.	1pc.	1pc.

24	25	26	27	28	30	32
1pc.	1pc.	1pc.	1pc.	1pc.	1pc.	1pc.

4



# 4 UTENSILI MANUALI

MANUAL TOOLS  
OUTILS À MAIN  
UTENSILIOS MANUALES

## 65200 CHIAVI A FORCHETTA DOPPIE

CHIAVI A FORCHETTA DOPPIE  
DOUBLE OPEN ENDED WRENCHES  
CLÉS DOUBLES OUVERTES  
LLAVES DOBLE ABIERTAS

EASYPACK | scatola di cartone • cardboard box

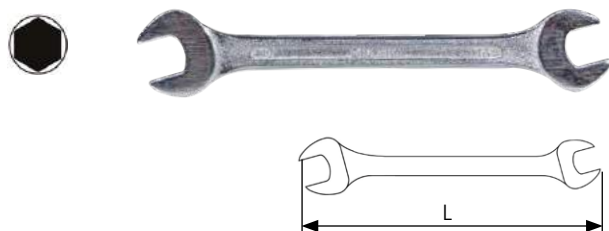

Ø	L mm	PCS.	COD.	€ cad./each
6X7	130	6	65200005	1,240
8X9	140	6	65200010	1,440
10X11	160	6	65200015	1,650
12X13	175	6	65200020	1,880
14X15	185	6	65200025	2,280
16X17	200	6	65200030	2,810
18X19	215	6	65200035	3,510
20X22	235	6	65200040	4,390
21X23	240	6	65200045	5,090
24X27	270	6	65200050	5,960
25X28	280	6	65200055	6,000
30X32	300	6	65200060	8,240

## 65300 SET CHIAVI A FORCHETTA DOPPIE

SERIE 12 PCS. CHIAVI A FORCHETTA DOPPIE  
SERIES 12 DOUBLE OPEN ENDED WRENCHES  
JEU 12 PIÈCES CLÉS DOUBLES OUVERTES  
JUEGO DE 12 PIEZAS DE LLAVES DOBLE ABIERTAS

12  
pcs.

COD. **65300001**  
€ 46,000



445 x 335 mm

65200					
6x7	8x9	10x11	12x13	14x15	16x17
1pc.	1pc.	1pc.	1pc.	1pc.	1pc.
18x19	20x22	21x23	24x27	25x28	30x32
1pc.	1pc.	1pc.	1pc.	1pc.	1pc.

## 65203 CHIAVI POLIGONALI DOPPIA CURVA

CHIAVI POLIGONALI DOPPIA CURVA  
DOUBLE ENDED DEEP OFFSET RING WRENCHES  
CLÉS POLYGONALI CONTRE-COUDÉE  
LLAVES DE ESTRELLA ACODADAS DE DOS BocAS

**EASYPACK** | scatola di cartone • cardboard box

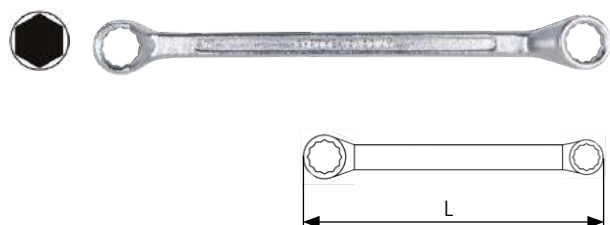

Ø	L mm	PCS.	COD.	€ cad./each
<b>6X7</b>	175	6	65203005	<b>1,950</b>
<b>8X9</b>	190	6	65203010	<b>2,320</b>
<b>10X11</b>	200	6	65203015	<b>2,500</b>
<b>12X13</b>	220	6	65203020	<b>2,830</b>
<b>14X15</b>	240	6	65203025	<b>3,410</b>
<b>16X17</b>	255	6	65203030	<b>4,280</b>
<b>18X19</b>	280	6	65203035	<b>4,980</b>
<b>20X22</b>	300	6	65203040	<b>6,230</b>
<b>21X23</b>	320	6	65203045	<b>7,410</b>
<b>24X27</b>	340	6	65203050	<b>8,800</b>
<b>25X28</b>	340	6	65203055	<b>8,840</b>
<b>30X32</b>	370	6	65203060	<b>11,250</b>



## 65303 SET CHIAVI POLIGONALI DOPPIA CURVA

SERIE 12 PCS. CHIAVI POLIGONALI DOPPIA CURVA  
SERIES 12 DOUBLE ENDED DEEP OFFSET RING WRENCHES  
JEU 12 PIÈCES CLÉS POLYGONALI CONTRE-COUDÉE  
JUEGO DE 12 PIEZAS DE LLAVES DE ESTRELLA ACODADAS DE DOS BocAS

12  
pcs.

COD. **65303001**  
€ 57,000



445 x 335 mm

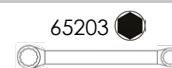

6x7 1pc.	8x9 1pc.	10x11 1pc.	12x13 1pc.	14x15 1pc.	16x17 1pc.
18x19 1pc.	20x22 1pc.	21x23 1pc.	24x27 1pc.	25x28 1pc.	30x32 1pc.

4





# 4 UTENSILI MANUALI

MANUAL TOOLS  
OUTILS À MAIN  
UTENSILIOS MANUALES

**65208**

## CHIAVI A CRICCHETTO

CHIAVI DOPPIE A CRICCHETTO CR-V FINITURA A SPECCHIO  
DOUBLE END RATCHET WRENCHES CR-V MIRROR FINISH  
CLÉS MIXTE À CLIQUET CR-V FINITION MIROIR  
LLAVES COMBINADAS DE CARRACA CR-V ACABADO A ESPEJO

**EASYPACK** | scatola di cartone • cardboard box

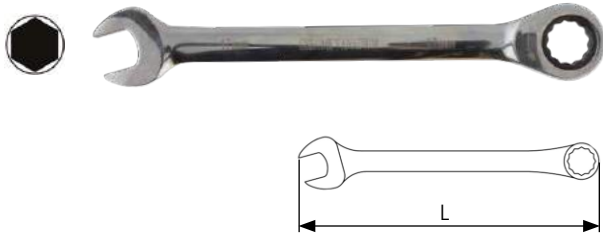

Ø	L mm	PCS.	COD.	€ cad./each
8	140	6	65208015	6,500
9	148	6	65208020	6,670
10	162	6	65208025	7,070
11	166	6	65208030	7,250
12	174	6	65208035	8,080
13	178	6	65208040	8,490
14	192	6	65208045	8,720
15	200	6	65208050	9,130
16	212	6	65208055	9,730
17	225	6	65208060	10,700
18	238	6	65208065	11,200
19	246	6	65208070	11,500

Ø	COD.	€ box
8	65208015001	7,570
9	65208020001	7,740
10	65208025001	8,150
11	65208030001	8,320
12	65208035001	9,150
13	65208040001	9,560
14	65208045001	9,800
15	65208050001	10,200
16	65208055001	10,800
17	65208060001	11,700
18	65208065001	12,300
19	65208070001	12,600



**SELPACK**  
1 pc.





# 65310 SET CHIAVI A CRICCHETTO

SERIE 6 PCS. CHIAVI DOPPIE A CRICCHETTO  
SERIES 6 DOUBLE RATCHET WRENCHES  
JEU 6 PIÈCES CLÉS MIXTE À CLIQUET  
JUEGO DE 6 PIEZAS DE LLAVES COMBINADAS DE CARRACA



6 pcs.

COD. **65310001**

€ 46,000

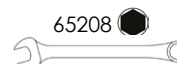

8 1pc.	10 1pc.	12 1pc.	13 1pc.	14 1pc.	17 1pc.
-----------	------------	------------	------------	------------	------------

230 X 110 X 30 mm

# 65310 SET CHIAVI A CRICCHETTO

SERIE 12 PCS. CHIAVI DOPPIE A CRICCHETTO  
SERIES 12 DOUBLE RATCHET WRENCHES  
JEU 12 PIÈCES CLÉS MIXTE À CLIQUET  
JUEGO DE 12 PIEZAS DE LLAVES COMBINADAS DE CARRACA



12 pcs.

COD. **65310002**

€ 97,000



8 1pc.	9 1pc.	10 1pc.	11 1pc.	12 1pc.	13 1pc.
14 1pc.	15 1pc.	16 1pc.	17 1pc.	18 1pc.	19 1pc.

250 X 250 X 30 mm





# 4 UTENSILI MANUALI

MANUAL TOOLS  
OUTILS À MAIN  
UTENSILIOS MANUALES

**65210**

## CHIAVI A CRICCHETTO E SNODO

CHIAVI DOPPIE A CRICCHETTO SNODATE CR-V FINITURA A SPECCHIO  
DOUBLE END FLEXIBLE RATCHET WRENCHES CR-V WITH MIRROR FINISH  
CLÉS MIXTE À CLIQUET ARTICULÉ CR-V FINITION MIROIR  
LLAVES COMBINADAS ARTICULADAS DE CARRACA CR-V ACABADO A ESPEJO

**EASYPACK** | scatola di cartone • cardboard box

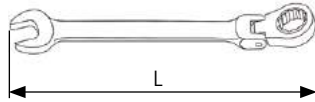

Ø	L mm	PCS.	COD.	€ cad./each
8	140	6	65210015	8,250
9	148	6	65210020	8,900
10	162	6	65210025	9,090
11	166	6	65210030	9,490
12	174	6	65210035	10,500
13	178	6	65210040	10,700
14	192	6	65210045	11,400
15	200	6	65210050	11,800
16	212	6	65210055	12,400
17	225	6	65210060	13,600
18	238	6	65210065	14,400
19	246	6	65210070	14,700

Ø	COD.	€ box
8	65210015001	9,320
9	65210020001	9,970
10	65210025001	10,200
11	65210030001	10,600
12	65210035001	11,600
13	65210040001	11,800
14	65210045001	12,400
15	65210050001	12,800
16	65210055001	13,500
17	65210060001	14,700
18	65210065001	15,400
19	65210070001	15,800



**SELPACK**  
1 pc.



## 65315 SET CHIAVI A CRICCHETTO E SNODO

SERIE 6 PCS. CHIAVI DOPPIE A CRICCHETTO SNODATE  
 SERIES 6 DOUBLE END FLEXIBLE RATCHET WRENCHES  
 'JEU 6 PIÈCES CLÉS MIXTE À CLIQUET ARTICULE'  
 JUEGO DE 6 PIEZAS LLAVES COMBINADAS ARTICULADAS DE CARRACA



6  
pcs.

COD. **65315001**

€ 56,000

65210

8 1pc.	10 1pc.	12 1pc.	13 1pc.	14 1pc.	17 1pc.
-----------	------------	------------	------------	------------	------------

230 X 180 X 30 mm

## 65315 SET CHIAVI A CRICCHETTO E SNODO

SERIE 12 PCS. CHIAVI DOPPIE A CRICCHETTO SNODATE  
 SERIES 12 DOUBLE END FLEXIBLE RATCHET WRENCHES  
 'JEU 12 PIÈCES CLÉS MIXTE À CLIQUET ARTICULE'  
 JUEGO DE 12 PIEZAS LLAVES COMBINADAS ARTICULADAS DE CARRACA



12  
pcs.

COD. **65315002**

€ 118,000

65210

8 1pc.	9 1pc.	10 1pc.	11 1pc.	12 1pc.	13 1pc.
14 1pc.	15 1pc.	16 1pc.	17 1pc.	18 1pc.	19 1pc.

250 X 250 X 30 mm

4





# 4 UTENSILI MANUALI

MANUAL TOOLS  
OUTILS À MAIN  
UTENSILIOS MANUALES

## 65301 SET CHIAVI COMBinate COLORATE

SERIE 6 PCS. CHIAVI COMBinate COLORATE, OGNI MISURA UN COLORE  
SERIES 6 COLOURED COMBINATION WRENCHES, A COLOUR FOR EACH SIZE  
JEU 6 PIÈCES CLÉS MIXTES, COLORÉES, UNE COULEUR PAR DIMENSION  
JUEGO DE 6 PIEZAS SURTIDO DE LLAVES COMBINADAS DE COLORES, CADA MEDIDA UN COLOR



6  
pcs.

220 X 110 X 45 mm

COD. **65301050**

€ 42,000

65201

8	10	12	13	14	17
1pc.	1pc.	1pc.	1pc.	1pc.	1pc.

## 65301 SET CHIAVI COMBinate COLORATE

SERIE 11 PCS. CHIAVI COMBinate COLORATE, OGNI MISURA UN COLORE  
SERIES 11 COLOURED COMBINED WRENCHES, A COLOUR FOR EACH SIZE  
JEU 11 PIÈCES CLÉS MIXTES, COLORÉES, UNE COULEUR PAR DIMENSION  
JUEGO DE 11 PIEZAS SURTIDO DE LLAVES COLOREADAS, CADA MEDIDA UN COLOR



11  
pcs.

250 X 160 X 50 mm

COD. **65301051**

€ 68,000

65201

7	8	9	10	11	12	13	14	15	17	19
1pc.	1pc.	1pc.	1pc.	1pc.	1pc.	1pc.	1pc.	1pc.	1pc.	1pc.



## 65317 SET CHIAVI A CRICCHETTO REVERSIBILE CON "STOP RING"

SERIE 5 PCS. CHIAVI A CRICCHETTO REVERSIBILI CON SISTEMA STOP-RING  
 SERIES 5 REVERSIBLE RATCHET WRENCHES WITH STOP-RING SYSTEM  
 JEU 5 PIÈCES CLÉS À CLIQUET RÉVERSIBLES AVEC SYSTÈME STOP-RING  
 JUEGO DE 5 PIEZAS DE LLAVES CON CARRACA REVERSIBLE CON SISTEMA STOP-RING



5  
pcs.

COD. **65317001**  
€ 130,700





8x10 1pc.	12x13 1pc.	14x15 1pc.	16x18 1pc.	17x19 1pc.
--------------	---------------	---------------	---------------	---------------

130 X 300 X 50 mm

## 65216 CHIAVE PER PONTEGGI

CHIAVE DOPPIA POLIGONALE A CRICCHETTO PER PONTEGGI  
 DOUBLE POLYGONAL RATCHET WRENCH FOR SCAFFOLDING  
 CLÉ DOUBLE POLYGONALE À CLIQUET POUR ÉCHAFAUDAGES  
 LLAVE DOBLE POLIGONAL CON CARRACA PARA ANDAMIOS



L mm			PCS.	COD.	€ cad./each
315	22	21	1	65216025	28,000

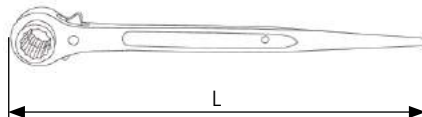

335 X 80 X 60 mm

4





# 4 UTENSILI MANUALI

MANUAL TOOLS  
OUTILS À MAIN  
UTENSILIOS MANUALES

**64230**

ASSORTIMENTI UTENSILI MANUALI

ASSORTIMENTO 29 PCS UTENSILI MANUALI IN ASTUCCIO DI NYLON  
29 PCS HAND TOOLS SET IN NYLON POUCH  
29 PCS JEU DE OUTILS MANUEL AVEC NYLON POCHE  
JUEGO DE 29 PCS HERRAMIENTAS DE MANO EN BOLSA DE NYLON

**NEW!**

29  
pcs.



140 X 40 X 200 mm

COD. **64230500**

€ 19,000

		3			75mm				
		PH0							
		100mm			160mm				
		4,0	6,0	7,0					
		PH1	PH2	PH3					
		TX10	TX15	TX20					
		6	7	8	9	10			
		1,5	2	2,5	3	4	5	5,5	6



**64230**

## ASSORTIMENTI UTENSILI MANUALI

ASSORTIMENTO 30 PCS UTENSILI MANUALI IN ASTUCCIO DI NYLON  
30 PCS HAND TOOLS SET IN NYLON POUCH  
30 PCS JEU DE OUTILS MANUEL AVEC NYLON POCHE  
JUEGO DE 30 PCS HERRAMIENTAS DE MANO EN BOLSA DE NYLON

**NEW!**

30  
pcs.



205 X 60 X 350 mm

COD. **64230510**

€ 71,800

	5	7		3					
	PH1	PH2		PH0					
	6x7	8x9	10x11	12x13	14x15	16x17			
	1,5	2	2,5	3	4	5	6	8	10
	TESTER 250V			160mm					
	250mm			200mm					
	160mm			300gr					
	3m		insulated		160mm				





# 4 UTENSILI MANUALI

MANUAL TOOLS  
OUTILS À MAIN  
UTENSILIOS MANUALES

**64230**

ASSORTIMENTI UTENSILI MANUALI

ASSORTIMENTO 52 PCS UTENSILI MANUALI IN ASTUCCIO DI NYLON  
52 PCS HAND TOOLS SET IN NYLON POUCH  
52 PCS JEU DE OUTILS MANUEL AVEC NYLON POCHE  
JUEGO DE 52 PCS HERRAMIENTAS DE MANO EN BOLSA DE NYLON

**NEW!**

52  
pcs.



140 X 40 X 200 mm

COD. **64230515**

€ 69,000

	PH0	PH1 2pcs.	PH2 2pcs.	PH3						
	PZ0	PZ1 2pcs.	PZ2 2pcs.	PZ3						
	TX10	TX15	TX20	TX25	TX27	TX30				
	2,5	3	4	5	5,5	6				
	3x0,5	4x0,6	5x0,8	5,5x1	6x1,2	7x1,2				
	4	5	6	7	8	9	10	11	12	13
	3x75mm		6x100mm							
	PH1x75mm		PH2x100mm							
	160mm				250mm					
	180mm				TESTER 250V					
	3m				200gr					





# 64230 ASSORTIMENTI UTENSILI MANUALI

ASSORTIMENTO 50 PCS UTENSILI MANUALI VALIGETTA IN TERMOFORMATO  
 50 PCS HAND TOOLS SET IN BLOW MOLD CASE  
 JEU DE 50 PCS OUTILS MANUEL DANS VALISE DE MOULE DE SOUFFLE  
 JUEGO DE 50 PCS HERRAMIENTAS DE MANO EN MALETIN DE MOLDE

**NEW!**

50 pcs.



380 X 80 X 330 mm



COD. **64230400**

€ 72,700

	4,0	5,5	6,5				
	PH1	PH2					
	PZ1	PZ2					
	TX10	TX15	TX20	TX25	TX30		
1/4"x25mm		3	4	5	6		
				1,5	2	2,5	3
				4	5	5,5	6
	6x7	8x9	10x11	12x13	14x15	16x17	
		4					
		PH2					
							1,5
							PH0
	180mm						
							TESTER 250V
	5 pcs.						
							180mm
	250mm						
							160mm
	2 pcs						
							180mm
	3m						
							200gr



## LAMPADE A LED RICARICABILI

Rechargeable LED lamps  
Lampes à LED rechargeables  
Lámparas LED recargables

tested by



**MATLEY**



**SMART  
CLIP**

### LEGENDA



Dimensioni  
Dimensions  
Dimensions  
Dimensiones



Peso  
Weight  
Poids  
Peso



IP



Autonomia  
Autonomy  
Autonomie  
Autonomía



Tipo di LED  
Type of LED  
Type de LED  
Tipo de LED



lumen



Tempo di ricarica  
Charging time  
Temps de charge  
Tiempo de carga



Resistenza ai colpi  
Impact resistance  
Résistance aux chocs  
Resistencia a los golpes



Resistenza alla caduta  
Fall resistance  
Résistance aux chutes  
Resistencia a las caídas



Ogni lampada è certificata e marcata secondo la normativa **CE**

Each lamp is certified and marked according to the regulations **CE**

Chaque lampe est certifiée et marquée conformément à la réglementation **CE**

Cada lámpara está certificada y marcada según la normativa **CE**



Qualità, affidabilità e design curato in ogni minimo dettaglio.

Quality, reliability and design with attention to every detail.

Qualité, fiabilité et design avec une attention portée à chaque détail.

Calidad, fiabilidad y diseño con atención a los detalles más mínimos.



2 anni di garanzia. Ogni lotto di produzione viene accuratamente testato dai tecnici dell'azienda danese.

2 years warranty. Each production lot is thoroughly tested by Danish company technicians.

2 ans de garantie. Chaque lot de production est minutieusement testé par les techniciens de la société danoise.

2 años de garantía. Cada lote de producción es probado exhaustivamente por técnicos de la empresa danesa.

**65981**

## LAMPADA RICARICABILE PORTATILE MINI

LAMPADA RICARICABILE 60/120 LUMEN - IP20  
 RECHARGEABLE LAMP 60/120 LUMEN - IP20  
 LÁMPARA RECARGABLE 60/120 LUMEN - IP20  
 LAMPE RECHARGEABLE 60/120 LUMEN - IP20



120x54x24mm



77g

**NEW!**

IP20

4h/2h  
(step 1/2)

4xSMD LED

60/120 lumen  
(step 1/2)

2.5h



COD.  
65981001

€  
cad./each  
61,200



- Compatta con 4 SMD LED, ad alta luminosità
- Caricatore e cavo USB in dotazione
- 2 livelli di luminosità
- Corpo ergonomico in materiale antiscivolo
- Autonomia fino a 4 ore
- Sistema *smart clip* 4 in 1 appendibile

INCLUSO / INCLUDED  
 INCLUDE / INCLUIDO



- Compact with 4 high-brightness SMD LEDs
- Charger and USB cable supplied
- 2 brightness levels
- Ergonomic body in non-slip material
- Battery life up to 4 hours
- Hanging smart clip 4 in 1 system

- Compacte avec 4 LED SMD haute luminosité
- Chargeur et câble USB fournis
- 2 niveaux de luminosité
- Corps ergonomique en matériau antidérapant
- Autonomie jusqu'à 4 heures
- Système smart clip 4 in 1 permettant de l'accrocher

- Compacta con 4 LED SMD de alta luminosidad
- Cargador y cable USB suministrados
- 2 niveles de luminosidad
- Cuerpo ergonómico de material antideslizante
- Autonomía de hasta 4 horas
- Sistema smart clip para colgar 4 en 1

**65981**

## DISPLAY PER LAMPADE

65981001

ESPOSITORE DA BANCO IN PLEXIGLASS PER 12 LAMPADE  
 12 PCS. LAMPS PLEXIGLASS COUNTER DISPLAY  
 PRÉSENTOIR EN PLEXIGLAS POUR 12 LAMPES  
 MOSTRADOR DE EXPOSICIÓN IN PLEXIGLASS PARA 12 LÁMPARA

**NEW!**

12 pcs.



COD. **65981002**  
 € 734,400



12 pcs.  
 COD. 65981001

230 X 200 X 130 mm





# 4 UTENSILI MANUALI

MANUAL TOOLS  
OUTILS À MAIN  
UTENSILIOS MANUALES

**65981**

## LAMPADA RICARICABILE PORTATILE MEDIA

LAMPADA RICARICABILE 110/220 LUMEN - IP20  
RECHARGEABLE LAMP 110/220 LUMEN - IP20  
LÁMPARA RECARGABLE 110/220 LUMEN - IP20  
LAMPE RECHARGEABLE 110/220 LUMEN - IP20



180x54x27mm



131g

**NEW!**



IP20



4h/2h  
(step 1/2)



8xSMD LED/  
Spot: High  
power LED



110/220 lumen  
(step 1/2)  
Spot: 75 lumen



2.5h



COD. €  
65981005 cad./each  
80,900



- Compatta con 8 SMD LED, ad alta luminosità
- Caricatore e cavo USB in dotazione
- 2 livelli di luminosità
- Corpo ergonomico in materiale antiscivolo
- Autonomia fino a 4 ore
- Sistema *smart clip 4 in 1* appendibile

INCLUSO / INCLUDED  
INCLUDE / INCLUIDO



- Compact with 8 high-brightness SMD LEDs and USB cable supplied
- 2 brightness levels
- Ergonomic body in non-slip material
- Battery life up to 4 hours
- Hanging smart clip 4 in 1 system

- Compacte avec 8 LED SMD haute luminosité
- Chargeur et câble USB fournis
- 2 niveaux de luminosité
- Corps ergonomique en matériau antidérapant
- Autonomie jusqu'à 4 heures
- Système smart clip 4 in 1 permettant de l'accrocher

- Compacta con 8 LED SMD de alta luminosidad
- Cargador y cable USB suministrados
- 2 niveles de luminosidad
- Cuerpo ergonómico de material antideslizante
- Autonomía de hasta 4 horas
- Sistema smart clip para colgar 4 en 1

**65981**

## DISPLAY PER LAMPADE 65981005

ESPOSITORE DA BANCO IN PLEXIGLASS PER 12 LAMPADE  
12 PCS. LAMPS PLEXIGLASS COUNTER DISPLAY  
PRÉSENTOIR EN PLEXIGLASS POUR 12 LAMPES  
MOSTRADOR DE EXPOSICIÓN IN PLEXIGLASS PARA 12 LÁMPARA

**NEW!**

12  
pcs.

COD. **65981006**  
€ 970,400



12 pcs.  
COD. 65981005

190 X 190 X 190 mm

**65981**

## LAMPADA RICARICABILE PORTATILE A PENNA

LAMPADA RICARICABILE 110/220 LUMEN - IP20  
 RECHARGEABLE LAMP 110/220 LUMEN - IP20  
 LÁMPARA RECARGABLE 110/220 LUMEN - IP20  
 LAMPE RECHARGEABLE 110/220 LUMEN - IP20



150x34x13mm



52g

**NEW!**

IP20

4h/2h  
(step 1/2)  
Spot: 2.5h4xSMD LED/  
Spot: High  
power LED50/100 lumen  
(step 1/2)  
Spot: 50 lumen

2.5h



COD. €  
 65981010 cad./each  
 39,800



- Corpo ultra-sottile con 4 SMD LED, ad alta luminosità
- Cavo USB in dotazione
- 2 livelli di luminosità + SPOT LIGHT
- Corpo ergonomico in materiale antiscivolo
- Autonomia fino a 4 ore

INCLUSO / INCLUDED  
 INCLUDE / INCLUIDO



- Ultra-thin body with 4 SMD LEDs, high brightness
- USB cable supplied
- 2 brightness levels + SPOT LIGHT
- Ergonomic body in non-slip material
- Battery life up to 4 hours

- Corps ultra-mince avec 4 LED SMD, haute luminosité
- Câble USB fourni
- 2 niveaux de luminosité + SPOT LIGHT
- Corps ergonomique en matériau antidérapant
- Autonomie jusqu'à 4 heures

- Cuerpo ultrafino con 4 LED SMD de alta luminosidad
- Cable USB suministrado
- 2 niveles de luminosidad + SPOT LIGHT
- Cuerpo ergonómico de material antideslizante
- Autonomía de hasta 4 horas

**65981**

## DISPLAY PER LAMPADE

65981010

ESPOSITORE DA BANCO IN PLEXIGLASS PER 12 LAMPADE  
 12 PCS. LAMPS PLEXIGLASS COUNTER DISPLAY  
 PRÉSENTOIR EN PLEXIGLAS POUR 12 LAMPES  
 MOSTRADOR DE EXPOSICIÓN IN PLEXIGLASS PARA 12 LÁMPARA

**NEW!**12  
pcs.

COD. **65981011**  
 € 477,00



12 pcs.  
 COD. 65981010

140 X 160 X 160 mm





# 4 UTENSILI MANUALI

MANUAL TOOLS  
OUTILS À MAIN  
UTENSILIOS MANUALES

**65981**

## LAMPADA RICARICABILE PIEGHEVOLE

LAMPADA RICARICABILE PIEGHEVOLE 125/250 LUMEN - IP20  
FOLDABLE RECHARGEABLE LAMP 125/250 LUMEN - IP20  
LAMPE RECHARGEABLE PLIABLE 125/250 LUMEN - IP20  
LÁMPARA RECARGABLE PLEGABLE 125/250 LUMEN - IP20



248x40x32mm



136 g

**NEW!**



IP20



4h/2h  
(step 1/2)  
Spot: 5h



8xSMD LED/  
Spot: High  
power LED



125/250 lumen  
(step 1/2)  
Spot: 50 lumen



3 h



COD. €  
65981015 cad./each  
86,900



- Testa pieghevole a 270°, ultra-sottile con 8 SMD LED
- Caricatore e cavo USB in dotazione
- 2 livelli di luminosità
- Corpo ergonomico in materiale antiscivolo
- Autonomia fino a 4 ore

INCLUSO / INCLUDED  
INCLUDE / INCLUIDO



- Ultra-thin 270° folding head with 8 SMD LEDs
- Charger and USB cable supplied
- 2 brightness levels
- Ergonomic body in non-slip material
- Battery life up to 4 hours

- Tête repliable à 270° ultra-fine avec 8 LED SMD
- Chargeur et câble USB fournis
- 2 niveaux de luminosité
- Corps ergonomique en matériau antidérapant
- Autonomie jusqu'à 4 heures

- Cabeza plegable a 270° ultrafina con 8 LED SMD
- Cargador y cable USB suministrados
- 2 niveles de luminosidad
- Cuerpo ergonómico de material antideslizante
- Autonomía de hasta 4 horas

**65981**

## DISPLAY PER LAMPADE 65981015

ESPOSITORE DA BANCO IN PLEXIGLASS PER 12 BIT-SETS  
12 PCS. BIT-SETS PLEXIGLASS COUNTER DISPLAY  
PRÉSENTOIR EN PLEXIGLASS POUR 12 JEUX D'EMBOUS  
MOSTRADOR DE EXPOSICIÓN IN PLEXIGLASS PARA 12 BIT-SET

**NEW!**



12  
pcs.

COD. **65981016**  
€ 1'042,700



12 pcs.  
COD. 65981015

170 X 140 X 220 mm



## 65981 LAMPADA DA TESTA A BATTERIA

LAMPADA DA TESTA A BATTERIA 75/150 LUMEN - IP54  
BATTERY POWERED HEAD LAMP 75/150 LUMEN - IP54  
LAMPE FRONTALE A BATTERIE 75/150 LUMEN - IP54  
LÁMPARA FRONTAL DE BATERÍA 75/150 LUMEN - IP54



70x35x40mm



100g

**NEW!**



IP54



14h/7h  
(step 1/2)



5xSMD LED



75/150 lumen  
(step 1/2)



COD. 65981020  
€ cad./each 51,200



- Lampada da testa con 5 SMD LED, ad alta luminosità
- 2 livelli di luminosità
- Autonomia fino a 14 ore
- Sensore acceso / spento senza contatto "mani libere"
- Consente di lavorare a mani libere
- Nr. 3 batterie AAA 1,5V incluse



2.5h

INCLUSO / INCLUDED  
INCLUDE / INCLUIDO

**3x**



- Head lamp with 5 SMD LEDs, high brightness
- 2 brightness levels
- Battery life up to 14 hours
- Hands-free on/off sensor operation
- It allows you to work hands-free
- No. 3 AAA 1.5 V batteries included

- Lampe frontale avec 5 LED SMD, haute luminosité
- 2 niveaux de luminosité
- Autonomie jusqu'à 14 heures
- Capteur marche / arrêt sans contact "mains libres"
- Elle vous permet de travailler les mains libres
- N° 3 piles AAA 1.5V incluses

- Lámpara frontal con 5 LED SMD de alta luminosidad
- 2 niveles de luminosidad
- Autonomía de hasta 14 horas
- Sensor de encendido/apagado sin contacto «manos libres»
- Permite trabajar con las manos libres
- 3 pilas AAA 1,5 V incluidas

## 65981 DISPLAY PER LAMPADE 65981020

ESPOSITORE DA BANCO IN PLEXIGLASS PER 6 BIT-SETS  
6 PCS. BIT-SETS PLEXIGLASS COUNTER DISPLAY  
PRÉSENTOIR EN PLEXIGLAS POUR 6 JEUX D'EMBOUS  
MOSTRADOR DE EXPOSICIÓN IN PLEXIGLASS PARA 6 BIT-SET

**NEW!**

6 pcs.



230 X 200 X 130 mm

COD. **65981021**  
€ 306,900



12 pcs.  
COD. 65981020

4





# 4 UTENSILI MANUALI

MANUAL TOOLS  
OUTILS À MAIN  
UTENSILIOS MANUALES

**65981**

## LAMPADA COB LED CON BASE DI RICARICA

LAMPADA RICARICABILE CON BASE 250/500 LUMEN - IP65  
RECHARGEABLE LAMP WITH BASE 250/500 LUMEN - IP65  
LAMPE RECHARGEABLE AVEC BASE 250/500 LUMEN - IP65  
LÁMPARA RECARGABLE CON BASE 250/500 LUMEN - IP65



190x60x32mm



263 g

**NEW!**



IP65



4.5h/2h  
(step 1/2)  
Spot: 3h



COB LED  
Spot: High  
power LED



250/500 lumen  
(step 1/2)  
Spot: 175 lumen



5 h



COD.

65981025

€  
cad./each  
**135,400**



- Compatta, COB LED ad alta luminosità
- Caricatore in dotazione e cavo USB
- 2 livelli di luminosità + SPOT LIGHT
- Corpo ergonomico in materiale antiscivolo
- Autonomia fino a 4,5 ore
- Base magnetica orientabile a 180°

INCLUSO / INCLUDED  
INCLUDE / INCLUIDO



- Compact, high brightness COB LED
- Charger and USB cable supplied
- 2 brightness levels + SPOT LIGHT
- Ergonomic body in non-slip material
- Battery life up to 4.5 hours
- 180° adjustable magnetic base

- LED COB compacte et haute luminosité
- Chargeur fourni et câble USB
- 2 niveaux de luminosité + SPOT LIGHT
- Corps ergonomique en matériau antidérapant
- Autonomie jusqu'à 4,5 heures
- Base magnétique réglable à 180 °

- Compacta, LED COB de alta luminosidad
- Cargador suministrado y cable USB
- 2 niveles de luminosidad + SPOT LIGHT
- Cuerpo ergonómico de material antideslizante
- Autonomía de hasta 4,5 horas
- Base magnética orientable de 180°



### FOCUS ON



Modello prodotto in Danimarca con elevata impermeabilità all'acqua e alle polveri.

Model produced in Denmark with high impermeability to water and dust.

Modèle fabriqué au Danemark avec une étanchéité élevée à l'eau et à la poussière.

Modelo fabricado en Dinamarca con alta impermeabilidad al agua y al polvo.





**65981**

## PROIETTORE RICARICABILE CON POWER BANK

PROIETTORE RICARICABILE CON POWER BANK 500/1000 LUMEN - IP54  
 PROJECTEUR RECHARGEABLE AVEC POWER BANK 500/1000 LUMEN - IP54  
 RECHARGEABLE PROJECTOR WITH POWER BANK 500/1000 LUMEN - IP54  
 PROJECTEUR RECHARGEABLE AVEC POWER BANK 500/1000 LUMEN - IP54

**NEW!**

230x13x43mm



885 g



40xSMD LEDs

500/1000 lumen  
(step 1/2)

IP54

4h/2h  
(step 1/2)

3.5h



IK07



1m

COD.

65981030

€  
cad./each

140,300



- Proiettore ricaricabile, scocca in metallo
- Caricatore e cavo USB in dotazione
- Per utilizzo nei cantieri edili
- Dotato di supporto orientabile a 180°
- Fornisce una luminosità fino a 1.000 lumen
- Diffusore posteriore in metallo antisurriscaldamento
- Funziona da power-bank con attacco USB
- Autonomia fino a 4 ore

INCLUSO / INCLUDED  
 INCLUDE / INCLUIDO



- Rechargeable projector, metal body
- Charger and USB cable supplied
- For use on construction sites
- Equipped with 180° adjustable support
- Provides brightness up to 1,000 lumens
- Rear diffuser in anti-overheating metal
- It works as a power-bank with a USB connection
- Battery life up to 4 hours

- Projecteur rechargeable, coque en métal
- Chargeur et câble USB fournis
- Pour une utilisation sur les chantiers de construction
- Équipée d'un support réglable à 180 °
- Fournit une luminosité allant jusqu'à 1 000 lumens
- Diffuseur arrière en métal anti-surchauffe
- Fonctionne comme une power bank avec une connexion USB
- Autonomie jusqu'à 4 heures

- Projecteur rechargeable, coque en métal
- Chargeur et câble USB fournis
- Pour une utilisation sur les chantiers de construction
- Équipée d'un support réglable à 180 °
- Fournit une luminosité allant jusqu'à 1 000 lumens
- Diffuseur arrière en métal anti-surchauffe
- Fonctionne comme une power bank avec une connexion USB
- Autonomie jusqu'à 4 heures

**FOCUS ON**

L'elevato flusso luminoso (lumen) di questo proiettore abbinato alla sua alta capacità di illuminamento (1200 lux), lo rende molto indicato per illuminare ampie superfici. The high luminous flux (lumens) of this projector combined with its high illumination capacity (1200 lux), makes it very suitable for illuminating large areas.

Le flux lumineux élevé (lumens) de ce projecteur, associé à sa grande capacité d'éclairage (1200 lux), le rend très approprié pour éclairer de grandes surfaces.

El alto flujo luminoso (lúmenes) de este proyector, combinado con su alta capacidad de iluminación (1200 lux), lo hace muy adecuado para iluminar grandes superficies.



# PORTA-UTENSILI

## BORSE E CONTENITORI PORTA-UTENSILI

*Tool bags and containers*

*Sacs et conteneurs porte-ustensiles*

*Bolsas y contenedores portautensilios*

tested by



**MATLEY**



Realizzate in poliestere 600d, doppie cuciture nei punti più delicati, fibbie e moschettoni in metallo.

*Made of 600d polyester, double stitching at the most delicate points, metal buckles and snap hooks.*

*Fabriqués en polyester 600d, double couture dans les points les plus délicats, boucles et mousquetons en métal.*

*Confeccionada en poliéster 600d, doble costura en los puntos más delicados, hebillas y mosquetones de metal.*



Maniglie rinforzate e rivestite in morbida gomma antiscivolo, spallacci imbottiti.

*Reinforced handles covered in soft non-slip rubber, padded shoulder straps.*

*Poignées renforcées recouvertes de caoutchouc souple antidérapant, bretelles matelassées.*

*Asas reforzadas y recubiertas de suave goma antideslizante, hombreras acolchadas.*



Piedini e fondi rivestiti in gomma impermeabile.

*Feet and bottoms covered with waterproof rubber.*

*Les pieds et les fonds sont recouverts de caoutchouc imperméable.*

*Patas y parte inferior recubiertas de goma impermeable.*



## 65991 FODERO PORTA TRAPANO

FODERO PORTA TRAPANO 7 TASCHE  
DRILL HOLDER 7 POCKETS  
PORTE PERCEUSE 7 POCHES  
FUNDA PORTATALADRO CON 7 BOLSILLOS

**NEW!**



17x30 cm

COD.	€ cad./each
65991001	12,700



- Poliestere 600 denari, ad altissima resistenza
- Passante posteriore per cintura
- Tasca porta trapano con fibbia di chiusura
- Sette tasche aggiuntive

- 600 denier polyester, very high resistance
- Rear belt loop
- Drill pocket with locking buckle
- Seven additional pockets

- Polyester 600 d, très haute résistance
- Boucle arrière pour ceinture
- Poche pour perceuse avec boucle de verrouillage
- Sept poches supplémentaires

- Poliéster de 600 denieres, de muy alta resistencia.
- Trabilla posterior para el cinturón
- Bolsillo parataladro con hebilla de cierre
- Siete bolsillos adicionales

## 65991 FODERO PORTAUTENSILI CON CINTURA

FODERO PORTAUTENSILI CON CINTURA 8 TASCHE  
TOOL HOLDER COVER WITH BELT 8 POCKETS  
PORTE-OUTIL AVEC CEINTURE DE 8 POCHES  
FUNDA PORTAUTENSILIOS CON CINTURÓN PARA 8 BOLSILLOS

**NEW!**



28x19,5 cm

COD.	€ cad./each
65991003	13,500



- Poliestere 600 denari, ad altissima resistenza
- Cintura regolabile inclusa
- Otto robuste tasche imbottite
- Due ganci metallici per flessometro e chiave combinata
- Cordino con moschettone, due passanti in tessuto

- 600 denier polyester, very high resistance
- Adjustable belt included
- Eight sturdy padded pockets
- Two metal hooks for tape measure and combination wrench
- Lanyard with carabiner, two fabric loops

- Polyester 600 d, très haute résistance
- Ceinture ajustable incluse
- Huit poches matelassées robustes
- Deux crochets métalliques pour mètre ruban et clé mixte
- Cordon avec mousqueton, deux passants en tissu

- Poliéster de 600 denieres, de muy alta resistencia.
- Cinturón ajustable incluido
- Ocho resistentes bolsillos acolchados
- Dos ganchos metálicos para flexómetro y llave combinada
- Cordón con mosquetón, dos trabillas de tela





# 4 UTENSILI MANUALI

MANUAL TOOLS  
OUTILS À MAIN  
UTENSILIOS MANUALES

**65991**

## BORSA PER UTENSILI CON CINTURA

BORSA PER UTENSILI CON CINTURA 8 TASCHE  
BAG FOR TOOLS WITH BELT 8 POCKETS  
SAC POUR OUTILS AVEC CEINTURE DE 8 POCHES  
BOLSA PARA UTENSILIOS CON CINTURÓN DE 8 BOLSILLOS

**NEW!**



23,5x23,5x15 cm

COD. €  
65991005 cad./each  
**19,600**

- Poliestere 600 denari, ad altissima resistenza
- Cintura regolabile inclusa
- Otto tasche di cui una a marsupio
- Gancio metallico per flessometro



- 600 denier polyester, very high resistance
- Adjustable belt included
- Eight pockets, one of which is a pouch
- Metal measuring tape hook

- Polyester 600 d, très haute résistance
- Ceinture ajustable incluse
- Huit poches, dont une poche-marsupial
- Crochet métallique pour mètre-ruban

- Poliéster de 600 denieres, de muy alta resistencia
- Cinturón ajustable incluido
- Ocho bolsillos, uno de los cuales tipo riñonera
- Gancho metálico para flexómetro

**65991**

## CESTELLO APPENDIBILE

CESTELLO APPENDIBILE 22 TASCHE  
HANGING BASKET 22 POCKETS  
PANIER À SUSPENDRE 22 POCHES  
CESTO COLGANTE CON 22 BOLSILLOS

**NEW!**



22x35x22 cm

COD. €  
65991020 cad./each  
**35,500**

- Poliestere 600 denari, ad altissima resistenza
- Manico sganciabile
- Piedini in gomma, cordino con moschettone
- Ventidue tasche esterne
- 3 separatori interni



- 600 denier polyester, very high resistance
- Detachable handle
- Rubber feet, lanyard with snap hook
- Twenty-two external pockets
- 3 internal separators

- Polyester 600 d, très haute résistance
- Poignée détachable
- Pieds en caoutchouc, lanière avec mousqueton
- Vingt-deux poches extérieures
- 3 séparateurs internes

- Poliéster de 600 denieres, de muy alta resistencia.
- Asa desmontable
- Patas de goma, cordón con mosquetón
- Veintidós bolsillos externos
- 3 separadores internos



## 65991 CESTELLO RIPIEGABILE CON TRACOLLA

CESTELLO RIPIEGABILE CON TRACOLLA 19 TASCHE  
FOLDABLE BASKET WITH SHOULDER STRAP 19 POCKETS  
PANIER Pliable AVEC SAC D'ÉPAULE DE 19 POCHES  
CESTA PLEGABLE CON BANDOLERA CON 19 BOLSILLOS

**NEW!**

19

15kg

10L



40x20x30 cm

COD. €  
65991021 cad./each  
31,300



- Poliestere 600 denari ad altissima resistenza
- Struttura ripiegabile
- Manico tubolare in metallo, pieghevole
- Impugnatura in morbida gomma
- Tracolla sganciabile
- 19 tasche e passanti porta-utensili

- 600 denier polyester, very high resistance
- Foldable structure
- Folding tubular metal handle
- Soft rubber handle
- Detachable shoulder strap
- 19 pockets and tool loops

- Polyester 600 d, très haute résistance
- Structure pliable
- Poignée métallique tubulaire pliante
- Poignée en caoutchouc souple
- Bandoulière détachable
- 19 poches et passants porte-outils

- Poliéster de 600 denieres, de muy alta resistencia
- Estructura plegable
- Asa tubular de metal, plegable
- Empuñadura suave de goma
- Bandolera desmontable
- 19 bolsillos y trabillas portautensilios

## 65991 CESTELLO RICHIUDIBILE CON TRACOLLA

CESTELLO RICHIUDIBILE CON TRACOLLA 24 TASCHE  
REFILLABLE BASKET WITH SHOULDER STRAP 24 POCKETS  
PANIER REFERMABLE AVEC SANGLE D'ÉPAULE À 24 POCHES  
CESTA CON CIERRE CON BANDOLERA DE 24 BOLSILLOS

**NEW!**

24

20kg

25L



44x25x34 cm

COD. €  
65991025 cad./each  
57,500



- Poliestere 600 denari ad altissima resistenza
- Struttura rigida
- Manico tubolare in metallo
- Impugnatura in morbida gomma
- Tracolla sganciabile e copertura rimovibile
- 24 tasche e passanti porta-utensili
- Fondo in gomma anti-urto

- 600 denier polyester, very high resistance
- Rigid structure
- Tubular metal handle
- Soft rubber handle
- Detachable shoulder strap and removable cover
- 24 pockets and tool loops
- Anti-shock rubber base

- Polyester 600 d, très haute résistance
- Structure rigide
- Poignée métallique tubulaire
- Poignée en caoutchouc souple
- Bandoulière amovible et housse amovible
- 24 poches et passants porte-outils
- Fond en caoutchouc anti-cho

- Poliéster de 600 denieres, de muy alta resistencia
- Estructura rígida
- Asa tubular de metal
- Empuñadura suave de goma
- Bandolera desmontable y funda extraíble
- 24 bolsillos y trabillas portautensilios
- Fondo de goma antiimpactos





# 4 UTENSILI MANUALI

MANUAL TOOLS  
OUTILS À MAIN  
UTENSILIOS MANUALES

**65991**

## BORSA FONDO RIGIDO CON TRACOLLA

BORSA FONDO RIGIDO CON TRACOLLA 52 TASCHE  
RIGID BASE BAG WITH SHOULDER STRAP 52 POCKETS  
SAC À FONDS RIGIDE AVEC SANGLE À L'ÉPAULE 52 POCHES  
BOLSA CON PARTE INFERIOR RÍGIDA Y BANDOLERA DE 52 BOLSILLOS

**NEW!**



43x38x30 cm

COD.	€
65991030	cad./each <b>46,800</b>



- Poliestere 600 denari ad altissima resistenza
- Fondo in gomma anti-urto
- Fornita con tracolla
- 52 tasche e passanti porta-utensili

- 600 denier polyester, very high resistance
- Anti-shock rubber base
- Supplied with shoulder strap
- 52 pockets and tool loops

- Polyester 600 d, très haute résistance
- Fond en caoutchouc anti-choc
- Fourni avec une bandoulière
- 52 poches et passants porte-outils

- Poliéster de 600 denieres, de muy alta resistencia
- Fondo de goma antiimpactos
- Bandolera incluida
- 52 bolsillos y trabillas portautensilios

**65991**

## GILET TECNICO

GILET TECNICO DA LAVORO MULTITASCHE  
MULTIPOCKET TECHNICAL WORK VEST  
GILET DE TRAVAIL MULTITÂCHE TECHNIQUE  
CHALECO TÉCNICO DE TRABAJO MULTIBOLSILLO

**NEW!**



65x50 cm

COD.	€
65991040	cad./each <b>47,600</b>



- Poliestere 600 denari ad altissima resistenza
- Realizzato in tessuto a rete ad alta traspirazione
- Taglia unica con fibbie laterali per la regolazione
- Spalline apribili con chiusura a strappo
- Bande catarifrangenti

- 600 denier polyester, very high resistance
- Made of highly breathable mesh fabric
- One size with side buckles for adjustment
- Shoulder straps that can be opened with Velcro closure
- Reflective bands

- Polyester 600 d, très haute résistance
- Fabriqué en tissu hautement respirant
- Taille unique avec boucles latérales pour le réglage
- Bretelles pouvant être ouvertes avec une fermeture velcro
- Bandes réfléchissantes

- Poliéster de 600 denieres, de muy alta resistencia
- Confeccionado en tejido de malla de elevada transpiración
- Talla única con hebillas laterales de ajuste
- Hombreras con apertura y cierre de velcro
- Bandas reflectantes



## 65991 ZAINO CON ORGANIZER

ZAINO CON ORGANIZER 57 TASCHE  
BACKPACK WITH ORGANISER 57 POCKETS  
SAC À DOS AVEC ORGANISATEUR 57 POCHEs  
MOCHILA CON ORGANIZADOR DE 57 BOLSILLOS

**NEW!**



38x23x49 cm

COD.	€
65991010	cad./each <b>80,800</b>



- Poliestere 600 denari, ad altissima resistenza
- Fornito con paniere interno porta-utensili removibile
- Scomparti interni porta-PC o Tablet
- Spallacci imbottiti con moschettoni metallici
- Manico rinforzato e rivestito in gomma
- Fondo rinforzato in materiale plastico resistente all'acqua
- Schienale ergonomico imbottito
- 57 tasche e passanti porta-utensili

- 600 denier polyester, very high resistance
- Supplied with removable internal tool holder basket
- Internal compartments for a laptop or tablet
- Padded shoulder straps with metal snap hooks
- Reinforced rubber-coated handle
- Reinforced base in water-resistant plastic
- Ergonomic padded backrest
- 57 pockets and tool loops

- Polyester 600 d, très haute résistance
- Livré avec un panier porte-outils interne amovible
- Compartiments internes pour PC ou tablette
- Bretelles rembourrées avec mousquetons métalliques
- Manche caoutchouté renforcé
- Fond renforcé en plastique résistant à l'eau
- Dossier rembourré ergonomique
- 57 poches et passants porte-outils

- Poliéster de 600 denieres, de muy alta resistencia.
- Se suministra con cesta interna portautensilios extraíble
- Compartimentos internos para PC o tablet
- Hombros acolchadas con mosquetones metálicos
- Asa reforzada y recubierta de goma
- Parte inferior reforzada de material plástico resistente al agua
- Respaldo ergonómico acolchado
- 57 bolsillos y trabillas portautensilios

## 65991 TROLLEY CON ORGANIZER

TROLLEY CON ORGANIZER 57 TASCHE  
TROLLEY WITH ORGANISER  
CHARIOT AVEC ORGANISATEUR  
TROLLEY CON ORGANIZADOR

**NEW!**



37x22x54 cm

COD.	€
65991015	cad./each <b>98,800</b>



- Poliestere 600 denari, ad altissima resistenza
- Manico telescopico di trasporto
- Ruote integrate nella struttura
- Fornito con paniere interno porta-utensili removibile
- Scomparti interni porta-PC o Tablet
- Spallacci imbottiti con moschettoni metallici
- Manico rinforzato e rivestito in gomma
- Fondo con piedini

- 600 denier polyester, very high resistance
- Telescopic transport handle
- Wheels integrated into the structure
- Supplied with removable internal tool holder basket
- Internal compartments for a laptop or tablet
- shoulder straps with metal snap hooks
- Reinforced rubber-coated handle
- Base with feet

- Polyester 600 d, très haute résistance
- Poignée de transport télescopique
- Roues intégrées à la structure
- Livré avec un panier porte-outils interne amovible
- Compartiments internes pour PC ou tablette
- Bretelles rembourrées avec mousquetons métalliques
- Manche caoutchouté renforcé
- Bas avec des pieds

- Poliéster de 600 denieres, de muy alta resistencia
- Asa telescópica de transporte
- Ruedas integradas en la estructura
- Se suministra con cesta interna portautensilios extraíble
- Compartimentos internos para PC o tablet
- Hombros acolchadas con mosquetones metálicos
- Asa reforzada y recubierta de goma
- Parte inferior con patas





# 4 UTENSILI MANUALI

MANUAL TOOLS  
OUTILS À MAIN  
UTENSILIOS MANUALES

**65991**

SET CASSETTE PORTAUTENSILI

SET 3 PCS CASSETTE PORTAUTENSILI CON VASSOI INTERNI  
SET 3 PCS TOOL BOXES WITH INTERNAL TRAYS  
SET 3 BOITES A OUTILS AVEC PLATEAUX INTERNES  
SET DE 3 CAJAS DE HERRAMIENTAS CON BANDEJAS INTERNAS

**NEW!**

COD.	€ cad./each
65991100	127,600



FOCUS ON



390 X 180 X 170 mm



470 X 240 X 210 mm



580 X 270 X 260 mm







# 65991 CARRELLO SCOMPONIBILE

CARRELLO SCOMPONIBILE IN TRE PARTI, CON SEPARATORI INTERNI  
 TROLLEY CAN BE SPLIT INTO THREE PARTS, WITH INTERNAL SEPARATORS  
 CHARIOT DÉCOMPOSABLE EN TROIS PARTIES, AVEC SÉPARATEURS INTERNES  
 CARRITO DESMONTABLE EN TRES PARTES, CON SEPARADORES INTERNOS

**NEW!**

COD.	€
65991110	cad./each <b>156,200</b>



820 X 310 X 450 mm

**!** FOCUS ON



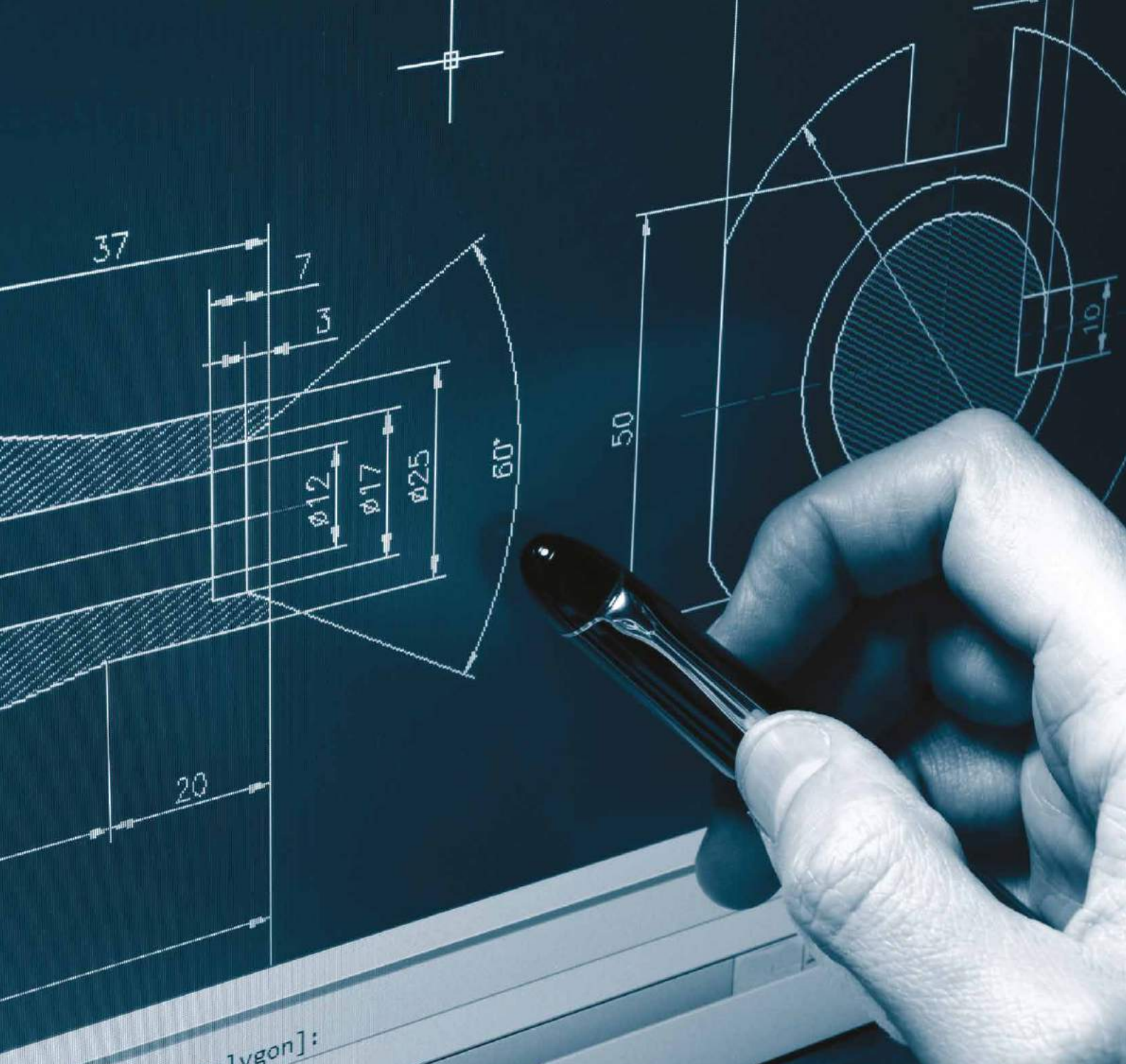

L'attenzione ai dettagli che da sempre contraddistingue il marchio LTI si riflette anche nel supporto alla clientela: nelle seguenti pagine vogliamo guidarvi nell'utilizzo dei nostri prodotti in maniera semplice ma allo stesso tempo fornendovi una panoramica precisa e dettagliata.

Le nostre schede tecniche sono lo strumento perfetto per avvicinarsi a qualsiasi tipo di operazione in sicurezza e con la tranquillità di aver scelto lo strumento più adatto per il conseguimento del risultato ottimale.

The attention to detail that has always distinguished the LTI brand is also reflected in the customer support. The following pages will guide you on how to use our products in a simple way and also provide you with accurate and detailed information.

Our technical datasheets are the perfect tool to help you carry out any type of operation safely and with the certainty of having chosen the right tool for the best results.

L'attention apportée au détail qui distingue depuis toujours la marque LTI se reflète également dans le support à la clientèle. Dans les pages suivantes, nous voulons vous guider dans l'utilisation de nos produits de façon simple mais en fournissant aussi un aperçu précis et détaillé. Nos fiches techniques sont l'outil idéal pour approcher tout type d'opération en toute sécurité et en étant certain de choisir le bon outil pour l'obtention de résultats optimaux.

La atención a los detalles que desde siempre distingue a la marca LTI también se refleja en la asistencia a la clientela: en las siguientes páginas encontrarán una guía sobre como usar nuestros productos de manera sencilla, pero al mismo tiempo les ofreceremos una visión completa precisa y detallada.

Nuestras fichas técnicas son el instrumento perfecto para acercarse a cualquier tipo de operación con completa seguridad y con la tranquilidad de haber elegido el instrumento más adecuado para conseguir un resultado óptimo.

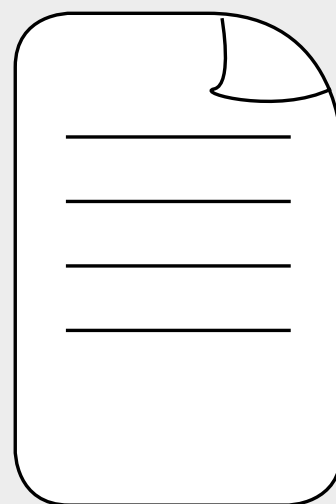



**SCHEDE TECNICHE  
TECHNICAL DATASHEETS  
FICHES TECHNIQUES  
FICHAS TÉCNICAS**

**INSERTI - BITS - EMBOUTS - PUNTAS**

	<b>PHILLIPS®</b>	p. 452
	<b>POZIDRIV®</b>	p. 453
	<b>TORX®</b>	p. 454
	<b>TORX-PLUS®</b>	p. 455
	<b>ESAGONO</b>	p. 456
	<b>TAGLIO</b>	p. 457

**BUSSOLE - SOCKETS - DOUILLES - VASOS**

	<b>TORX®</b>	p. 458
	<b>ESAGONO</b>	p. 459
	<b>SISTEMA MULTI-IMPRONTA</b>	p. 460

**ATTACCHI - DRIVES - QUEUES - EMPALME**

		p. 461
---	--	--------



# SCHEDE TECNICHE

TECHNICAL DATASHEETS  
FICHES TECHNIQUES  
FICHAS TÉCNICAS

**PHILLIPS®**

A REGISTERED TRADEMARK OF PHILLIPS SCREW COMPANY



IN ACCORDO A NORME INTERNAZIONALI  
IN ACCORDANCE WITH INTERNATIONAL STANDARDS  
CONFORMÉMENT AUX NORMES INTERNATIONALES  
DE ACUERDO CON LAS NORMAS INTERNACIONALES

COPPIA DI TORSIONE SECONDO NORME  
TIGHTENING TORQUE IN ACCORDANCE WITH THE STANDARDS  
COUPLE DE TORSION SELON LES NORMES  
PAR DE TORSIÓN SEGÚN LAS NORMAS

**DIN 5260**  
**ISO 8764**

**DIN 5261\***  
**ISO 8764\***

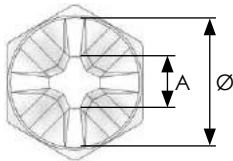

					Autofilettanti per metallo Self-tapping for metal Autotaraudeuses pour métal Tomillos de rosca chapa para metal			Autofilettanti per legno Self-tapping for wood Autotaraudeuses pour bois Tomillos de rosca chapa para madera			Metriche Metrics Métricas		
	A	Ø	 Nm	 Nm	ISO 7049 = DIN 7981	ISO 7050 = DIN 7982	ISO 7051 = DIN 7983	DIN 7996	DIN 7997	DIN 7995	ISO 7045 = DIN 7985	ISO 7046 = DIN 965	ISO 7047 = DIN 966
<b>PH0</b>	0,84	3	1,0	1,0	2,2	2,2	2,2	2,0	2,0	2,0	2,0	2,0	2,0
<b>PH1</b>	1,30	4,5	3,5	3,8	2,2 2,9	2,2 2,9	2,2 2,9	2,5 3,0	2,5 3,0	2,5 3,0	2,5 3,0	2,5 3,0	2,5 3,0
<b>PH2</b>	2,31	6	8,2	10,3	3,5 4,8	3,5 4,8	3,5 4,8	3,5 5,0	3,5 5,0	3,5 5,0	4,0 5,0	4,0 5,0	4,0 5,0
<b>PH3</b>	3,84	8	19,5	32,0	5,5 6,3	5,5 6,3	5,5 6,3	5,5 7,0	5,5 7,0	5,5 7,0	6,0	6,0	6,0
<b>PH4</b>	5,11	10	38,0	88,7	8,0 9,5	8,0 9,5	8,0 9,5	8,0	8,0	8,0	8,0 10,0	8,0 10,0	8,0 10,0

\* LE NORME PREVEDONO CHE SOTTO IL VALORE DI COPPIA INDICATA IL PROFILO DELL'UTENSILE NON PRESENTI ALCUNA DEFORMAZIONE

\* THE STANDARDS REQUIRE THAT THE TOOL PROFILE DOES NOT DEFORM UNDER THE INDICATED TORQUE VALUES

\* LES NORMES PRÉVOIENT QUE, SOUS LA VALEUR DU COUPLE INDIQUÉE, LE PROFIL DE L'OUTIL NE PRÉSENTE PAS DE DÉFORMATION

\* LAS NORMAS PREVÉN QUE POR DEBAJO DEL VALOR DE PAR DE TORSIÓN INDICADO, EL PERFIL DEL UTENSILIO NO PRESENTE NINGUNA DEFORMACIÓN

**POZIDRIV®**

A REGISTERED TRADEMARK OF PHILLIPS SCREW COMPANY



IN ACCORDO A NORME INTERNAZIONALI  
IN ACCORDANCE WITH INTERNATIONAL STANDARDS  
CONFORMÉMENT AUX NORMES INTERNATIONALES  
DE ACUERDO CON LAS NORMAS INTERNACIONALES

COPPIA DI TORSIONE SECONDO NORME  
TIGHTENING TORQUE IN ACCORDANCE WITH THE STANDARDS  
COUPLE DE TORSION SELON LES NORMES  
PAR DE TORSIÓN SEGÚN LAS NORMAS

**DIN 5260**  
**ISO 8764**

**DIN 5261\***  
**ISO 8764\***

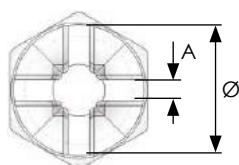

					Autofilettanti per metallo Self-tapping for metal Autotaraudeuses pour métal Tomillos de rosca chapa para metal			Autofilettanti per legno Self-tapping for wood Autotaraudeuses pour bois Tomillos de rosca chapa para madera			Metriche Metrics Métriques Métricas		
	A	Ø	 Nm	 Nm	ISO 7049 = DIN 7981	ISO 7050 = DIN 7982	ISO 7051 = DIN 7983	DIN 7996	DIN 7997	DIN 7995	ISO 7045 = DIN 7985	ISO 7046 = DIN 965	ISO 7047 = DIN 966
<b>PZ0</b>	0,45	3	1,0	1,0	2,2	2,2	2,2	2,0	2,0	2,0	2,0	2,0	2,0
<b>PZ1</b>	0,71	4,5	3,5	3,8	2,2 2,9	2,2 2,9	2,2 2,9	2,5 3,0	2,5 3,0	2,5 3,0	2,5 3,0	2,5 3,0	2,5 3,0
<b>PZ2</b>	1,00	6	8,2	10,3	3,5 4,8	3,5 4,8	3,5 4,8	3,5 5,0	3,5 5,0	3,5 5,0	4,0 5,0	4,0 5,0	4,0 5,0
<b>PZ3</b>	1,38	8	19,5	32,0	5,5 6,3	5,5 6,3	5,5 6,3	5,5 7,0	5,5 7,0	5,5 7,0	6,0	6,0	6,0
<b>PZ4</b>	2,10	10	38,0	88,7	8,0 9,5	8,0 9,5	8,0 9,5	8,0	8,0	8,0	8,0 10,0	8,0 10,0	8,0 10,0

\* LE NORME PREVEDONO CHE SOTTO IL VALORE DI COPPIA INDICATA IL PROFILO DELL'UTENSILE NON PRESENTI ALCUNA DEFORMAZIONE

\* THE STANDARDS REQUIRE THAT THE TOOL PROFILE DOES NOT DEFORM UNDER THE INDICATED TORQUE VALUES

\* LES NORMES PRÉVOIENT QUE, SOUS LA VALEUR DU COUPLE INDIQUÉE, LE PROFIL DE L'OUTIL NE PRÉSENTE PAS DE DÉFORMATION

\* LAS NORMAS PREVÉN QUE POR DEBAJO DEL VALOR DE PAR DE TORSIÓN INDICADO, EL PERFIL DEL UTENSILIO NO PRESENTE NINGUNA DEFORMACIÓN



# SCHEDE TECNICHE

TECHNICAL DATASHEETS  
FICHES TECHNIQUES  
FICHAS TÉCNICAS

**TORX®**

A REGISTERED TRADEMARK OF ACCUMENT GLOBAL TECHNOLOGIES



IN ACCORDO A NORME INTERNAZIONALI  
IN ACCORDANCE WITH INTERNATIONAL STANDARDS  
CONFORMÉMENT AUX NORMES INTERNATIONALES  
DE ACUERDO CON LAS NORMAS INTERNACIONALES

COPPIA DI TORSIONE SECONDO NORME  
TIGHTENING TORQUE IN ACCORDANCE WITH THE STANDARDS  
COUPLE DE TORSION SELON LES NORMES  
PAR DE TORSIÓN SEGÚN LAS NORMAS

**TMD-702**

**TMD-702\***

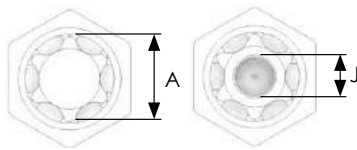

Autofilettanti per metallo Self-tapping for metal Autotaraudeuses pour métal Tornillos de rosca chapa para metal			Autofilettanti per legno Self-tapping for wood Autotaraudeuses pour bois Tornillos de rosca chapa para madera			Metriche Metrics Métricas					

Torx Symbol	A	J	Hand icon	Nm icon	Nm icon	Metal			Wood			Metric					
						ISO 7049 = DIN 7981	ISO 7050 = DIN 7982	ISO 7051 = DIN 7983	DIN 7996	DIN 7997	DIN 7995	ISO 7045 = DIN 7985	ISO 7046 = DIN 965	ISO 7047 = DIN 966	DIN 912 7984 6912	ISO 4762 = DIN 912	ISO 10642 = DIN 7991
TX03	1,12			0,25								1,2	1,4	1,4	1,2		
TX04	1,30			0,37													
TX05	1,37		0,43	0,51								1,4 1,6	1,8		1,4 1,6		
TX06	1,65		0,75	0,91		2,2	2,2					1,3 2,0	2,0		1,3 2,0		
TX07	1,97		1,4	1,7													
TX08	2,30	0,74	2,2	2,6	2,2	2,9	2,9	2,9				2,5	2,5	2,5		2,5	
TX09	2,48	0,81	2,8	3,4	2,9	2,9											
TX10	2,27	0,94	3,7	4,5	3,8	3,5	3,5	3,5	3,0	3,0		3,0	3,0	3,0	3,0	3,0	3,0
TX15	3,26	1,19	6,4	7,7	6,5	3,9	3,9	3,9	3,5	3,5		3,5	3,5	3,5	3,5		
TX20	3,84	1,57	10,5	12,7	10,8	4,2	4,2	4,2	4,0 4,5	4,0 4,5	4,5	4,0	4,0	4,0	4,0	4,0	4,0
TX25	4,40	1,96	15,9	19,0	16,1	4,8 5,5	4,8 5,5	4,8 5,5	4,5 6,0	4,5 5,0	4,5	5,0	5,0	5,0	4,0 5,0	5,0	5,0
TX27	4,96	2,21	22,5	26,9	22,9										4,3 5,0		
TX30	5,49	2,72	31,1	37,4	31,8	6,3	6,3	6,3	6,0	6,0		6,0	6,0	6,0	6,0	6,0	6,0
TX40	6,60	3,15	54,1	65,1	55,3	8,0				8,0 10,0		8,0	8,0	8,0	8,0		8,0
TX45	7,77	3,40	86,0	104,0	88,0											8,0	
TX50	8,79	3,73	132,0	159,0	135,0	10,0						10,0	10,0	10,0	10,0	10,0	10,0
TX55	11,17	4,75		257,0	218,0	12,0									12,0	12,0	
TX60	13,20	5,56		445,0	379,0										14,0	14,0	
TX70	15,49	6,73		701,0	596,0												

\* PER QUESTO PROFILO I VALORI DI COPPIA INDICATI CORRISPONDONO AL VALORE MINIMO DI ROTTURA

\* THE TORQUE VALUES INDICATED FOR THIS PROFILE CORRESPOND TO THE MINIMUM BREAKING VALUE

\* POUR CE PROFIL, LES VALEURS DE COUPLE INDICUÉES CORRESPONDENT À LA VALEUR MINIMALE DE RUPTURE

\* PARA ESTE PERFIL LOS VALORES DE PAR DE TORSIÓN INDICADOS CORRESPONDEN AL VALOR MÍNIMO DE RUPTURA

**TORX-PLUS®**
**TORX-PLUS® TAMPER RESISTANT**

A REGISTERED TRADEMARK OF ACCUMENT GLOBAL TECHNOLOGIES

 IN ACCORDO A NORME INTERNAZIONALI  
 IN ACCORDANCE WITH INTERNATIONAL STANDARDS  
 CONFORMÉMENT AUX NORMES INTERNATIONALES  
 DE ACUERDO CON LAS NORMAS INTERNACIONALES

 COPPIA DI TORSIONE SECONDO NORME  
 TIGHTENING TORQUE IN ACCORDANCE WITH THE STANDARDS  
 COUPLE DE TORSION SELON LES NORMES  
 PAR DE TORSIÓN SEGÚN LAS NORMAS

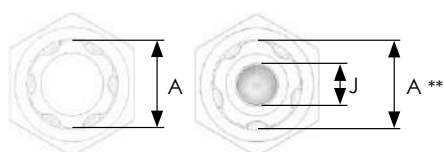
**NMD-702**  
**NMD-602**
**NMD-702\***  
**NMD-602\***

 \*\* DIAMETRO CIRCOSCRITTO • \*\* CIRCUMSCRIBED DIAMETER •  
 \*\* DIAMÈTRE CIRCONSCRIT • \*\* DIÁMETRO CIRCUNSCRITO

Autofilettanti per metallo Self-tapping for metal Autotaraudeuses pour métal Tornillos de rosca chapa para metal			Metriche Metrics Métriques Métricas						

	A	Nm		A	J	Nm	ISO 7049 = DIN 7981	ISO 7050 = DIN 7982	ISO 7051 = DIN 7983	ISO 7045 = DIN 7985	ISO 7046 = DIN 965	ISO 7047 = DIN 966	DIN 912 = 7984 = 6912	ISO 4762 = DIN 912	ISO 10642 = DIN 7991
<b>10IP</b>	2,72	5,42	<b>10IPR</b>	2,72	0,91	4,3	3,5	3,5	2,9 3,5	3,0	3,0	3,0	3,0	3,0	5,0
<b>15IP</b>	3,25	9,62	<b>15IPR</b>	3,25	1,17	7,3	3,9	3,9	3,5 3,9	3,5	3,5 4,0	3,5			6,0
<b>20IP</b>	3,84	16,15	<b>20IPR</b>	3,84	1,55	11,9	4,2	4,2	4,2	4,0	4,0 5,0	4,0	4,0	4,0	6,0
<b>25IP</b>	4,39	23,50	<b>25IPR</b>	4,39	1,93	17,4	4,8 5,5	4,8 5,5	4,8 5,5	5,0	5,0 6,0	5,0	5,0	5,0	7,0 8,0
<b>27IP</b>	4,95	34,62	<b>27IPR</b>	4,95	2,18	25,1									8,0
<b>30IP</b>	5,49	47,18	<b>30IPR</b>	5,49	2,57	33,5	6,3	6,3	6,3	6,0	6,0	6,0	8,0	6,0	
<b>40IP</b>	6,60	82,08	<b>40IPR</b>	6,60	2,92	59,4			8,0		8,0	8,0	8,0	8,0	10,0

\* PER QUESTO PROFILO I VALORI DI COPPIA INDICATI CORRISPONDONO AL VALORE MINIMO DI ROTTURA

\* THE TORQUE VALUES INDICATED FOR THIS PROFILE CORRESPOND TO THE MINIMUM BREAKING VALUE

\* POUR CE PROFIL, LES VALEURS DE COUPLE INDIQUÉES CORRESPONDENT À LA VALEUR MINIMALE DE RUPTURE

\* PARA ESTE PERFIL LOS VALORES DE PAR DE TORSIÓN INDICADOS CORRESPONDEN AL VALOR MÍNIMO DE RUPTURA



# SCHEDE TECNICHE

TECHNICAL DATASHEETS  
FICHES TECHNIQUES  
FICHAS TÉCNICAS

## ESAGONO



IN ACCORDO A NORME INTERNAZIONALI  
IN ACCORDANCE WITH INTERNATIONAL STANDARDS  
CONFORMÉMENT AUX NORMES INTERNATIONALES  
DE ACUERDO CON LAS NORMAS INTERNACIONALES

COPPIA DI TORSIONE SECONDO NORME  
TIGHTENING TORQUE IN ACCORDANCE WITH THE STANDARDS  
COUPLE DE TORSION SELON LES NORMES  
PAR DE TORSIÓN SEGÚN LAS NORMAS

**DIN 911**  
**DIN 7426**

**DIN 7426\***  
**ISO 2936\***

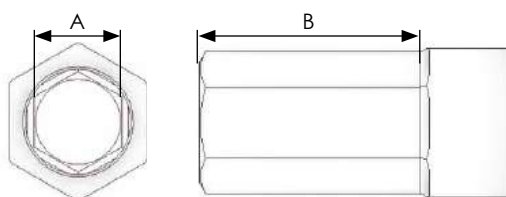

○	A	B <sub>MIN</sub>	✋ Nm	🔧 Nm	Metriche Metrics Métriques Métricas				
<b>0,7</b>	0,7	1,6	0,08		DIN 7984	ISO 4762 = DIN 7984	ISO 10642 = DIN 7991	DIN 908	DIN 913 914 DIN 915 916
<b>0,9</b>	0,9	1,8	0,18						1,4 1,8
<b>1,3</b>	1,3	2,0	0,53			1,4			2,0
<b>1,5</b>	1,5	2,3	0,82	0,95		1,6 2,0			2,5
<b>2,0</b>	2,0	3,0	1,9	2,3	3,0	2,5	3,0		3,0
<b>2,5</b>	2,5	3,8	3,4	4,4	4,0	3,0	4,0		4,0
<b>3,0</b>	3,0	4,5	6,6	7,6	5,0	4,0	5,0		5,0
<b>4,0</b>	4,0	6,0	16,0	18,0	6,0	5,0	6,0		6,0
<b>5,0</b>	5,0	7,5	30,0	35,0	8,0	6,0	8,0	10,0	10,0
<b>6,0</b>	6,0	9,0	52,0	61,0		8,0	10,0	12,0 14,0	12,0 14,0
<b>7,0</b>	7,0	10,5	78,0	97,0	10,0				
<b>8,0</b>	8,0	12,0	120,0	140,0	12,0	10,0	12,0	16,0 18,0	16,0 18,0
<b>10,0</b>	10,0	16,0	220,0	280,0	14,0	12,0	14,0 16,0	20,0 22,0	20,0 22,0
<b>12,0</b>	12,0	18,0	370,0	480,0	16,0 18,0	14,0	18,0 20,0	24,0 26,0	24,0 26,0
<b>14,0</b>	14,0	25,0	590,0		20,0 22,0	16,0 18,0	22,0 24,0		

\* LE NORME PREVEDONO CHE SOTTO IL VALORE DI COPPIA INDICATA IL PROFILO DELL'UTENSILE NON PRESENTI ALCUNA DEFORMAZIONE

\* THE STANDARDS REQUIRE THAT THE TOOL PROFILE DOES NOT DEFORM UNDER THE INDICATED TORQUE VALUES

\* LES NORMES PRÉVOIENT QUE, SOUS LA VALEUR DU COUPLE INDIQUÉE, LE PROFIL DE L'OUTIL NE PRÉSENTE PAS DE DÉFORMATION

\* LAS NORMAS PREVÉN QUE POR DEBAJO DEL VALOR DE PAR DE TORSIÓN INDICADO, EL PERFIL DEL UTENSILIO NO PRESENTE NINGUNA DEFORMACIÓN



# TAGLIO



IN ACCORDO A NORME INTERNAZIONALI  
IN ACCORDANCE WITH INTERNATIONAL STANDARDS  
CONFORMÉMENT AUX NORMES INTERNATIONALES  
DE ACUERDO CON LAS NORMAS INTERNACIONALES

COPPIA DI TORSIONE SECONDO NORME  
TIGHTENING TORQUE IN ACCORDANCE WITH THE STANDARDS  
COUPLE DE TORSION SELON LES NORMES  
PAR DE TORSIÓN SEGÚN LAS NORMAS

## DIN-ISO 2380

## DIN-ISO 2380\*

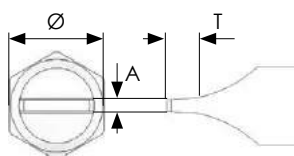

Autofilettanti per metallo Self-tapping for metal Autotaraudeuses pour métal Tornillos de rosca chapa para metal			Autofilettanti per legno Self-tapping for wood Autotaraudeuses pour bois Tornillos de rosca chapa para madera			Metriche Metrics Métriques Métricas									
Ø	A	T	Nm	Nm	ISO 1481 = DIN 7971	ISO 1482 = DIN 7972	ISO 1483 = DIN 7973	DIN 96	DIN 97	DIN 95	ISO 1207 = DIN 84	ISO 1580 = DIN 85	ISO 2009 = DIN 963	ISO 2010 = DIN 964	ISO 4766 = 7435 = DIN 417-427

Ø	A	T	Nm	Nm	ISO 1481 = DIN 7971	ISO 1482 = DIN 7972	ISO 1483 = DIN 7973	DIN 96	DIN 97	DIN 95	ISO 1207 = DIN 84	ISO 1580 = DIN 85	ISO 2009 = DIN 963	ISO 2010 = DIN 964	ISO 4766 = 7435 = DIN 417-427
1,5	0,30	0,50		0,15											
1,8	0,37	0,50		0,28							1,2 1,4				
2,0	0,40	0,70	0,3	0,35				1,6	1,6				1,6		2,5 3,0
2,5	0,40	0,70	0,4	0,45				2,0		1,6	1,6 1,8			1,6	3,5
3,0	0,50	0,90	0,7	0,8		2,2	2,2		2,0	2,0	2,0		2,0	2,0	4,0
3,5	0,60	1,10	1,3	1,4	2,2			2,5	2,5	2,5	2,5		2,5	2,5	
4,0	0,50	0,90		1,1				2,0							
4,0	0,80	1,40	2,6	2,9	2,9	2,9	2,9	3,0 3,5	3,0 3,5	3,0 3,5	3,0	3,0	3,0 3,5	3,0 3,5	5,0 6,0
4,5	0,60	1,10		1,8	2,2			2,5			2,5				
5,0	0,80	1,40	3,2	3,6											
5,5	0,80	1,40	3,5	3,9				3,5		3,5	3,0	3,5	3,5	3,5	
5,5	1,00	1,80	5,5	6,2	3,5 3,9	3,5 3,9	3,5 3,9	4,0 4,5	4,0 4,5	4,0 4,5	3,5	3,5	4,0	4,0	
6,0	1,00	1,80		6,7											
6,5	1,20	2,20	9,4	10,5		4,2 4,8	4,2	5,0 5,5	5,0	5,0	4,0		5,0	5,0	8,0
7,0	1,20	2,20	10,0	11,3											
8,0	1,20	2,20	11,5	12,9	4,2		4,8		5,5	5,5	5,0	4,0			
8,0	1,60	2,90	20,5	22,9	4,8	5,5 6,3	5,5	6,0	6,0	6,0		5,0	6,0	6,0	10,0 12,0
10,0	1,60	2,90	25,6	28,7	5,5 6,3		6,3		7,0 8,0	7,0	6,0				14,0
13,0	2,00	3,60	52,0	58,0				8,0	10,0		8,0	8,0	8,0	8,0	16,0

\* LE NORME PREVEDONO CHE SOTTO IL VALORE DI COPPIA INDICATA IL PROFILO DELL'UTENSILE NON PRESENTI ALCUNA DEFORMAZIONE

\* THE STANDARDS REQUIRE THAT THE TOOL PROFILE DOES NOT DEFORM UNDER THE INDICATED TORQUE VALUES

\* LES NORMES PRÉVOIENT QUE, SOUS LA VALEUR DU COUPLE INDIQUÉE, LE PROFIL DE L'OUTIL NE PRÉSENTE PAS DE DÉFORMATION

\* LAS NORMAS PREVÉN QUE POR DEBAJO DEL VALOR DE PAR DE TORSIÓN INDICADO, EL PERFIL DEL UTENSILIO NO PRESENTE NINGUNA DEFORMACIÓN



# SCHEDE TECNICHE

TECHNICAL DATASHEETS  
FICHES TECHNIQUES  
FICHAS TÉCNICAS

**TORX®**

A REGISTERED TRADEMARK OF ACCUMENT GLOBAL TECHNOLOGIES



IN ACCORDO A SPECIFICA ACCUMENT GLOBAL TECHNOLOGIES  
IN ACCORDANCE WITH THE SPECIFICATIONS OF ACCUMENT GLOBAL TECHNOLOGIES  
CONFORMÉMENT À LA SPÉCIFICATION D'ACCUMENT GLOBAL TECHNOLOGIES  
DE ACUERDO CON LAS ESPECIFICACIONES DE ACCUMENT GLOBAL TECHNOLOGIES



Metrice  
Metrics  
Métriques  
Métricas



	A	ISO 4014 - 4017 = DIN 931 - 933	ISO 8100 = DIN 6921
	A		
<b>E5</b>	4,72	4,0	
<b>E6</b>	5,69	5,0	4,0
<b>E7</b>	6,17		
<b>E8</b>	7,47	6,0 7,0	5,0
<b>E10</b>	9,37	8,0	6,0
<b>E11</b>	10,03		
<b>E12</b>	11,12	10,0 11,0	8,0
<b>E14</b>	12,85	12,0	10,0
<b>E16</b>	14,71		
<b>E18</b>	16,64	14,0	12,0
<b>E20</b>	18,41	16,0	14,0
<b>E22</b>	20,24		
<b>E24</b>	22,09	18,0 20,0	

# ESAGONO



IN ACCORDO A NORME INTERNAZIONALI  
IN ACCORDANCE WITH INTERNATIONAL STANDARDS  
CONFORMÉMENT AUX NORMES INTERNATIONALES  
DE ACUERDO CON LAS NORMAS INTERNACIONALES

COPPIA DI TORSIONE SECONDO NORME  
TIGHTENING TORQUE IN ACCORDANCE WITH THE STANDARDS  
COUPLE DE TORSION SELON LES NORMES  
PAR DE TORSIÓN SEGÚN LAS NORMAS

**DIN 3129**

**DIN-ISO 1711\***

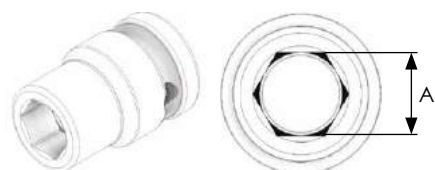

Autofilettanti per metallo Self-tapping for metal Autotaraudeuses pour métal Tomillos de rosca chapa para metal	Autofilettanti per legno Self-tapping for wood Autotaraudeuses pour bois Tomillos de rosca chapa para madera	Metriche Metrics Métriques Métricas		

Ø	 Nm	 Nm	ISO 1479 = DIN 7976	DIN 571	ISO 4014 4016 4017	ISO 4035 4036 = DIN 439	ISO 4032 4033 = DIN 934
<b>4</b>		10,4			2,0	2,0	2,0
<b>4,5</b>		12,6			2,3		
<b>5</b>	11,5	15,1	2,9		2,5	2,5	2,5
<b>5,5</b>	14,4	17,8	3,5		3,0	3,0	3,0
<b>6</b>	17,6	23,2			3,5	3,5	3,5
<b>7</b>	25,2	33,2	3,9 4,2	4,0	4,0	4,0	4,0
<b>8*</b>	34,5	94,1	4,8 5,5	5,0	5,0	5,0	5,0
<b>9*</b>	45,4	119,2					
<b>10*</b>	58,1	147,0	6,3	6,0	6,0	6,0	6,0
<b>11*</b>	72,7	178,0			7,0		7,0
<b>12*</b>	89,1	212,0		7,0			
<b>13*</b>	107,0	249,0	8,0	8,0	8,0	8,0	8,0
<b>14*</b>	128,0	288,0					

\* VALUTARE ANCHE RESISTENZA ATTACCO

\* ALSO EVALUATE ATTACHMENT RESISTANCE

\* ÉVALUER LA RÉSISTANCE DU RACCORD

\* CONSIDERAR TAMBIÉN LA RESISTENCIA DEL EMPALME



# SCHEDE TECNICHE

TECHNICAL DATASHEETS

FICHES TECHNIQUES







FICHAS TÉCNICAS

## SISTEMA MULTI-IMPRONTA

## SPLINE SOCKET SYSTEM











































ADATTO A VARIE IMPRONTE: ESAGONALE, ESAGONALE IN POLLICI, POLIGONALE, TORX (E), QUADRO  
 SUITABLE TO VARIOUS TIPS: HEXAGONAL, HEX (INCHES), POLYGONAL, TORX (E), SQUARE  
 ADAPTE À DIVERSES EMPREINTES : HEXAGONALE, HEXAGONALE (POUCES), POLYGONALE, TORX (E) CARRÉE  
 ADAPTO A VARIAS HUELLAS: HEXAGONALES, HEX (PULGADAS), POLIGONAL, TORX (E) Y CUADRADA

					
4	4	5/32"	4	E5	
4,5	4,5		4,5	E6	
5	5		5		4
5,5	5,5	7/32"	5,5		
6	6		6	E8	6
7	7		7		6
8	8	5/16"	8	E10	
9	9		9		7
10	10	3/8"	10	E12	8
11	11	7/16"	11	E14	9
12	12	15/32"	12	E16	10
13	13	1/2"	13		11
14	14		14	E18	
15	15	19/32"	15		
16	16	5/8"	16	E20	13
17	17		17		14
18	18		18	E22	15
19	19	3/4"	19	E24	16
20	20	25/32"	20		17
21	21	13/16"	21		
22	22	7/8"	22		18
23	23		23		
24	24	15/16"	24		20
27	27	1-1/16"	27		22
30	30	1-3/16"	30		25
32	32	1-1/4"	32		26

## ATTACCHI MASCHIO STANDARD, APPLICAZIONI, RESISTENZE

STANDARD MALE ATTACHMENTS, APPLICATIONS, RESISTANCES  
 QUEUES MÂLES STANDARD, APPLICATIONS, RÉISTANCES  
 EMPALMES MACHO ESTÁNDAR, APLICACIONES Y RESISTENCIAS

			APPLICAZIONE application application aplicación	STANDARDS	Nm
	A=3mm			DIN 3126 Form A3	7,6
	A=4mm - 5/32"			DIN 3126 Form C4	18,0
	A=5,5mm			DIN 3126 Form A5,5	47,0
	B=VARIE			LTI	N.A.
	B=7mm			LTI	N.A.
	A=6,35mm - 1/4"			DIN 3126 Form C6,3	71,0
	A=6,35mm - 1/4"			DIN 3126 Form E6,3	71,0
	A=7,93mm - 5/16"			DIN 3126 Form C8	144,0
	A=7,93mm - 5/16"			FIAM-DESOUTTER	144,0
	A=9,52mm - 3/8"			AUTOMOTIVE	280,0
	A=11,2mm - 7/16"			DIN 3126 Form E11,2	396,0
	B=M4x0,7			ISO 724 - DIN 13.1	7,0
	B=M5x0,8			ISO 724 - DIN 13.1	18,0
	B=M6x1			ISO 724 - DIN 13.1	25,0
	B=10x32 UNF			ISO 724 - DIN 13.1	18,0
	B=BSF 3/16x32 Whitworth			ISO 724 - DIN 13.1	18,0







# SCHEDE TECNICHE

TECHNICAL DATASHEETS  
FICHES TECHNIQUES  
FICHAS TÉCNICAS

## ATTACCHI QUADRO STANDARD, APPLICAZIONI, RESISTENZE

STANDARD SQUARE ATTACHMENTS, APPLICATIONS, RESISTANCES  
RACCORDI CARRÉS STANDARD, APPLICATIONS, RÉSISTANCES  
EMPALMES CUADRADOS ESTÁNDAR, APLICACIONES Y RESISTENCIAS

			APPLICAZIONE application application aplicación	STANDARDS	Nm
	A=6,35mm - 1/4"			DIN 3121 Form G6,3	68,6
	A=9,52mm - 3/8"			DIN 3121 Form G10	225,0
	A=12,70mm - 1/2"			DIN 3121 Form G12,5	569,0
	A=19,05mm - 3/4"			DIN 3121 Form H20	1569,0
	A=25,40mm - 1"			DIN 3121 Form H25	2795,0
	A=38,10mm - 1-1/2"			DIN 3121 Form H40	

			APPLICAZIONE application application aplicación	STANDARDS	Nm
	A=6,35mm - 1/4"			DIN 3121 Form G6,3	62,0
	A=9,52mm - 3/8"			DIN 3121 Form G10	202,0
	A=12,70mm - 1/2"			DIN 3121 Form G12,5	512,0
	A=19,05mm - 3/4"			DIN 3121 Form D20	1412,0



*Magazzino di stoccaggio e produzione LTI in sito Krino.*

*LTI customized products stock in Krino site.*

*Stocage produits specials LTI dans le batement Krino.*

*Estock de productos especiales LTI en la nave Krino.*

# INDICE PER CODICE PROGRESSIVO

INDEX FOR PROGRESSIVE CODES  
INDEX POUR CODE PROGRESSIF  
ÍNDICE PARA CÓDIGO PROGRESIVO

<b>61001</b>	p. 150	<b>61059</b>	p. 65	<b>61122</b>	p. 161
<b>61002</b>	p. 153	<b>61060</b>	p. 125	<b>61123</b>	p. 148
<b>61003</b>	p. 153	<b>61061</b>	p. 256	<b>61124</b>	p. 163
<b>61004</b>	p. 152	<b>61062</b>	p. 258	<b>61125</b>	p. 162
<b>61006</b>	p. 151	<b>61063</b>	p. 260	<b>61126</b>	p. 148
<b>61007</b>	p. 152	<b>61064</b>	p. 264	<b>61127</b>	p. 240
<b>61008</b>	p. 245	<b>61065</b>	p. 262	<b>61128</b>	p. 240
<b>61010</b>	p. 266	<b>61066</b>	p. 268	<b>61129</b>	p. 238
<b>61011</b>	p. 238	<b>61067</b>	p. 166	<b>61132</b>	p. 164
<b>61012</b>	p. 265	<b>61068</b>	p. 269	<b>61133</b>	p. 160
<b>61021</b>	p. 154	<b>61069</b>	p. 138	<b>61134</b>	p. 160
<b>61022</b>	p. 156	<b>61070</b>	p. 140	<b>61135</b>	p. 161
<b>61023</b>	p. 155	<b>61071</b>	p. 102	<b>61136</b>	p. 163
<b>61024</b>	p. 245	<b>61072</b>	p. 140	<b>61137</b>	p. 162
<b>61025</b>	p. 156	<b>61073</b>	p. 141	<b>61138</b>	p. 164
<b>61026</b>	p. 103	<b>61075</b>	p. 138	<b>61139</b>	p. 147
<b>61027</b>	p. 167	<b>61076</b>	p. 139	<b>61140</b>	p. 249
<b>61028</b>	p. 167	<b>61077</b>	p. 244	<b>61142</b>	p. 249
<b>61029</b>	p. 158	<b>61078</b>	p. 102	<b>61143</b>	p. 249
<b>61030</b>	p. 159	<b>61080</b>	p. 266	<b>61144</b>	p. 250
<b>61031</b>	p. 268	<b>61081</b>	p. 126	<b>61146</b>	p. 250
<b>61035</b>	p. 256	<b>61082</b>	p. 141	<b>61147</b>	p. 165
<b>61036</b>	p. 258	<b>61083</b>	p. 66	<b>61200</b>	p. 54
<b>61037</b>	p. 260	<b>61084</b>	p. 66	<b>61201</b>	p. 54
<b>61038</b>	p. 264	<b>61085</b>	p. 126	<b>61210</b>	p. 51
<b>61039</b>	p. 262	<b>61090</b>	p. 262	<b>61211</b>	p. 51
<b>61040</b>	p. 268	<b>61091</b>	p. 256	<b>61220</b>	p. 52
<b>61041</b>	p. 166	<b>61092</b>	p. 259	<b>61221</b>	p. 52
<b>61042</b>	p. 269	<b>61093</b>	p. 260	<b>61230</b>	p. 53
<b>61043</b>	p. 132	<b>61094</b>	p. 142	<b>61231</b>	p. 53
<b>61044</b>	p. 135	<b>61095</b>	p. 103	<b>61250</b>	p. 77
<b>61045</b>	p. 101	<b>61097</b>	p. 143	<b>61251</b>	p. 77
<b>61046</b>	p. 132	<b>61099</b>	p. 246	<b>61260</b>	p. 78
<b>61047</b>	p. 135	<b>61100</b>	p. 239	<b>61261</b>	p. 78
<b>61048</b>	p. 136	<b>61101</b>	p. 146	<b>61270</b>	p. 79
<b>61049</b>	p. 125	<b>61102</b>	p. 146	<b>61271</b>	p. 79
<b>61051</b>	p. 133	<b>61103</b>	p. 67	<b>61305</b>	p. 91
<b>61052</b>	p. 101	<b>61104</b>	p. 67	<b>61310</b>	p. 89
<b>61053</b>	p. 244	<b>61110</b>	p. 258	<b>61311</b>	p. 89
<b>61055</b>	p. 266	<b>61111</b>	p. 144	<b>61320</b>	p. 90
<b>61056</b>	p. 136	<b>61113</b>	p. 145	<b>61321</b>	p. 90
<b>61057</b>	p. 137	<b>61114</b>	p. 239	<b>61330</b>	p. 91
<b>61058</b>	p. 65	<b>61121</b>	p. 149	<b>61355</b>	p. 31



<b>61356</b>		p. 31	<b>62016025</b>		p. 202	<b>62063</b>		p. 247
<b>61365</b>		p. 32	<b>62016030</b>		p. 202	<b>62064</b>		p. 248
<b>61366</b>		p. 32	<b>62016035</b>		p. 202	<b>62068</b>		p. 267
<b>61375</b>		p. 33	<b>62016105</b>		p. 203	<b>62081</b>		p. 241
<b>61376</b>		p. 33	<b>62016999</b>		p. 210	<b>62082</b>		p. 241
<b>61400</b>		p. 114	<b>62017</b>		p. 206	<b>62083</b>		p. 241
<b>61405</b>		p. 115	<b>62018</b>	<b>62018005</b>	p. 201	<b>62085</b>		p. 265
<b>61410</b>		p. 113		<b>62018010</b>	p. 202	<b>62086</b>		p. 207
<b>61420</b>		p. 113	<b>62019</b>	<b>62019010</b>	p. 204	<b>62100</b>		p. 227
<b>61430</b>		p. 114		<b>62019015</b>	p. 205	<b>62101</b>		p. 227
<b>61450</b>		p. 39		<b>62019020</b>	p. 205	<b>62102</b>		p. 230
<b>61451</b>		p. 39		<b>62019030</b>	p. 203	<b>62103</b>		p. 229
<b>61460</b>		p. 40		<b>62019033</b>	p. 203	<b>62104</b>	<b>62104001</b>	p. 337
<b>61461</b>		p. 40		<b>62019035</b>	p. 203		<b>62104005</b>	p. 287
<b>61470</b>		p. 41	<b>62020</b>	<b>62020005</b>	p. 206		<b>62104010</b>	p. 287
<b>61471</b>		p. 41		<b>62020010</b>	p. 206	<b>62111</b>		p. 228
<b>62001</b>	<b>62001005</b>	p. 254		<b>62020015</b>	p. 207	<b>62112</b>		p. 230
	<b>62001010</b>	p. 254	<b>62022</b>		p. 211	<b>62113</b>		p. 229
	<b>62001015</b>	p. 255	<b>62023</b>		p. 215	<b>62114</b>		p. 230
	<b>62001100</b>	p. 255	<b>62024</b>		p. 211	<b>62115</b>	<b>62115001</b>	p. 327
<b>62005</b>		p. 257	<b>62025</b>		p. 215		<b>62115005</b>	p. 281
<b>62006</b>		p. 259	<b>62027</b>		p. 216	<b>62116</b>	<b>62116001</b>	p. 351
<b>62007</b>		p. 261	<b>62028</b>		p. 217		<b>62116005</b>	p. 296
<b>62008</b>		p. 264	<b>62029</b>	<b>62029005</b>	p. 214		<b>62116010</b>	p. 296
<b>62009</b>		p. 263		<b>62029010</b>	p. 214		<b>62116015</b>	p. 296
<b>62011</b>		p. 211		<b>62029015</b>	p. 221		<b>62116020</b>	p. 296
<b>62012</b>		p. 200		<b>62029030</b>	p. 214		<b>62116025</b>	p. 296
<b>62013</b>		p. 199	<b>62030</b>		p. 217	<b>62121</b>		p. 228
<b>62014</b>		p. 210	<b>62031</b>		p. 218	<b>62122</b>	<b>62122005</b>	p. 229
<b>62015</b>	<b>62015005</b>	p. 199	<b>62032</b>		p. 213		<b>62122101</b>	p. 275
	<b>62015010</b>	p. 199	<b>62033</b>		p. 213	<b>62124</b>	<b>62124001</b>	p. 337
	<b>62015015</b>	p. 199	<b>62034</b>	<b>62034006</b>	p. 223		<b>62124005</b>	p. 287
	<b>62015020</b>	p. 199		<b>62034010</b>	p. 223		<b>62124010</b>	p. 287
	<b>62015025</b>	p. 199		<b>62034015</b>	p. 225	<b>62126</b>		p. 310
	<b>62015030</b>	p. 199		<b>62034020</b>	p. 224	<b>62135</b>	<b>62135001</b>	p. 351
	<b>62015035</b>	p. 199		<b>62034025</b>	p. 225		<b>62135005</b>	p. 296
	<b>62015040</b>	p. 199	<b>62035</b>		p. 201	<b>62137</b>		p. 315
	<b>62015070</b>	p. 199	<b>62036</b>		p. 204	<b>62141</b>		p. 310
	<b>62015105</b>	p. 200	<b>62042</b>		p. 269	<b>62142</b>		p. 317
<b>62016</b>	<b>62016005</b>	p. 202	<b>62051</b>		p. 221	<b>62145</b>		p. 315
	<b>62016010</b>	p. 202	<b>62053</b>		p. 224	<b>62151</b>		p. 274
	<b>62016015</b>	p. 202	<b>62054</b>		p. 221	<b>62152</b>		p. 274
	<b>62016020</b>	p. 202	<b>62055</b>		p. 220	<b>62155</b>		p. 272



# INDICE PER CODICE PROGRESSIVO

INDEX FOR PROGRESSIVE CODES  
INDEX POUR CODE PROGRESSIF  
ÍNDICE PARA CÓDIGO PROGRESIVO

<b>62171</b>	p. 281	<b>63600</b>	<b>63600001</b>	p. 194	<b>64137</b>	p. 293	
<b>62172</b>	p. 281		<b>63600005</b>	p. 194	<b>64139</b>	p. 308	
<b>62173</b>	p. 326		<b>63600016</b>	p. 195	<b>64145</b>	p. 325	
<b>62174</b>	p. 326	<b>64001</b>		p. 279	<b>64147</b>	p. 324	
<b>62180</b>	p. 275	<b>64003</b>		p. 280	<b>64148</b>	p. 325	
<b>62181</b>	p. 286	<b>64005</b>		p. 279	<b>64149</b>	p. 323	
<b>62182</b>	p. 287	<b>64007</b>		p. 280	<b>64150</b>	p. 323	
<b>62183</b>	p. 286	<b>64008</b>		p. 321	<b>64151</b>	p. 324	
<b>62184</b>	p. 286	<b>64009</b>		p. 322	<b>64161</b>	p. 332	
<b>62185</b>	p. 336	<b>64011</b>		p. 282	<b>64162</b>	p. 333	
<b>62186</b>	p. 336	<b>64013</b>		p. 283	<b>64163</b>	p. 332	
<b>62191</b>	p. 294	<b>64015</b>		p. 284	<b>64171</b>	p. 341	
<b>62192</b>	p. 295	<b>64017</b>		p. 284	<b>64172</b>	p. 342	
<b>62193</b>	p. 294	<b>64026</b>		p. 330	<b>64173</b>	p. 343	
<b>62194</b>	p. 294	<b>64027</b>		p. 331	<b>64174</b>	p. 346	
<b>62195</b>	p. 350	<b>64031</b>		p. 288	<b>64175</b>	p. 344	
<b>62196</b>	p. 350	<b>64033</b>		p. 289	<b>64176</b>	p. 345	
<b>62197</b>	p. 295	<b>64035</b>		p. 290	<b>64177</b>	<b>64177001</b>	p. 347
<b>62205</b>	p. 308	<b>64040</b>		p. 290		<b>64177002</b>	p. 347
<b>62206</b>	p. 309	<b>64048</b>		p. 340		<b>64177005</b>	p. 347
<b>62207</b>	p. 309	<b>64049</b>		p. 340		<b>64177006</b>	p. 347
<b>62211</b>	p. 314	<b>64061</b>		p. 306		<b>64177011</b>	p. 348
<b>62212</b>	p. 314	<b>64063</b>		p. 307		<b>64177012</b>	p. 348
<b>62215</b>	p. 317	<b>64071</b>		p. 312		<b>64177015</b>	p. 348
<b>62216</b>	p. 317	<b>64072</b>		p. 313		<b>64177016</b>	p. 348
<b>62601</b>	p. 231	<b>64081</b>		p. 316		<b>64177021</b>	p. 349
<b>62602</b>	p. 354	<b>64101</b>		p. 298		<b>64177022</b>	p. 349
<b>63001</b>	p. 190	<b>64102</b>		p. 299		<b>64177025</b>	p. 349
<b>63002</b>	p. 188	<b>64103</b>		p. 301		<b>64177026</b>	p. 349
<b>63003</b>	p. 191	<b>64104</b>		p. 301	<b>64181</b>		p. 292
<b>63004</b>	p. 188	<b>64105</b>		p. 302	<b>64182</b>		p. 293
<b>63005</b>	p. 192	<b>64106</b>		p. 303	<b>64183</b>		p. 292
<b>63006</b>	p. 189	<b>64107</b>		p. 305	<b>64184</b>		p. 292
<b>63008</b>	p. 267	<b>64108</b>		p. 305	<b>64185</b>		p. 293
<b>63010</b>	p. 189	<b>64109</b>		p. 300	<b>64198</b>		p. 334
<b>63011</b>	p. 193	<b>64110</b>		p. 304	<b>64199</b>		p. 335
<b>63012</b>	p. 192	<b>64125</b>		p. 284	<b>64200</b>		p. 335
<b>63014</b>	p. 273	<b>64126</b>		p. 290	<b>64201</b>		p. 334
<b>63015</b>	p. 270	<b>64131</b>		p. 285	<b>64202</b>		p. 334
<b>63016</b>	p. 270	<b>64132</b>		p. 285	<b>64220</b>		p. 327
<b>63021</b>	p. 271	<b>64133</b>		p. 285	<b>64221</b>	<b>64221001</b>	p. 395
<b>63022</b>	p. 271	<b>64135</b>		p. 291		<b>64221005</b>	p. 328
<b>63025</b>	p. 272	<b>64136</b>		p. 291		<b>64221006</b>	p. 328

	64221010	p. 329		65006015	p. 384		65101	65101001	p. 408
	64221015	p. 329		65006020	p. 384			65101002	p. 409
	64221020	p. 212-328		65006030	p. 393			65101003	p. 411
	64221030	p. 212		65006031	p. 393			65101011	p. 408
<b>64222</b>		p. 338		65006035	p. 392			65101012	p. 409
<b>64223</b>	64223005	p. 338		65006036	p. 392			65101013	p. 411
	64223006	p. 338		65006041	p. 399			65101014	p. 412
	64223010	p. 339		65006042	p. 398			65101015	p. 410
	64223015	p. 339		65006045	p. 394			65101016	p. 414
<b>64224</b>	64224001	p. 352		65006046	p. 394			65101017	p. 415
	64224005	p. 352		65006047	p. 395			65101031	p. 408
	64224006	p. 352		65006050	p. 396			65101032	p. 409
	64224010	p. 353		65006055	p. 397			65101033	p. 411
	64224015	p. 353		65006185	p. 388			65101034	p. 413
<b>64230</b>	64230005	p. 357		65006190	p. 389			65101035	p. 410
	64230008	p. 358		65006200	p. 246			65101036	p. 414
	64230009	p. 359	<b>65007</b>	65007005	p. 385			65101041	p. 408
	64230010	p. 360		65007010	p. 385			65101042	p. 409
	64230013	p. 361		65007015	p. 390			65101043	p. 411
	64230015	p. 362	<b>65011</b>	65011005	p. 232			65101045	p. 410
	64230018	p. 363		65011010	p. 232			65101100	p. 418
	64230020	p. 364		65011020	p. 233			65101105	p. 418
	64230024	p. 365	<b>65014</b>		p. 400			65101110	p. 418
	64230030	p. 366	<b>65015</b>		p. 401	<b>65200</b>			p. 422
	64230045	p. 367	<b>65022</b>		p. 386	<b>65201</b>			p. 420
	64230303	p. 368	<b>65023</b>		p. 386	<b>65203</b>			p. 423
	64230304	p. 370	<b>65024</b>		p. 387	<b>65208</b>			p. 424
	64230320	p. 373	<b>65026</b>		p. 387	<b>65210</b>			p. 426
	64230322	p. 374	<b>65031</b>		p. 402	<b>65216</b>			p. 429
	64230340	p. 372	<b>65032</b>		p. 404	<b>65300</b>			p. 422
	64230400	p. 433	<b>65033</b>		p. 406	<b>65301</b>	65301001	p. 421	
	64230500	p. 430	<b>65034</b>		p. 402		65301002	p. 421	
	64230510	p. 431	<b>65035</b>		p. 404		65301050	p. 428	
	64230515	p. 432	<b>65036</b>		p. 406		65301051	p. 428	
<b>64300</b>		p. 355	<b>65041</b>		p. 403	<b>65303</b>			p. 423
<b>64999</b>		p. 318	<b>65042</b>		p. 405	<b>65310</b>			p. 425
<b>65001</b>		p. 378	<b>65043</b>		p. 407	<b>65315</b>			p. 427
<b>65002</b>		p. 379	<b>65044</b>		p. 403	<b>65317</b>			p. 429
<b>65003</b>		p. 380	<b>65045</b>		p. 405	<b>65981</b>	65981001	p. 435	
<b>65004</b>		p. 381	<b>65046</b>		p. 407		65981002	p. 435	
<b>65005</b>		p. 381	<b>65051</b>		p. 416		65981005	p. 436	
<b>65006</b>	65006005	p. 384	<b>65052</b>		p. 416		65981006	p. 436	
	65006010	p. 384	<b>65053</b>		p. 417		65981010	p. 437	



# INDICE PER CODICE PROGRESSIVO

INDEX FOR PROGRESSIVE CODES  
INDEX POUR CODE PROGRESSIF  
ÍNDICE PARA CÓDIGO PROGRESIVO

	<b>65981011</b>	p. 437		<b>66001115</b>	p. 331		<b>66002300</b>	p. 68
	<b>65981015</b>	p. 438		<b>66001120</b>	p. 209		<b>66002304</b>	p. 68
	<b>65981016</b>	p. 438		<b>66001300</b>	p. 183		<b>66002305</b>	p. 68
	<b>65981020</b>	p. 439		<b>66001305</b>	p. 61		<b>66002309</b>	p. 68
	<b>65981021</b>	p. 439		<b>66001310</b>	p. 74		<b>66002310</b>	p. 68
	<b>65981025</b>	p. 440		<b>66001315</b>	p. 86		<b>66002314</b>	p. 68
	<b>65981030</b>	p. 441		<b>66001320</b>	p. 98		<b>66002350</b>	p. 80
<b>65991</b>	<b>65991001</b>	p. 443		<b>66001325</b>	p. 110		<b>66002354</b>	p. 80
	<b>65991003</b>	p. 443		<b>66001335</b>	p. 121		<b>66002355</b>	p. 80
	<b>65991005</b>	p. 444		<b>66001340</b>	p. 36		<b>66002359</b>	p. 80
	<b>65991010</b>	p. 447		<b>66001345</b>	p. 48		<b>66002360</b>	p. 80
	<b>65991015</b>	p. 447		<b>66001500</b>	p. 186		<b>66002364</b>	p. 80
	<b>65991020</b>	p. 444		<b>66001501</b>	p. 187		<b>66002380</b>	p. 92
	<b>65991021</b>	p. 445		<b>66001505</b>	p. 62		<b>66002384</b>	p. 92
	<b>65991025</b>	p. 445		<b>66001510</b>	p. 75		<b>66002385</b>	p. 92
	<b>65991030</b>	p. 446		<b>66001515</b>	p. 87		<b>66002389</b>	p. 92
	<b>65991040</b>	p. 446		<b>66001520</b>	p. 111		<b>66002390</b>	p. 92
	<b>65991100</b>	p. 448		<b>66001525</b>	p. 99		<b>66002394</b>	p. 92
	<b>65991110</b>	p. 449		<b>66001530</b>	p. 122		<b>66002400</b>	p. 117
<b>65999</b>	<b>65999001</b>	p. 379		<b>66001535</b>	p. 49		<b>66002404</b>	p. 117
	<b>65999002</b>	p. 327	<b>66002</b>	<b>66002105</b>	p. 168		<b>66002405</b>	p. 117
<b>66001</b>	<b>66001020</b>	p. 185		<b>66002108</b>	p. 169		<b>66002409</b>	p. 117
	<b>66001025</b>	p. 185		<b>66002110</b>	p. 104		<b>66002410</b>	p. 117
	<b>66001030</b>	p. 185		<b>66002113</b>	p. 104		<b>66002414</b>	p. 117
	<b>66001035</b>	p. 185		<b>66002115</b>	p. 168		<b>66002430</b>	p. 42
	<b>66001040</b>	p. 185		<b>66002118</b>	p. 169		<b>66002434</b>	p. 42
	<b>66001045</b>	p. 185		<b>66002120</b>	p. 104		<b>66002435</b>	p. 42
	<b>66001050</b>	p. 109		<b>66002124</b>	p. 104		<b>66002439</b>	p. 42
	<b>66001051</b>	p. 109		<b>66002125</b>	p. 168		<b>66002440</b>	p. 42
	<b>66001055</b>	p. 60		<b>66002129</b>	p. 169		<b>66002444</b>	p. 42
	<b>66001056</b>	p. 60		<b>66002130</b>	p. 104		<b>66002445</b>	p. 34
	<b>66001060</b>	p. 73		<b>66002134</b>	p. 104		<b>66002449</b>	p. 34
	<b>66001061</b>	p. 73		<b>66002150</b>	p. 168		<b>66002450</b>	p. 34
	<b>66001065</b>	p. 85		<b>66002155</b>	p. 168		<b>66002454</b>	p. 34
	<b>66001066</b>	p. 85		<b>66002160</b>	p. 168	<b>66005</b>	<b>66005105</b>	p. 170
	<b>66001070</b>	p. 97		<b>66002165</b>	p. 168		<b>66005109</b>	p. 171
	<b>66001071</b>	p. 97		<b>66002170</b>	p. 168		<b>66005110</b>	p. 106
	<b>66001075</b>	p. 120		<b>66002200</b>	p. 56		<b>66005114</b>	p. 106
	<b>66001076</b>	p. 120		<b>66002204</b>	p. 56		<b>66005115</b>	p. 170
	<b>66001080</b>	p. 35		<b>66002215</b>	p. 56		<b>66005119</b>	p. 171
	<b>66001085</b>	p. 47		<b>66002219</b>	p. 56		<b>66005120</b>	p. 106
	<b>66001105</b>	p. 195		<b>66002225</b>	p. 56		<b>66005124</b>	p. 106
	<b>66001110</b>	p. 322		<b>66002229</b>	p. 56		<b>66005125</b>	p. 170

66005129	p. 171		66005435	p. 44		66009009	p. 175
66005130	p. 106		66005439	p. 44		66009015	p. 176
66005134	p. 106		66005440	p. 44		66009019	p. 176
66005150	p. 170		66005444	p. 44		<b>66010</b> 66010005	p. 178
66005154	p. 171	<b>66006</b>	66006006	p. 174		66010010	p. 108
66005155	p. 170		66006020	p. 172		66010030	p. 72
66005160	p. 170		66006024	p. 173		66010035	p. 84
66005165	p. 170		66006030	p. 45		66010040	p. 96
66005170	p. 170		66006034	p. 45		66010045	p. 119
66005200	p. 58		66006040	p. 107		66010050	p. 178
66005204	p. 59		66006044	p. 107	<b>66012</b>		p. 177
66005205	p. 58		66006050	p. 172	<b>66013</b>		p. 242-243
66005209	p. 59		66006054	p. 173	<b>66014</b> 66014004		p. 179
66005210	p. 58		66006055	p. 172		66014006	p. 180
66005214	p. 59		66006059	p. 173		66014010	p. 181
66005215	p. 58		66006060	p. 172		66014015	p. 182
66005219	p. 59		66006064	p. 173	<b>66015</b> 66015001		p. 251
66005300	p. 70		66006305	p. 71		66015010	p. 252
66005304	p. 70		66006309	p. 71		66015011	p. 253
66005305	p. 70		66006310	p. 83	<b>66031</b>		p. 208
66005309	p. 70		66006314	p. 83	<b>66036</b>		p. 335
66005310	p. 70		66006320	p. 95	<b>66037</b>		p. 233
66005314	p. 70		66006324	p. 95			
66005350	p. 82		66006500	p. 174			
66005354	p. 82		66006505	p. 72			
66005355	p. 82		66006510	p. 84			
66005359	p. 82		66006515	p. 96			
66005360	p. 82		66006520	p. 108			
66005364	p. 82		66006525	p. 119			
66005380	p. 94		66006530	p. 46			
66005384	p. 94	<b>66007</b>	66007100	p. 169			
66005385	p. 94		66007105	p. 169			
66005389	p. 94		66007150	p. 105			
66005390	p. 94		66007200	p. 57			
66005394	p. 94		66007205	p. 57			
66005400	p. 118		66007300	p. 69			
66005404	p. 118		66007305	p. 69			
66005405	p. 118		66007350	p. 81			
66005409	p. 118		66007355	p. 81			
66005410	p. 118		66007385	p. 93			
66005414	p. 118		66007430	p. 43			
66005430	p. 44		66007435	p. 43			
66005434	p. 44	<b>66009</b>	66009005	p. 175			











# CONDIZIONI DI VENDITA

GENERAL SALES CONDITIONS  
CONDITIONS GENERAL DE VENTE  
CONDICIONES GENERALES DE VENTA

Le condizioni di seguito riportate si intendono accettate dal committente in fase di ordinazione.

**1. ORDINI:** con il conferimento dell'ordine si intendono approvate dal committente tutte le condizioni di vendita in vigore, salvo accordi particolari accettati dai contraenti. Tutti gli ordini sono irrevocabili da parte del committente ma potranno non essere da noi evasi a nostro insindacabile giudizio e senza obbligo di comunicazione o giustificazione. Nell'ordine è necessario specificare il codice dell'articolo.

**2. PREZZI:** i prezzi si intendono per merce franco nostro magazzino (imballo, iva, trasporto esclusi) e non sono impegnativi. I prezzi che avranno valore saranno quelli in vigore al momento della spedizione.

**3. IMBALLO:** gratuito, salvo specifiche richieste del committente, che verranno fatturate al costo.

**4. SPEDIZIONE:** verrà effettuata come segue:

a) a mezzo nostro corriere di fiducia, in porto franco con addebito in fattura, in tal caso la merce sarà parzialmente assicurata\*\* (vedere punto 10 dell'elenco);

b) a corriere di fiducia del committente: la resa sarà franco nostro stabilimento di Monticello e la merce viaggia a totale rischio e pericolo del committente. Pertanto in caso di ritardi, ammanchi, avaria, furti, etc. i reclami devono essere indirizzati al Vettore, solo ed unico responsabile.

**5. CONSEGNE:** il termine di consegna, qualora venisse indicato, è puramente indicativo e pertanto solleva la nostra società da ogni qualsivoglia rivalsa.

**6. RECLAMI:** debbono pervenire per iscritto entro 8 giorni dalla data di ricevimento merce. Trascorso tale termine, i reclami non verranno accettati. I reclami di qualsiasi natura non sospendono l'obbligo di effettuare i pagamenti nella forma convenuta. L'acquirente, nel caso che la merce sia da noi ritenuta non idonea, ha diritto esclusivamente alla sostituzione della stessa o all'accredito dell'importo. Ogni altro tipo di indennizzo si intende privo di valore. Per qualsiasi contestazione si elegge unico foro competente quello del Tribunale di Lecco.

**7. RESI:** ogni reso o sostituzione dovrà essere preventivamente autorizzato da KRINO SPA. La merce sarà accettata di ritorno, salvo verifica all'arrivo in magazzino. Questa dovrà essere inviata in porto franco e accompagnata dalla bolla di consegna con indicati gli estremi della fattura con la quale è stata precedentemente fornita.

**8. PAGAMENTI:** debbono essere effettuati esclusivamente alla nostra sede, secondo le forme concordate. Nel caso di ritardato pagamento, verranno addebitati gli interessi bancari dalla data di scadenza concordata sino all'avvenuto pagamento, maggiorati delle eventuali spese accessorie.

**9. CARATTERISTICHE DEI PRODOTTI:** le immagini contenute nel presente catalogo sono puramente indicative, pertanto la nostra azienda si riserva il diritto di apportare modifiche migliorative dei prodotti senza nessun obbligo di preavviso.

**LA RIPRODUZIONE ANCHE PARZIALE DEL PRESENTE CATALOGO È VIETATA**

**10. VALORE DELL'ORDINE:** la spedizione verrà effettuata come segue:

- ordini singoli (non cumulabili) di importo superiore a Euro 600,00: spedizione in porto franco a mezzo nostro corriere di fiducia;

- ordini singoli (non cumulabili) di importo inferiore ad Euro 600,00: spedizione in porto franco con addebito in fattura di Euro 10,00;

- ordini singoli (non cumulabili) di importo inferiore ad Euro 100,00: spedizione in porto franco con addebito in fattura di Euro 10,00 + addebito di € 10 per oneri gestionali.

Riepilogando:

Valore ordine	Trasporto / Addebito	Oneri gestionali
Maggiore di Euro 600,00	Porto Franco	-
Minore di Euro 600,00	Euro 10,00	-
Minore di Euro 100,00	Euro 10,00	Euro 10,00

1. **ORDERS:** when an order is placed, all conditions are automatically accepted by the client. The order is irrevocable but we reserve the right to accept it. All orders should specify the items numbers.

2. **PRICES:** all prices are ex works (packing, VAT and freight excluded).

3. **PACKAGING:** is free, a part of special requirements extra charged.

4. **SHIPMENT:** It can be CIF with invoice charge, by parcel post or with a forwarding agent suggested by the customer.

5. **DELIVERY TIME:** is purely indicative.

6. **CLAIMS:** They should be notified within 8 days from the date of goods receipt. We shall only arrange free replacement of the tools acknowledged as defective ones by us. In case of dispute, the Civil Court of LECCO will be competent.

7. **GOODS RETURNED:** Any goods return should be authorized by us.

8. **PAYMENTS:** to be made directly to our head office. In case of late payment, we charge the bank interest rate, including additional expenses.

9. **PRODUCTS CHARACTERISTICS:** The images of this catalogue are purely indicatives, we reserve the right to make modifications without any notice.

**THE REPRODUCTION OF THIS CATALOGUE IS PROHIBITED.**

Any clause contained into your order sheets which is in contrast with the above mentioned conditions it is not valid.

1. **COMMANDES:** Chaque commande envoyée accepte automatiquement nos conditions de vente. Les commandes sont irrévocables mais nous nous réservons le droit de les accepter. Dans les commandes signalez les codes des références.

2. **PRIX:** Les prix sont pour marchandise franco départ (emballage, VAT et transport exclus).

3. **EMBALLAGE:** gratuit, sauf spécifique demande du client et qui sera chargée sur la facture.

4. **EXPEDITION:** CIF avec charge sur facture, par plis postal ou par le transporteur du client.

5. **DELAI DE LIVRAISON:** Le délai est seulement indicatif.

6. **RECLAMATIONS:** Ils doivent être notifiés par écrit dans 8 jours de la date de réception de la marchandise. Ils seront pris en considération si les outils seront reconnues pour nous défectueux. Le Tribunal de LECCO sera compétent en cas de n'importe quelle contestation.

7. **MERCHANDISE RENDUE:** Chaque envoi doit être autorisé par nous.

8. **PAIEMENTS:** devront parvenir exclusivement à notre siège en respect des accords pris. En cas de retards nous débiteurons les intérêts de banque et tous les frais accessoires.

9. **CARACTERISTIQUES DES PRODUITS:** Les images contenues dans ce catalogue là sont indicatives. Notre société se réserve le droit d'apporter des modifications aux produits sans aucune notification.

**LA REPRODUCTION DE CE CATALOGUE C'EST INTERDIT.**

N'importe quelle clause contenue dans Vos commandes et en contradictions avec les conditions ci-dessus n'est pas valable.

1. **PEDIDOS:** con el envío del pedido el cliente acepta automáticamente todas las condiciones de venta.

2. **PRECIOS:** Los precios son porte debidos (embalajes, IVA y transporte excluidos)

3. **EMBALAJE:** gratuito, salvo embalaje especial cargado en factura.

4. **PORTES:** Pagado con cargo en factura, paquete postal, con transportista del cliente.

5. **PLAZO DE ENTREGA:** aproximado

6. **RECLAMACIONES:** Se atenderán todas aquellas reclamaciones que se planten dentro del plazo de los 8 días siguientes a la recepción del material y comunicados sus discrepancias. En caso de litigio el fuero competente es el Tribunal de Lecco.

7. **DEVOLUCIONES DE MATERIAL:** Es obligatoria autorización de la Empresa para devolución del material.

8. **PAGO:** El pago debe ser enviado directamente a nuestra casa central.

9. **CARACTERISTICAS DE LOS PRODUCTOS:** Las imagines de este catalogo son indicativas. Nos reservamos el derecho de modificar cualquier articulo sin previo aviso.

**LA REPRODUCCION DE ESTE CATALOGO ES PROHIBIDA.**

Las clausolas contenidas en sus pedidos y en contra de nuestras condiciones no seran aceptadas.